

Interior Design using Augmented Reality

Nimesh More¹, Namrata Chavan², Humera Shaikh³, Prof. Sonali Karthik⁴

¹⁻³Student, Dept. of Information Technology Engineering, Theem College, India

⁴Professor, Dept. of Information Technology Engineering, Theem College, India

Abstract: AR technology is often used in applications that simulate an arrangement of furniture. We here will discuss a system supported Augmented Reality for Home Decoration, which supports real-time tracking without Identification Markers, the system uses FAST corner detection. To solve this problem, this paper proposes a method that can add virtual objects to the real environment (Augmented Reality) using a camera. Augmented Reality furniture arrangement systems are useful for viewing furniture in rooms or building layouts without having to buy or move real furniture in. However, such systems often require users to physically and regularly change their viewpoint of the physical space, which needs manual manipulation of the scene, and are often limited to 3D tablet or phone interfaces. To help address this problem, we have developed a system that automatically calculates the most suitable viewpoint to improve understanding of the room layout as a whole, and allows the user to easily transition to that viewpoint.

Key Words: - Augmented Reality, Software Development Kit, Interior Design,

I. INTRODUCTION

Recently augmented reality (AR) Sofa, paintings, flowerpot, chair, table arrangement systems help users overlay virtual furniture onto the important world. Such systems allow people to ascertain how the space will look with new furniture without actually buying or moving real furniture. Augmented Reality (AR) may be a quiet Computer Vision Technology which may add the virtual information to the real environment, which makes the virtual and therefore the real as an entire. It's a well-liked research area. In recent years, more and more researchers studied there. The research is especially divided into two directions: within the aspect of theory, the student innovated constantly on the key algorithms of the core part, from supported the synthetic markers to the natural markers, and then supported the visual no marker system, they made the Augmented Reality Technique's implementation more and more natural; On the opposite hand, in business applications, they created the increased Reality Technique's implementation a lot of and a lot of natural; On the alternative hand, in business applications. We will combine the idea and business application, applying the Augmented Reality Technique to the household decoration. The research supported the Virtual Home Augmented Reality System of Android OS, consists of the researches and therefore the developments for the key algorithms of each module of the system. The system can stack the virtual 3D furniture models on the user's real room, place the furniture through human computer interaction, simulate the home decoration process, create home space in dream, make selecting furniture and therefore the decoration more convenient, which has commercial value. This technique supports real-time tracing with Identification markers.

II. SYSTEM ANALYSIS

This system is a interior design developed by AR Foundation Framework SDK Augmented Reality technique based on Unity platform for android/IOS devices, it can realistically display the virtual models on the user's real scene and also takes and showing the measurements of the Augmented Components, realizing the user's operation to home and the real-time photo to AR scene.

A. System General Design

The system uses a mobile built-in camera to gather images because the real scene image is observed by the human eye and stacks the 3D furniture models on the screen display image. First of all, we'd like to try to do the feature detection description to the pictures collected by the camera, choose tracing images and do 3D registration, establish initial 3D map and acquire the camera pose. Next, we build 3D furniture models by using unity3d. Through identifying and tracing marker images, the camera obtains external parameters matrix and establishes projection models, eventually stacks the imported 3D virtual models on the tracing image. Because Android smartphones have touch-screen interface function, we will place the furniture by sliding screen. The system framework of this is as shown in Figure 1

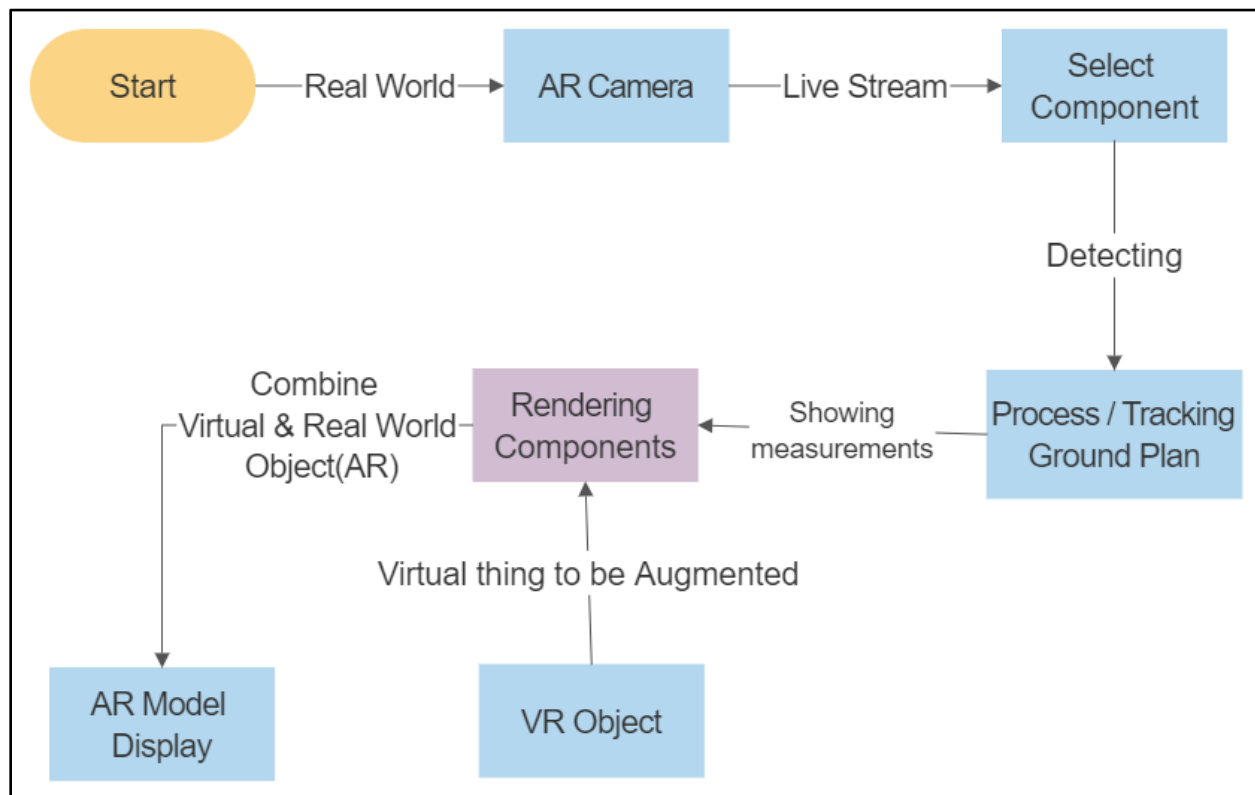

Fig 1 : System framework figure

B. Analysis and Design of Tracking Module

As the start of the entire AR scene, tracking mode plays an important role within the entire display module. This Augmented Reality system we hope to determine only needs the user to interact with the mobile with none other auxiliary operations, which may experience the virtual interior augmented reality in any unknown indoor scene. Initially the environment is made using the Ar Foundation framework Sdk. That's the augmented reality camera which will display the 3d models in the Real world processing and tracking the ground plane surface. a picture which will be easily found by any user is going to be set as augmented in the real world and the user can feel it as real.

C. Analysis and Design of Exhibition Module

The exhibition effects this technique wants to understand is that stacking the virtual Component on the selected portion of the room, and may place and observe the virtual Model in real time. The display module contains the development of 3D models, the making of 3D display animation and therefore the establishment of the virtual components projection models, which may make it stack on the important environment. After initializing the system, we will determine the projection model from the important scene to the camera at the specified location or area. consistent with the Rendering model, it then uses AR camera to locate the position and place the virtual models real-time display on the live feed camera

D. Screen Interactive Module

This Application is user interactive and designed for experiencing real world view. User can also set the 3d components as per he want to place it user can also get the measurements of the 3d display components in Ar camera he can zoomIn and zoomOut it as per he want to set the room, also user can see all the components at one time he can see all the designing view in real world using this application.

III. Design and Development:

This system functions with 4 different modules, They are

- 1.Live Stream
- 2.Detection
- 3.Measurement
4. Combine virtual and real world object

1.Live stream:-

The biggest benefit of the live stream is, it saves the time of the users.

It will help the user to move the object in the 360 view.

When the user opens the application, the camera will be started. The user will place that camera where the user wants to place that selected component.

2. Detection:-

When the user places the camera at a particular place and selects one of the components it will detect it and place the selected object.

when the object has been placed the user can rotate the object as per the choice.

The camera will detect the ground plan and place the selected object at the particular place.

3. Measurement:-

When the user places the camera at a particular place and selects one of the components it will detect it and place the selected object.

And before it's placed the user has to enter the length and breadth of the selected object.

It will show that how much area is covered by the component and it is much helpful for designing the interior of a room

4. Combine virtual and real world object:-

When a user places all the objects at their particular place, after all that user can see those components at a time. As it will look like a living room. And if a user wants to replace the object then He/She can change it.

It will give a complete look to an empty room.

IV. USE-CASE DIAGRAM:

A use case diagram at its simplest may be a representation of a user's interaction with the system that shows the connection between the user and therefore the different use cases during which the user is involved. A use case diagram can identify the various Otypes of users of a system and therefore the different use cases and can often be amid other sorts of diagrams also. The use cases area represented and unit painted by either circles or ellipses.

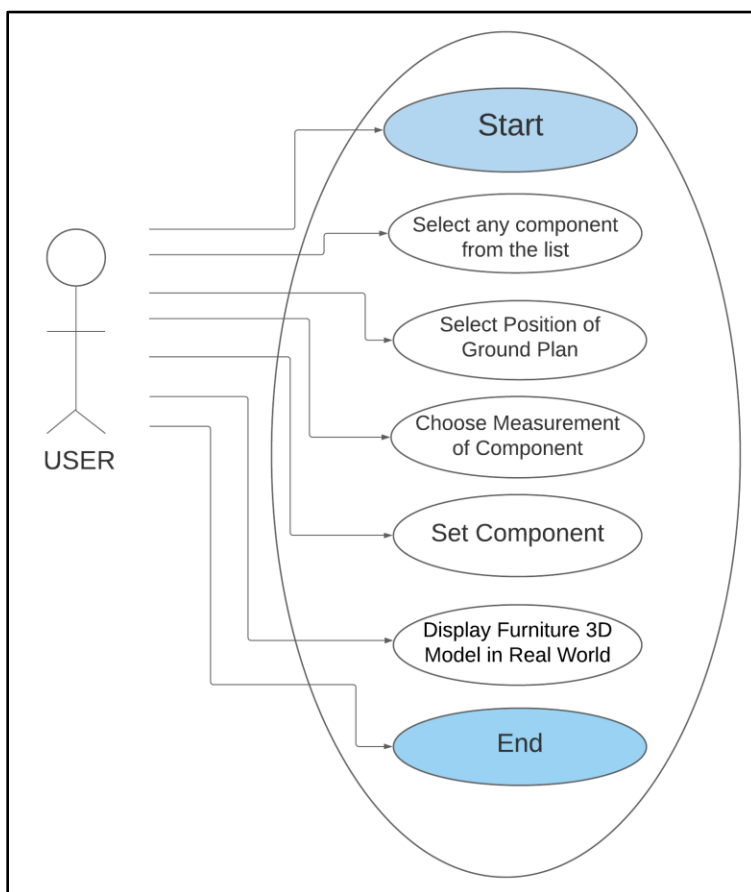
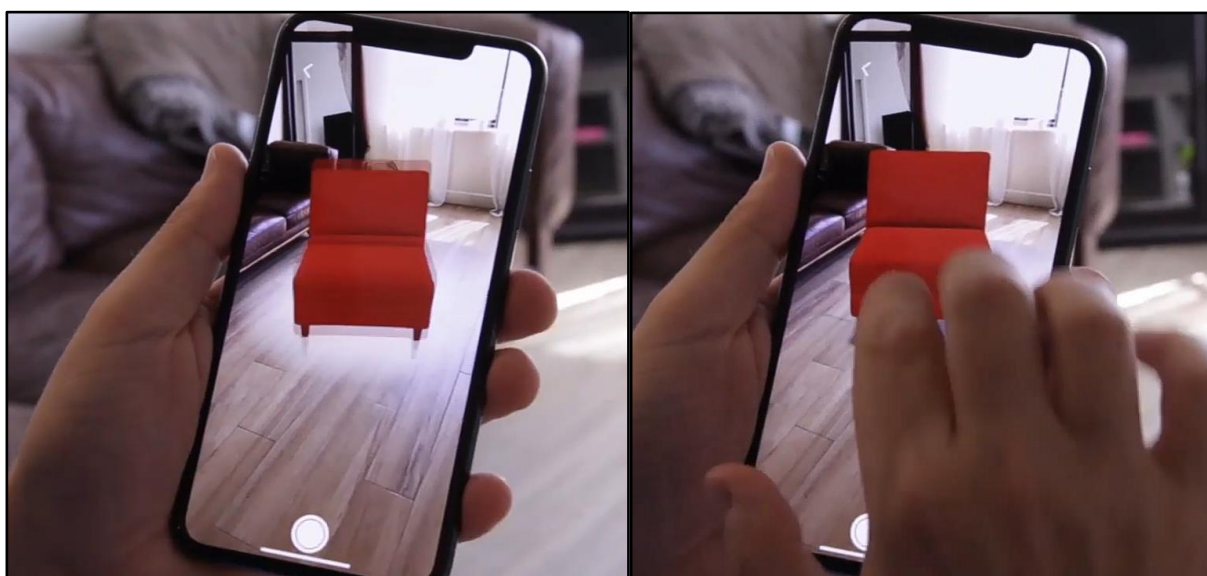

Fig 2.: Use Case diagram of Interior designing and Planning using augmented reality

V. EXPERIMENTAL RESULTS:



(3)

(4)

Fig(3): Object is Rendered using AR interior design interface.

Fig(4): Display Of 3D Model using AR interior design interface.

VI. Literature Review:

Augmented reality helps the user to see environment and products. It can help in the making and testing of any category of product design to be tested, or to enable the user to participate in certain categories of product health, such as assisting in the decision process during the purchase step.

In other words, the unpopularity of tax collectors we see is true considered a custom application inside your tablet or almost identical phone a live view of the physical world.

VII. Conclusions:

Interior designing Application using Augmented Reality technology started to develop the real estate industry.

According to the survey the interior designer used to follow this trend and use the benefits of Augmented reality to make their work more easy and efficient.

This is the simplest way for a home tour.

AR technologies help us to understand or handle the vast information flow.

This application provides the customer perspective by showing the needy objects of the room.

If the customer wants to know how his/her future room looks alike they can view through this application.

As it is very beneficial for the interior designer to show the designs earlier and can make the changes before the work starts.

VIII. References:

- [1] Approach to the Interior Design Using Augmented Reality Technology Jiang Hui 2015 Sixth International Conference on Intelligent Systems Design and Engineering Applications (ISDEA)
- [2] The Design and Realization of Real-Time Texture Mapping /Collage in Virtual Home Decoration Xixi Huang; Mingmin Zhang; Ling Lin; Zhigeng Pan; Rongzhao Li 2012 Fourth International Conference on Digital Home
- [3] Research on the augmented reality system without identification markers for home exhibition Liyan Chen; XiaoyuanPeng; Junfeng Yao; Hong Qiguan; Chen; Yihan Ma 2016 11th International Conference on Computer Science & Education (ICCSE)
- [4] A Transitional AR Furniture Arrangement System with Automatic View Recommendation Mami Mori; Jason Orlosky; Kiyoshi Kiyokawa; HaruoTakemura 2016 IEEE Interna
- [5] AR interior designer: Automatic furniture arrangement using spatial and functional relationships Jeff K. T. Tang; WanMan Lau; Kwun-Kit Chan; Kwok-Ho To 2014 International Conference on Virtual Systems & Multimedia (VSMM)