

LORA Based Women Safety System Using IoT

Mr. KALAIMAAMANI.K^[1], ARTHI.S^[2], DIVYA.M^[3], DIVYA.S^[4]

Professor^[1], Dept. of Electronics and Communications Engineering, Mahendra Engineering College, Namakkal, Tamil Nadu, India.

Student^[2,3,4], Dept. of Electronics and Communications Engineering, Mahendra Engineering College, Namakkal, Tamil Nadu, India.

Abstract - Women security is fundamental now-a-days. In India, there are numerous instances of Women badgering and attack expanding day by day. Wellbeing of Women matters let be whether at home, open air or it be their work place. The writing studied shows that there are numerous portable applications that are utilized for Women wellbeing reason. We center around building up a model that is a keen band which gets initiated by tapping on the screen twice. When the gadget is initiated, it begins sending live information area constantly to the specific individual contacts and police control rooms utilizing GPS recipient and LORA. At the point when the catch is squeezed then the ringer caution framework begins to actuate. Simultaneously sends warning to that specific individual cell phone utilizing IOT innovation. A Piezo signal alarm will get actuated, when the gadget getting turned on. The scope of the signal is of 80-110 dB which can be heard from a distance of 50 feet in length. Our proposed framework utilizes a NodeMCU to identify Women wellbeing and sends the outcomes by means of Wifi utilizing Internet of Things.

Key Words: Node MCU, IOT, framework.

I. INTRODUCTION

Internet of things (IoT) is impacted with human existence in both intentionally just as unwittingly. With an assistance of web each machine is controlled, which makes individuals life simpler. These days young Women were not allowed to move openly in the roads where they mishandled by outsiders. Guardians are troubling about their wellbeing which has become the primary obstruction to send their girls outside. Bit by bit the Women provocation have been rises. Security is the most required force for everyone in this day

and age in current age. In our Country, despite the fact that there is a financial turn of events, yet at the same time there are numerous violations occurs against Women. In everyday 86% of working women in India, confronting an obstruction which is more prominent in Delhi, Mumbai, Hyderabad, Kolkata, Chennai and Pune, relatively to different spots. Innovation is the best method to accomplish their security. With the assistance of IOT we can handle and access the machines and things which are associated with the web even the distances are excessively long. Without the human-human and PC human collaboration, we can send and get data. Be that as it may, the provocations, assault, corrosive assault are not decreased still. To make them protected, a shrewd gadget are created. Women wellbeing gadget is uniquely intended for Women in the event of hazardous and crisis circumstance. The Women wellbeing gadgets ought to be basic, simple to convey and that ought to be incorporated with a few functionalities. The advanced mobile phones utilization has been definitely expanded on the planet. There are a few portable applications and brilliant gadgets are created by the public authority and individuals to help the Women when they are in the difficulty. Despite the fact that, they created different gadgets and applications the pace of the sexual offenses has not been diminished. The Women security gadgets or application ought to be joined with a few highlights which are utilized in day today life and genuine crisis cases.

II. EXISTING SYSTEM

Numerous applications, for example, portable applications like "HELP ME ON MOBILE" is created. In the event that

there is any crisis to that code Women either call or send message.

III. PROPOSED SYSTEM

The gadget speaks with advanced cell through an exceptionally planned application that acts an interface between the gadget and the telephone. The information of brilliant gadget is consistently observed by the application which is pre-introduced in the telephone. In instances of misuse, the application guides the PDA to play out the accompanying errands such as Sends message to the relatives. It likewise ships off closest police headquarters mentioning prompt activity. The application is customized so that it utilizes the GPS of the advanced cell to follow the coordinates and screen the development for simple track capacity.

3.1 ADVANTAGES

This gadget can be conveyed wherever since it is little and furthermore gives wellbeing to Women. This will manage basic issues looked by Women during the evening and give security cutting edge innovation.

IV. RELATED WORK

4.1 ESP8266 NodeMCU

NodeMCU is an open-source firmware and improvement pack that assists you with displaying or manufacture IoT things. The firmware uses the Lua coordinating language. It relies upon the eLua project and dependent on the Espressif Non-OS SDK for ESP8266. With its USB-TTL, the hub MCU Dev board maintains clearly bursting from USB port.

4.2 Button

A Button is utilized to convey a crisis message to the police or close by individuals in a crisis circumstance like heart failure or any genuine medical problem where pressing assistance is required or the circumstance where you are

assaulted by somebody or criminals break into house and so forth In India, government made it compulsory to have signal for an emergency response in cell phone, which when squeezed, will call the police with the current area of the individual in harm's way. So here in this undertaking we will make an actual catch utilizing ESP8266 Wi-Fi module which will send a ready notice to predefined portable number when squeezed.

4.3 Vibration

The vibration sensor is additionally called a piezoelectric sensor. These sensors are adaptable gadgets which are utilized for estimating different cycles. This sensor utilizes the piezoelectric impacts while estimating the progressions inside speed increase, pressure, temperature, power in any case strain by changing to an electrical charge. This sensor is additionally utilized for choosing scents inside the air by promptly estimating capacitance just as quality. The working rule of vibration sensor is a sensor which works dependent on various optical in any case mechanical standards for identifying noticed framework vibrations. The affectability of these sensors regularly goes from 10 mV/g to 100 mV/g, and there are lower and higher sensitivities are additionally open. The affectability of the sensor can be chosen dependent on the application. So it is vital for now the degrees of vibration adequacy reach to which the sensor will be uncovered all through estimations.

4.4 Buzzer

A chime or beeper is a sound hailing contraption, which may be mechanical, electromechanical, or piezoelectric (piezo for short). Ordinary livelihoods of signs and beepers consolidate ready devices, timekeepers, and confirmation of customer data, for instance, a mouse snap or keystroke.

4.5 LORA

This is a norm and crisis Switch. This button is incredible for client input. On the off chance that the casualty is at serious risk, by squeezing the switch the gets initiated alongside

ringer. So squeezing the catch, LORA can send the crisis circumstance without Mobile administrations of sender.

V. SYSTEM ARCHITECTURE

Transmitter

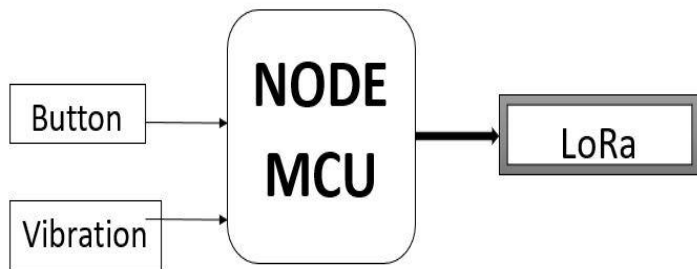

Receiver

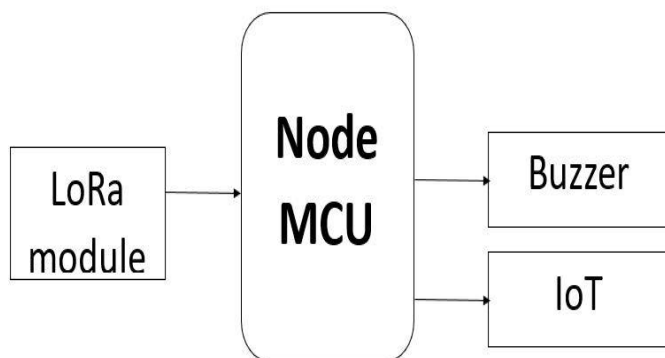

VII. CONCLUSIONS

Being free from any and all harm is the interest of the day. Our work behind this undertaking is to plan a one framework which is so smaller in itself that give benefit of individual security framework. This plan will manage the greater part of the basic issues looked by Women and will assist them with being secure. The proposed instrument gives seeing the area of the casualty regarding scope and longitude which can additionally be followed. This framework assists with diminishing the crime percentage against Women. Women' security is a basic issue in current

circumstance. The paper primarily centers around the ease execution of the gadget which can save the existence of the Women in the basic condition the proposed framework gives start to finish security answers for Women wellbeing utilizing the development advances of IoT. This sort of a thought being the first of its sort assumes a significant part towards guaranteeing Women Safety in the quickest manner conceivable consequently. The proposed configuration will manage basic issues looked by Women in the new past and will help settle them through innovatively solid contraptions. The framework can play out the continuous observing of wanted territory and recognize the savagery with a decent precision. Accordingly, the framework when an individual press a catch then the notice will ship off a specific individual and a ringer framework is actuated. The GPS recipient consistently screens the area of that Women. The warning and area subtleties is send to that Women' family by means of NodeMCU WiFi utilizing an IOT innovation.

REFERENCES

- 1.Nandita Viswanath, Naga Vaishnavi Pakyala, Dr. G. Muneeswari, "Smart Foot Device for Women Safety" IEEE Conference, ISBN:978-1-5090-0931-2, 2016.
- 2.D. G. Monisha, M. Monisha, G. Pavithra and R. Subhashini "Women Safety Device and Application - FEMME" Indian Journal of Science and Technology, ISSN : 0974-5645, 2016.
- 3.Vallidevi Krishnamurthy, Saranya. S, Sharanya Srikanth, Simran Modi, "M-WPS: Mobile based Women Protection System" IEEE International Conference on Energy, Communication, Data Analytics and Soft Computing ISBN: 978-1-5386-1887-5, 2017.
- 4.Dantu Sai Prashanth, Gautam Patel, Dr.B.Bharathi "Research and development of a mobile based women safety application with realtime database and data-stream network" IEEE International Conference on circuits power

And computing technologies, ISBN 978-1- 5090-4967- 7, 2018.

5.Jismi Thomas, Maneesha K J, Nambissan Shruthi Vijayan, "TOUCH ME NOT-A Women Safety Device" International Research Journal of Engineering and Technology, ISSN: 2395-0056 Volume: 05, 2018.

6. Muskan, Teena Khandelwal, Manisha Khandelwal, Purnendu Shekhar Pandey "Women Safety Device Designed using IoT and Machine Learning" IEEE Smart World, Ubiquitous Intelligence & Computing, Advanced & Trusted Computing, Scalable Computing Communications, Cloud & Big Data Computing, Internet of People and Smart City Innovations, ISBN: M978-1-5386-9380-3, 2018.

7.Piyush Kumar Verma, Arpit Sharma, Dhruv Varshney, Manish Zadoo," Women Safety Device With GPS, GSM And Health Monitoring System" , International Research Journal of Engineering and Technology, ISSN:2395-0056,Volume:05,2018.

8.Kalpna seelam, K.Prasanti," A Novel Approach to Provide Protection for Women by using Smart Security Device" IEEE International Conference on Inventive Systems and Control, ISBN: 978-1-5386-0807-4, 2018.

9.Pragna B R, Poojary Praveen Mahabala, Punith N, Sai Pranav, Shankar Ram "Women Safety Devices and Applications" International Journal of Engineering Research and Technology Vol. 7 Issue 07, 2018

10.Sankalp Mehta, Sachin Janawade, Vinayak Kittur, Suraj Munnole,Sandhya Basannavar "An Android Based Application or Women Safety" International Journal of Engineering Science and Computing, 2017.