

Development of Economical Infrared Thermometer

Kanad Jaiswal¹, Sunny Sah¹, Ashutosh Kumar Happy¹

¹ Final Year Students of Dept. of EEE, MAIT (GGSIPU) NEW DELHI, INDIA

Abstract – An infrared in temperature test estimates temperature by recognizing the infrared energy transmitted by all materials which are at temperatures above outright zero, (0°Kelvin). The most essential plan comprises of a focal point to center the infrared (IR) energy on to a finder, which changes the energy over to an electrical sign that can be shown in units of temperature subsequent to being made up for surrounding temperature variety. This setup works with temperature estimation from a distance without contact with the item to be estimated. Thusly, the infrared temperature sensor is helpful for estimating temperature under conditions where thermocouples or other test type sensors can't be utilized or don't create exact information for an assortment of reasons. Some common conditions are the place where the item to be estimated is moving; where the article is encircled by an EM field, as in enlistment warming; where the item is contained in a vacuum or other controlled air; or in applications where a quick reaction is required

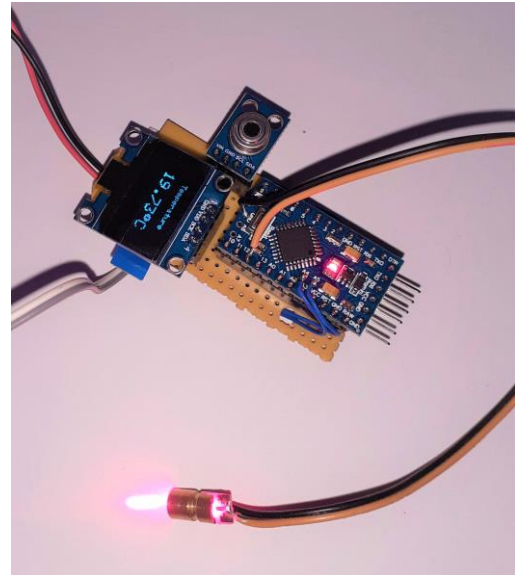

Fig -1: Infrared Thermometer

Key Words: Infrared temperature sensor; Thermometer, Arduino, Sensor

1.INTRODUCTION

Most of the temperature measurement techniques around the world require some sort of physical contact between the temperature sensor and the object or environment whose temperature is to be measured, but as technology advanced, this changed too. The need to be able to measure the temperature of an object without physical contact arose. This need brought the measurement of temperature using infrared sensors.

When debugging an electronics circuit or testing a new hardware design, often times we tend to check if the components on the board are getting hot abnormally by touching them. And if something is messed up components could get as hot as 80°C or more burning not only the component but also finger along with it.

We all are aware that the most powerful medium or say the reason for the spread of the COVID-19 virus is direct human-to-human contact. Infrared thermometers are non-contact thermometers that help you measure the temperature from the forehead without coming in contact with the skin.

1.1 THE SENSOR

The MLX 90614 thermometer sensor is plug and play gadget subsequently we can straightforwardly interface a ready gadget and effectively make warm alert gadget. The MLX90614 is an InfraRed thermometer for noncontact temperature estimations. Both the IR touchy thermopile locator chip and the sign molding ASSP are incorporated in something similar TO-39 can. On account of its low commotion speaker, 17-piece ADC and amazing DSP unit, a high precision and goal of the thermometer is accomplished.

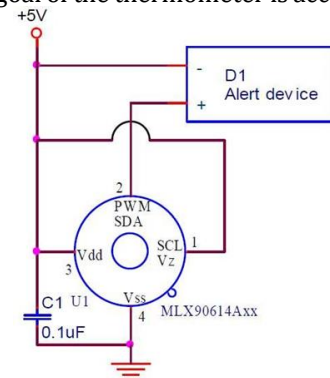

Fig -2: Thermal alert applications of MLX90614

The thermometer comes production line aligned with an advanced PWM and SMBus (Framework The board

Transport) yield. As a norm, the 10-cycle PWM is designed to consistently communicate the deliberate temperature in scope of - 20... 120°C, with a yield goal of 0.14°C. The manufacturing plant default POR setting is SMBus.

1.2 THE ARDUINO

This is a microcontroller board developed by Arduino.cc and relies on Atmega328. It carries out virtually same functions as different Arduino boards, however, it's completely different from Arduino Uno in terms of PCB layout, size, voltage regulation, and clock speed. The Arduino Uno comes with 2 transformer i.e. 5V and 3.3V whereas Arduino professional mini comes with just one transformer. There square measure 2 versions of Arduino professional mini square measure offered i.e. 5V and 3.3V that runs at 16MHz and thirty two megacycle severally



Fig -3: Arduino Mini Pro

1.3 DISPLAY

OLED is natural light transmitting diode that produces light because of an electric flow. OLED show works with no backdrop illumination so it can show profound dark levels. It is little in size and light in weight than Fluid Gem Showcases.



Fig -4: OLED SSD1306

128x64 OLED show is straightforward speck network realistic showcase. It has 128 sections and 64 columns which make it show of all out 128x64 = 8192 pixels. Simply by

turning on/off these pixel's driven we can show graphical picture of any shape on it.

2. WHY THIS PROJECT ?

In the midst of the rising instances of Covid in the country, we as a whole are embracing different measures to keep ourselves free from any and all harm like keeping up friendly separating, isolated at our homes, keeping ourselves and the encompassing clean, and so forth Among this, there are different fundamental items and gear needed to shield ourselves from the infection. These may incorporate ventilators, veils, sanitizers, PPE units, and so forth One such fundamental clinical gear assisting us with fighting this pandemic is Infrared thermometer. Lately, Infrared thermometers have demonstrated to be perhaps the most popular clinical gadgets.

3. THEORETICAL REALITIES WITH THERMAL TEMPERATURE MEASUREMENT

The recipes used to estimate infrared temperature are ancient, well-established, and welldocumented. While it is unlikely that any IRT clients would use the recipes, knowledge of them will pique interest in the interdependency of particular variables and help to clarify previous material. The below are the major equations:

1. Kirchoff's Law When an article is at warm harmony, the measure of assimilation will rise to the measure of emanation.
2. Stephan Boltzmann Law The more sweltering an item turns into the more infrared energy it radiates.
3. Wien's Removal Law The frequency at which the greatest measure of energy is discharged gets more limited as the temperature increments.
4. Planck's Condition Depicts the connection between unearthly emissivity, temperature and brilliant energy.

4. INFRARED THERMOMETER PLAN AND DEVELOPMENT

An essential infrared thermometer (IRT) plan, includes a focal point to gather the energy transmitted by the objective; an identifier to change the energy over to an electrical sign; an emissivity acclimation to coordinate with the IR in temperature test alignment to the radiating attributes of the article being estimated; and an encompassing temperature remuneration circuit to guarantee that temperature varieties inside the infrared temperature sensor, because of surrounding changes, are not moved to the last yield. For a long time, most of monetarily accessible IRT's followed this idea. They were amazingly restricted in application, and everything considered didn't gauge agreeably by and large, however they were truly strong and were satisfactory for the norms of the time.

The advanced IR temperature sensor is established on this idea, however is all the more innovatively modern to extend the extent of its application.

5. HARDWARE REQUIREMENTS

- Arduino Pro Mini
- MLX90614 Infrared Temperature Sensor
- OLED Display – SSD1306
- Laser Diode
- Power Supply/ 9v Battery
- Push button
- Connecting wires

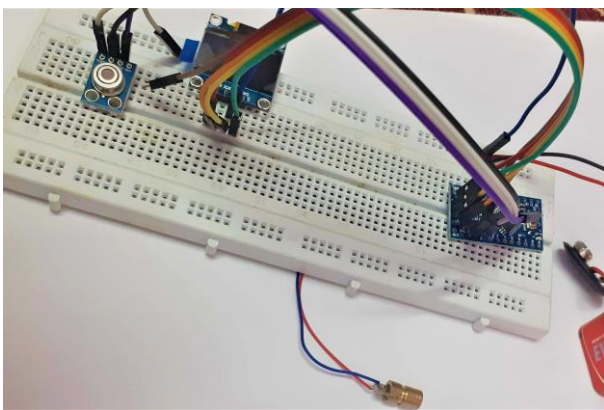

Fig -5: Testing of circuit on breadboard

6. HOW AN INFRARED THERMOMETER WORKS

Albeit not apparent to the natural eye, all items transmit infrared light beams and the focus fluctuates relying upon temperature. By distinguishing the IR beams, we can see the temperature range. The MLX90614 thermometer sensor works utilizing this guideline.

MLX90614 is an incredible infrared detecting gadget with an exceptionally low commotion speaker and a 17-piece ADC. It empowers high exactness and goal for the thermometer. The best part about the MLX90614 is it comes adjusted with a computerized SMBus from the manufacturing plant. This implies that it will give a yield with a high goal of 0.02°C and can constantly move the deliberate temperature in the scope of - 20 to 120°C.

Like noticeable light, infrared energy can be engaged, reflected and assimilated. Handheld IR thermometers utilize a focal point to center the infrared energy from an article onto a sensor that actions it, ordinarily a thermopile. The sensor ingests infrared radiation and converts it to an electrical sign, with more serious radiation making a more

grounded signal. The IR thermometer measures this sign to convey a temperature readout. Like noticeable light, it is additionally conceivable to center, reflect, or ingest infrared light. Infrared thermometers utilize a focal point to shine the infrared light producing from the article onto a finder known as a thermopile.

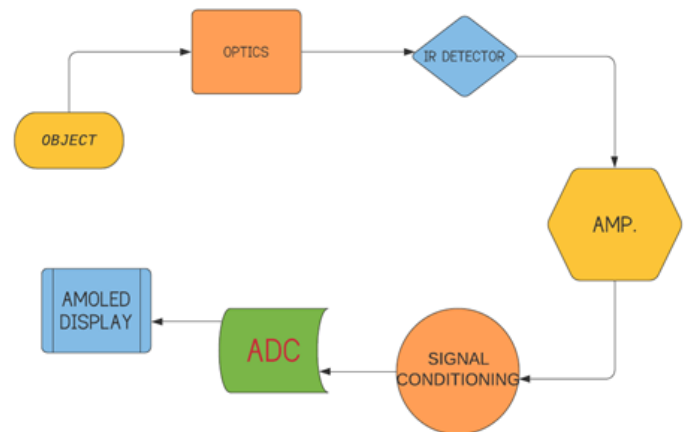

Fig -6: Block Diagram

The thermopile is only thermocouples associated in arrangement or equal. At the point when the infrared radiation falls on the thermopile surface, it gets retained and changes over into heat. Voltage yield is delivered in relation to the occurrence infrared energy. The identifier utilizes this yield to decide the temperature, which gets shown on the screen

7. CODE

The Program for Arduino should read the temperature value from the MLX90614 and display it on the OLED display. Adafruit has provided us a Library to easily read data from the MLX90614.

Like always we begin the program by adding the required library files. Here the Wire library (in-built) is used to communicate using I2C protocol and the SparkFunML90614 library is used to for communicating with the sensor. The SPI, GFX and SSD1306 libraries are used for communicating with 4-wire SPI protocol to the OLED display module.

```

#include <Adafruit_MLX90614.h>
#include <Adafruit_GFX.h>
#include <Adafruit_SSD1306.h>
  
```

We then define the pins of the OLED display to which we have made the connection. Since the module works with SPI we have used the SPI pins of the Arduino. There are OLED displays that works with I2C protocol as well, but we can't use them here since the I2C pins are already occupied by the thermometer sensor.

Here in India the most followed unit for temperature is Celsius (degree C) hence we have set the unit of the with TEMP_C we can also change this to TEMP_F if we need the values to be in Fahrenheit (F). Finally we initialize the OLED display and clear its display.

Inside the loop function, we read the value of temperature from the sensor and convert it into String to be displayed in the OLED display

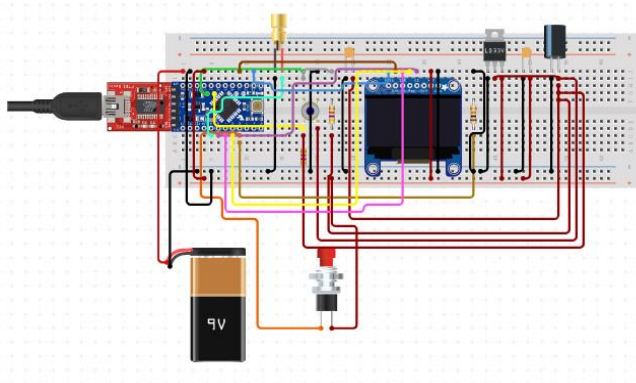

Fig -7: Circuit Diagram

8. FUTURE TRENDS IN THIS PROJECT

8.1 MINIMAL EFFORT AND SIMPLE TO ASSEMBLE – ANDROID APPLICATION FOR SALVAGE

On a brief glance, we can unmistakable a portion of the significant parts on a thermometer, in particular the IR temperature sensor, microcontroller, and the Battery. Presently our target here is to decrease the expense.

However as a creator, there are relatively few choices here that we can connect rapidly other than MLX90614 and MLX90614. Then again, in the event that you approve of utilizing a Simple sensor, you will have numerous less expensive other options however it will not be not difficult to fabricate and align your gadget, the decision is yours here. For this instructional exercise, we will utilize the MLX90614 sensor.

- using Proximity sensor, we automatically measure Temperature when object is near to the Device. We use this type of thermometer with automatic sanitization machine. So that it can measure temperature as well as sanitize people and Object.
- using wifi Module, we can share data with the website and android/iOS application.

- With using lithium polymer and lithium ion battery the duty cycle of device can be improved. The parallel charging technique of battery is used for the fast charging.
- Unique ID (UID) Management System is used to study the graph of Temperature rise and down of individual object. Cloud storage is used as well as solid state drive is used to store data for study.

With the sensor chose, we are just left with Microcontroller, Show, and Battery. So we chose to reduce down the expense of every one of these three sections by utilizing an Android Cell Phone. Today nearly everybody has a decent android telephone with a fair camera. We can make a basic Android application that can speak with our thermometer and perform different exercises like information logging and picture catch. This way we can make it work quicker as well as increment its likely application by momentarily sharing log results with pictures on WhatsApp, Gmail, or some other favored stage.

So the solitary material needed for this task is-

- MLX90614 IR Temperature Sensor
- TCRT5000 IR Sensor
- Arduino Nano
- Unique ID (UID) Management System
- The ESP8266WiFi Module
- Proximity sensor (PNP / NPN type)
- Lithium polymer/ ion battery
- Fast charging

8.2 WHY WE PICKED TCRT5000 AND ARDUINO NANO?

For some individuals, this inquiry would have sprung up. The justification utilizing a TCRT5000 IR sensor is to recognize the situation of the thermometer and take temperature perusing consequently. This way you could never need to do anything with the application whenever it is dispatched making it simple to utilize. Additionally, the perusing will be taken just when the sensor is in the correct

separation from the individual so we not stress over bogus readings.

The justification utilizing Arduino Nano is that it has an in-constructed USB interface which is essential to impart between the regulator and the telephone. On the off chance that you don't have one, you can likewise utilize the Mega or even the UNO. Yet, talking on cost terms, you can even utilize a much low force microcontroller like STM8S or whatever other regulator that upholds I2C, ADC, and UART will turn out great for this task.

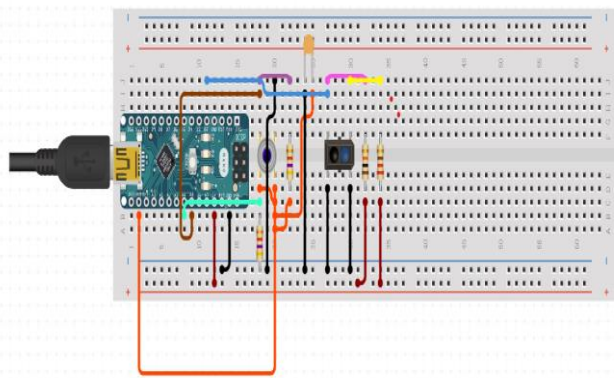

Fig -8: Circuit Diagram-II

The MLX90614 and TCRT500 work on 3.3V and 5V separately so we can control it appropriately. I2C correspondence pins A4 (SDA) and A5 (SCL) are utilized to speak with the MLX90614 sensor. It is entirely expected to utilize TCRT5000 with an Operation Amp in comparator mode as we did in our BLDC distant vehicle project however here we need it to be more solid and our IR sensor ought to be unsusceptible to daylight. So I have associated the IR diode to a computerized pin and the Photodiode to a Simple pin of the Arduino. This way we can gauge the worth from photodiode during the typical stage and afterward measure again in the wake of turning on the IR Drove, the contrast between these two qualities should help us manage clamor. More on this will be examined in the programming segment.

8.3 ARDUINO SOFTWARE FOR A CONTACTLESS SMART THERMOMETER

We start our program by adding the necessary header documents and pronouncing the factors. There are two significant factors here once is the error correction esteem

and other is the reach affectability esteem. Despite the fact that the MLX90614 is processing plant adjusted, I tracked down that the qualities were reasonable just in the event that I enhance it. For my situation, I needed to add 3.2 to the worth I acquired from the sensor to get dependable qualities. I tried my qualities against a handheld thermometer and tracked down that subsequent to adding this blunder rectification worth and discovered it to be solid. The following variable is the Reach affectability in the event that we decline this worth, we can expand the scope of our thermometer. Albeit the qualities are solid, I don't know whether this is the most ideal approach to do it, any remark on this is invited.

8.4 AVOIDING FALSE TRIGGER DUE TO SUNLIGHT WITH IR SENSOR

The following arrangement of code that needs blunder amendment is the manner in which TCRT5000 is utilized in this task. It is feasible to utilize it as a straightforward position sensor, however then the greatest disadvantage with the IR position sensor is that it will get set off if IR beams from the sun straightforwardly fall on it.

To stay away from this issue, we measure two qualities from our TCRT5000 sensor as clarified in the circuit, the producer Drove of the IR sensor is associated with a computerized pin and the beneficiary Drove is associated with the Simple pin. Presently in our program, we will peruse two qualities from our IR sensor, one is Clamor and the other is Commotion in addition to Flag. The Clamor worth will be estimated while keeping the producer IR Drove killed, so the beneficiary IR Drove will just tell about the daylight force present in the climate. At that point we will quantify the Commotion In addition to flag in the wake of turning on the IR Drove. At that point in the program, we just need to take away Commotion from Clamor In addition to Flag and we will get our Sign worth. The code to do that is shown below.

When we know the Sign and Commotion esteem, we can contrast it with our Range_sensitivity worth to check if the sensor is in nearness to skin and if indeed, we can send the temperature esteem through sequential correspondence if not, we will simply send position_error as yield. In the event that the clamor esteem is exceptionally high (for this situation more prominent than 500), it implies the sensor is confronting direct daylight and we won't peruse the temperature for this situation since I discovered the sensor esteems entirely questionable when it is confronting direct daylight. Once more, this should help stay away from bogus readings.

9. RESULT

Table -1: Readings

So.No.	infrared thermometer [°C]	Mercury Thermometer[°C]
1	36.12	36.2
2	36.77	36.3
3	36.22	36.2

The hardware (infrared thermometer) result is displayed at the display in terms of body temperature of mouth and forehead. Mercury thermometer is only used for temperature measurement of body through oral and armpit. The normal oral temperature is close to the body's temperature.

Hence in this corona situation we have contactless measurement of temperature through infrared thermometer.

10. CONCLUSION

In this paper, the infrared temperature for the estimation of body temperature, the estimation of the traditional contact measuring system is unbroken far from, it's particularly appropriate for estimating internal heat level for babies and little children. The deliberate temperature is shown through the OLED or automaton module it can be utilised by a person of helpless vision. Non - contact estimation, estimating speed is quick, the internal heat level is calculable within the larger progression of people.

11. ANDROID APPLICATION

The Android application is the most feature-rich aspect of this project. We won't dive into subtleties on how we can built up an application. The Android application permits us to store all the temperature data with a photo and furthermore share it as a dominate document through Whatsapp Email, and so on.

12. ACKNOWLEDGEMENT

At the very outset, We like to record our heartfelt gratitude to our respected teacher and mentor 'Shri. U K JHA', Assistant professor, Department of Electrical & Electronics Engineering for his valuable guidance and suggestion throughout our research and project work.

13. REFERENCES

- [1] Jing Zhang, Development of a Non-contact Infrared Thermometer,(AER)volume 153 pp 308-312(AETR 2017)
- [2] Gostic, K.M. Gomez, A.C.R., Mummah, R.O., Kucharski, A.J., Lloyd-Smith J.O., Estimated effectiveness of symptom and risk screening to prevent the spread of COVID-19. eLife, 2020. 9 e55570

- [3] Priest, P.C., et al., Thermal Image Scanning for Influenza Border Screening: Results of an Airport Screening Study.External Link Disclaimer Plos One, 2011. 6(1): p. e14490.
- [4] Aw J, The non-contact handheld cutaneous infra-red thermometer for fever screening during the COVID-19 global emergency, External Link Disclaimer J Hosp Infect 2020 104(4):451
- [5] Datasheet of MLX90614 <https://www.melexis.com/en/product/MLX90614/Digital-Plug-Play-Infrared-Thermometer-TO-Can>
- [6] Does the infrared thermometer detect temperature accurately? <https://covid.aiims.edu/does-the-infrared-thermometer-detect-temperature-accurately/>
- [7] <https://circuitdigest.com/microcontroller-projects/ir-thermometer-using-arduino-and-ir-temperature-sensor#:~:text=The%20entire%20circuit%20is%20powered,module%2C%20Sensor%20and%20Laser%20diode.>
- [8] https://create.arduino.cc/projecthub/Aswith_mkr/contactless-smart-thermometer-using-arduino-mlx90615-ir-9b3772
- [9] <https://maker.pro/arduino/projects/ir-thermometer-for-covid-19>
- [10] <https://theorycircuit.com/infrared-thermometer-arduino/>
- [11] Muhammed et. al., Vol.7 [Iss.8]: August 2019] ISSN- 2350-0530(O), ISSN- 2394-3629(P) DOI: <https://doi.org/10.29121/granthaalayah.v7.i8.2019.639>
- [12] <https://www.adafruit.com/>

14. BIOGRAPHIES

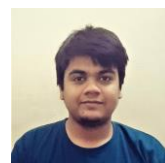

I, Kanad Jaiswal is a 4th year undergraduate student at Maharaja Agrasen Institute Of Technology. I am pursuing my Bachelor Of Technology in Electrical and Electronics Engineering. I had an opportunity to work as an intern in New Delhi Municipal Corporation. (NDMC). I keep on learning more about electrical engineering through non-academic courses, training and my friends. My interests mainly lie in the field of power distribution, switchgears and traction motors and controllers.



I, Sunny Sah is a 4th year undergraduate student at Maharaja Agrasen Institute Of Technology. I am pursuing my Bachelor Of Technology in Electrical and Electronics Engineering. I had an opportunity to

work as an intern in New Delhi Municipal Corporation. (NDMC) and Delhi metro Railway corporation (DMRC). I keep on learning more about this field through non-academic courses, training and my friends. My interests mainly lie in the merging of hardware and software components for easier and safer handling of technologies which are to come.

I, Ashutosh Kumar Happy is presently a 4th year engineering student from Maharaja Agrasen institute of technology (Electrical and Electronic Engineering). Being from an engineering atmosphere I always had a hanker to explore new and emerging sectors and solve some challenging problems. Following the path of being an engineer I had an opportunity to work as an intern in some leading organizations in India such as Delhi Metro Railway Corporation (signalling & telecommunication), Power Grid Corporation of India Limited (DTL Project). During Pandemic of Covid-19 the Fever is the symptoms of this and I came along one such drawback in thermometer which I, with my friends tried to solve and after months of hard work we are pleased to share this paper with you all.



I, Udyan kumar jha an Assistant professor at Maharaja Agrasen Institute Of Technology. I have been actively working on ways to improve the existing electrical systems using computer science and artificial intelligence. I believe that it is one of the best ways to enhance the efficiency of the system and also help in sustaining the environment.

