

Design and Analysis of underground water tank by using Staad Pro

Komal K Wagh¹, Akshay K Ghuge², Deepak N Gaidhane³, Gajendra R Gandhe⁴

^{1,2}M.Tech Student, Department of Civil Engineering, DIEMS Aurangabad, Maharashtra, India

³Assistant Professor, Department of Civil Engineering, DIEMS Aurangabad Maharashtra, India

⁴Professor, Department of Civil Engineering, DIEMS Aurangabad, Maharashtra, India

Abstract - Water tank is a structure used to store water for supplying to households as drinking purpose, for industries as a coolant and irrigational water for agricultural farming in some areas. Water tanks are classified on bases of their shapes and position of structure. In this paper, we had discussed about the design of underground water tank of Rectangular shape are Designed and analysed using Staad pro. Underground water tank faces different type of loads compared to other structures, they mainly face horizontal or lateral loads due to earth pressure and water pressure or any liquid pressure which is been stored in the tank. The side walls of the underground water tank will face greater load at the bottom and the load linearly decreases towards the top.

Key Words: water tanks, structural design and analysis, loading applications, plates stress contouring's.

1. INTRODUCTION

Underground water tanks are structures which act as a reservoir for small domestic or commercial buildings. Basic components of underground water tanks are Base slab, Side walls, and Roof slab. Tanks are very ductile, enabling to withstand seismic forces and varying water backfill. Tanks utilize material efficiently – steel in tension, concrete in compression. Underground water tanks have Low maintenance throughout the life as these are built with concrete, durable material that never corrodes and does not require coatings when in contact with water or the environment. The main advantage of underground water tank is that the temperature is lower than the overhead tanks, which will reduce evaporation inside water tank. Underground water tank faces different type of loads compared to other structures, they mainly face horizontal or lateral loads due to earth pressure and water pressure or any liquid pressure which is been stored in the tank. The side walls of the underground water tank will face greater load at the bottom and the load linearly decreases towards the top.

The underground water tank not only faces loads inside the tank it also has to bear the surcharge above the ground

level. So the roof slab of the underground tank should have enough strength to with stand the surcharge.

1.1 Importance of Underground Water Tank

a) Seepage

It is very important to store water and not to lose it. The tank should have a durable, watertight, opaque exterior and a clean, smooth interior. Below ground tanks must also be plastered well and correctly installed, otherwise they can collapse.

b) Evaporation

All storage tanks should have a roof made from locally available materials. A tight fitting top cover prevents evaporation.

c) Safety

We should prevent mosquito breeding and keeps insects, rodents, birds and children out of the tank. A suitable overflow outlet(s) and access for cleaning are also important.

d) Storage of water

It is very imperative for all tanks to store water because the main process of the tank is to store water due to lack of running fresh water in all areas.

e) Emergency

Underground tanks are used as reservoirs where water is pumped to overhead tanks. When water is not available it will help us store and use water.

1.2 Different Types of Water Tanks

1.2.1 Depending On Its Location

a) Resting On Ground

- Deals with normal pressure of gravity and corresponding outward pressure of water stored in water tank (Internal hydrostatic pressure).
- Pipes can be attached directly for irrigation purpose.
- Pumps can be attached depending on the usage.
- It is more economical than other type of tanks.
- No need for excavation.

b) Overhead

- The water pressure to all the processes being supplied is held at a relatively constant level.
- In power failure or pump failure pressure remains constant.

- At work any pipe can be taken for maintenance. If all the pumps are failed water pressure will be still for fire suppression and other critical needs.
- Gravity plays an important role for the flow of water.
- Columns are provided for the support of tank.

c) Underground

- Used as water reservoir for irrigation purpose.
- Used for rainwater harvesting.
- Difficulty in installation.
- It is protected from animals in forest areas.
- Pumps are needed for supply of water.
- Expensive compared to tanks resting on the ground.
- In case of fire the water will be safe underground.

1.2.2 Based On Material

a) Plastic Tank: Poly (plastic) water tanks are made from polyethylene; a UV stabilized food grade plastic. The tanks are light, you only need a sand base to place them on, and they come in a wide variety of colours and have a long serviceable life. Many poly tanks carrying a 25 year warranty, although many claim 15 years is a very realistic lifespan. They are also usually the second cheapest. One of the major disadvantages of polyethylene is the material is made from petrochemicals. Even after their serviceable life has ended, there's still a great big hunk of plastic that will take generations to break down and will release toxins as it does so. However, polyethylene tanks can still be easily recycled after 15 years, so it's just a matter of breaking the tank up and then carting it away rather than trying to squeeze a few more years out of one. Some poly tanks are made with a vertical seam - this is a weak point that may cause splitting and subsequent water loss. Polyethylene water tanks and fire don't really mix either - they'll just melt. This can be a real problem if you're in a rural area and you need that water to fight a fire. The other issue is the long term effects of drinking water stored for such a long time in this material. Polyethylene tanks are relatively new on the market, it is not known if there are any credible serviceable life studies that have been done in relation to these issues. Some people do note a bit of an odd taste to the water if the tank is placed in full sun. Just on that point - before purchasing a poly tank, check the warranty for temperature stipulations as some manufacturers will void the warranty if conditions where the tank is installed can get extremely hot.

b) Steel Tanks: Steel tanks Galvanized tanks have been around for over 150 years and are usually the cheapest type of tank. Hot-dip galvanizing is a process used to coat steel or iron with zinc. The Zinc helps slow down corrosion, but depending on environmental factors, a galvanized tank may last well under 5 years. This is due to electrolysis. Some metal tanks now also have polyethylene linings to further help retard corrosion - escaping plastic

altogether can be a difficult thing to do these days. With a steel based tank, seriously consider the composition of the water you are storing and its potential to accelerate corrosion in any exposed metals.

c) Fiber Glass: Fiber glass, this is another long-lasting option that can be installed above or below ground. Fiberglass tanks resist corrosion and are not generally affected by chemicals. As fiberglass tanks tend to allow more light in than other types of tank materials, this can encourage the growth of algae, so they should be painted. Fiberglass can also tend to be brittle, leaving it prone to cracks - something you don't want, particularly in an in-ground situation.

d) Concrete Tank: Concrete water storage tanks can be built above grade or mostly hidden from view. They are built on site because of the material's weight. Concrete is a porous material and needs to be sealed to prevent minerals leaching into the water. With proper sealing and construction techniques, this is can be addressed. Mining production and delivery of concrete is energy intensive. The advantage is achieved by its long life and its ability to be simply recycled. Choosing a tank material Choice is wonderful, but as you can see, there are advantages and disadvantages with each type of tank, particularly when it comes to environmental impact - so it's really a matter of gagging your needs and budget and then choosing the lesser of the evils. In regards to the financial side of things, bear in mind not just the initial cost, but how many times the tank will need replacing over X years. This also plays a role in the Concrete tanks have been used in rural areas for many years but are becoming more common in the city, particularly pre-cast underground concrete tanks that can be placed under driveways or front and back yards. The advantage of underground concrete tanks is that they can collect large volumes of water in properties tight for space that could not otherwise accommodate above-ground tanks. Houses with small gardens still consume large volumes of water internally through laundries, toilets and showers and could benefit from using underground concrete tanks for 'whole of house' water supply.

2. DESIGN OF UNDERGROUND WATER TANK

2.1 Design steps are involving:

1. Stability
 - a. Uplift Check
 - b. Check of Stresses on Soil
2. Strength
 - a. Design of Critical Sections.

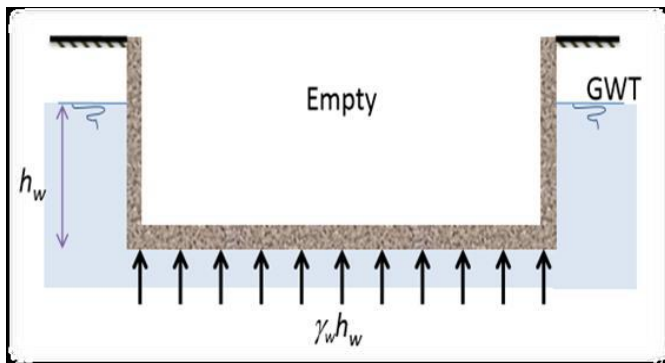

Fig -1: Sketches Show the results when tank empty

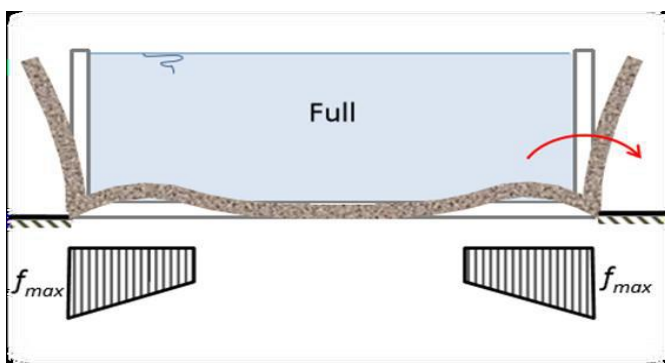

Fig -2: Sketches Show the results when tank is full

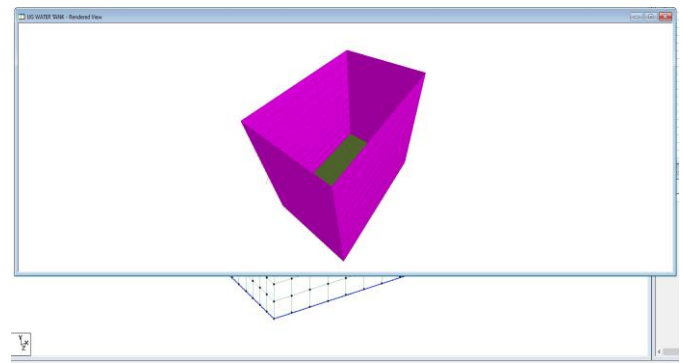

Fig -4: 3D Rendering view of Tank

3.2 Creating Surface Plate

Using the plat cursor select all 4 bottom point to create the surface plate.

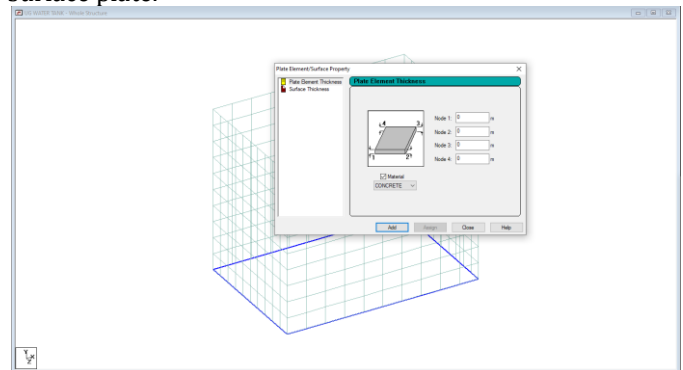

Fig -5: Define the Property of Surface Plate

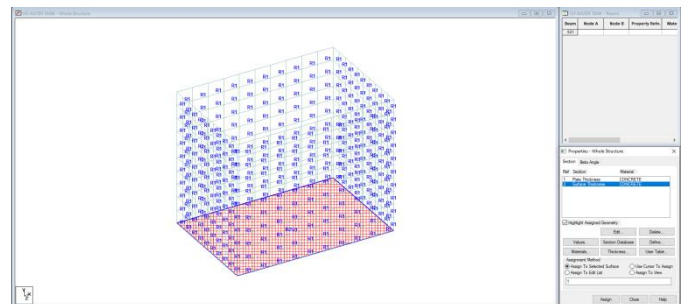

Fig -6: Define the thickness of Plate

3. MODELING AND ANALYSIS

Table -1: Structural Configuration

Sr.no	Parameter	Size
1	Capacity of water tank	200m ³
2	Shape of water tank	Rectangular
3	Unit weight of soil	34.93 KN/m ³
4	Angle of internal friction (ϕ)	37°
5	Bearing capacity of soil	230 KN/m ²
6	Free board	0.25 m
7	Size of Tank	10x5x4.25 m
8	Grade of concrete	M25

3.1 Creating Model

The Model is generated based on the dimensions of the tank.

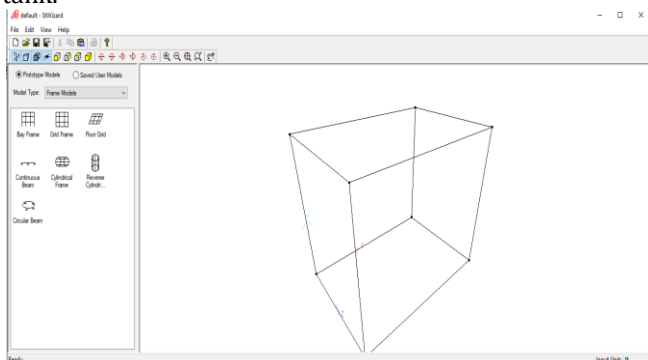

Fig -3: 3D Model of Tank

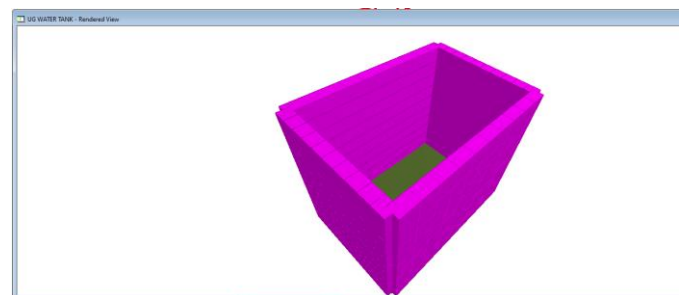

Fig -7: 3D View of Tank with Thickness

3.3 Assigning of Support

Selecting the support button the Fix Support is created and assign to 4 Corner of Structure.

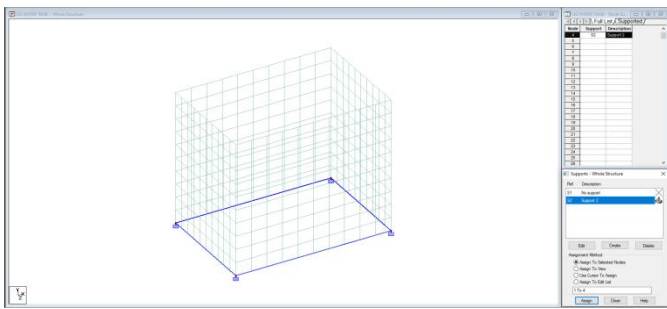

Fig -8: Support Assigning

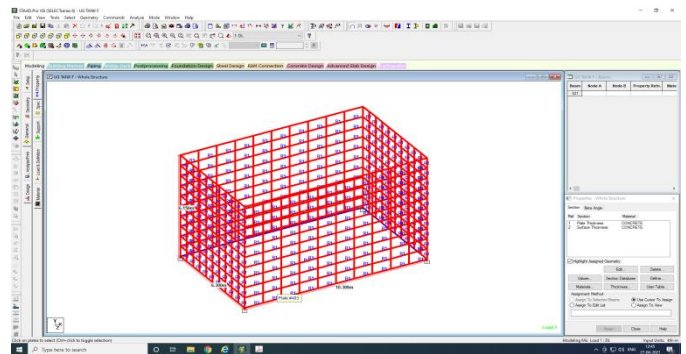

Fig -12: Define Material and IS Code

3.4 Creating and Assigning of Load on Structure

Selecting the load and definition button the load is created.

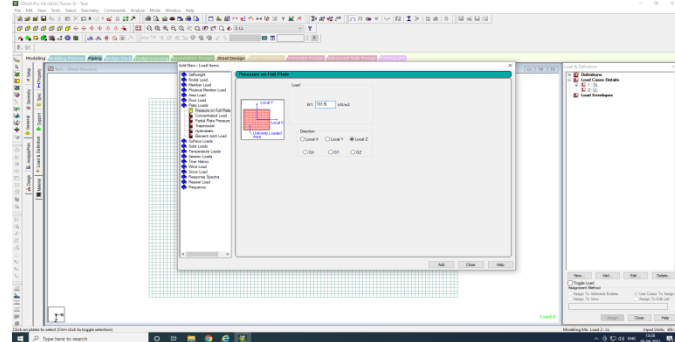

Fig -9: Load Creating and Assigning

4. CALCULATION AND DESIGN RESULTS

4.1 Stress Contour

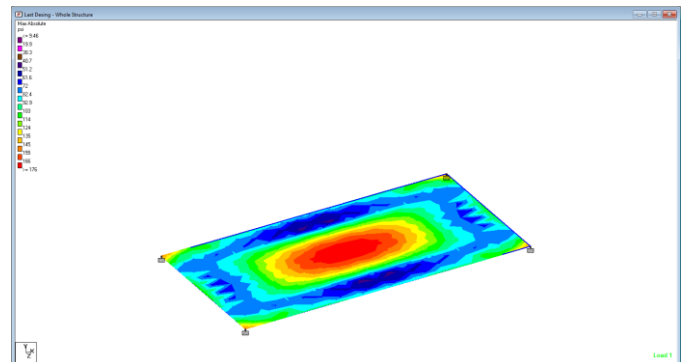

Fig -13: Stress Due to Dead Load

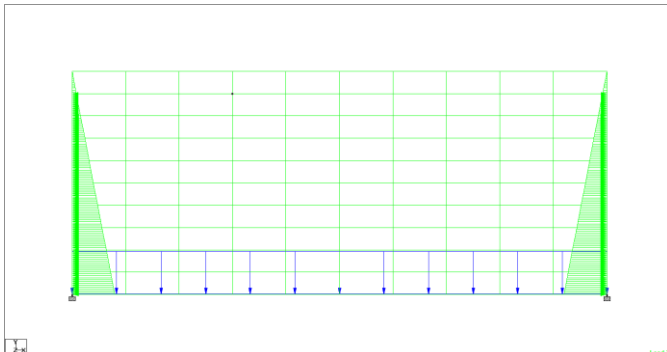

Fig -10: Water Pressure on side wall as well as at base

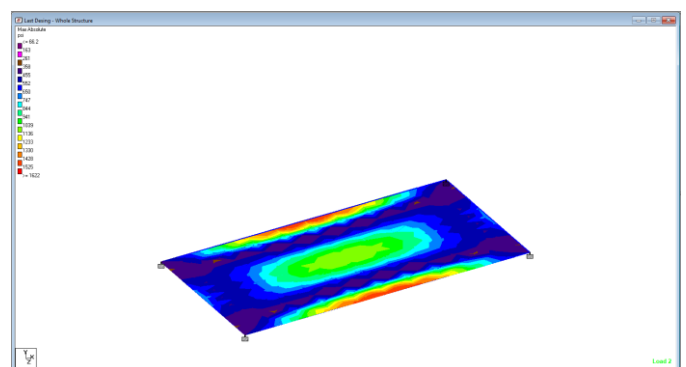

Fig -14: Stress Due to live Load

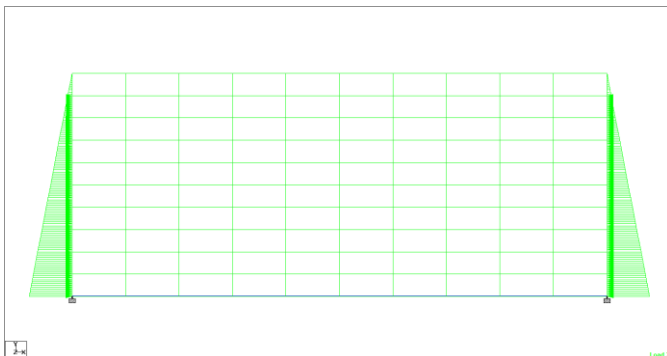

Fig -11: Soil Pressure on Side Wall

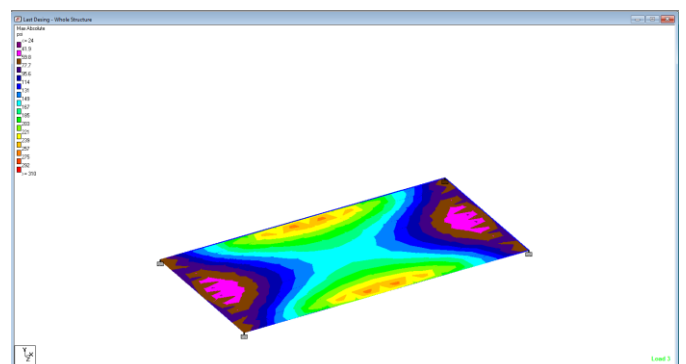

Fig -15: Stress Due to Soil Pressure

3.5 Material Confirmation and IS Code

Confirming the Material as Concrete and selection of is code IS456 for Tank designing

4.2 Deflection

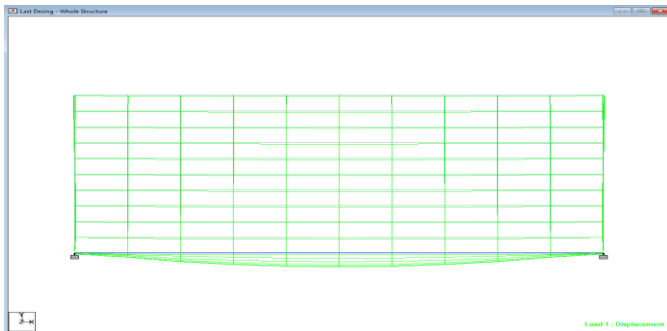

Fig -16: Deflection Due to Dead Load

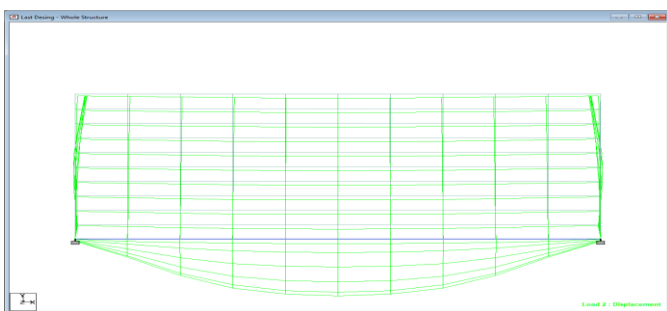

Fig -17: Deflection Due to Live Load

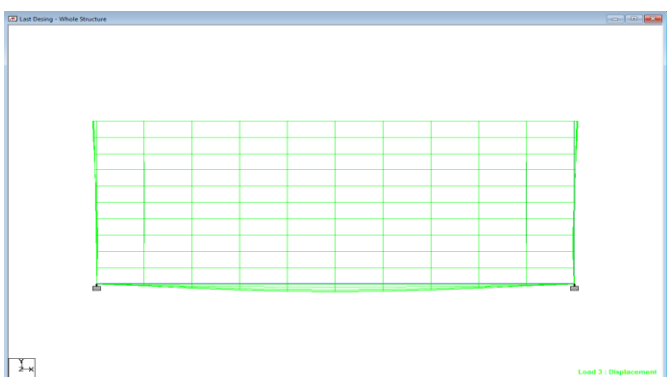

Fig -18: Deflection Due to Soil Pressure

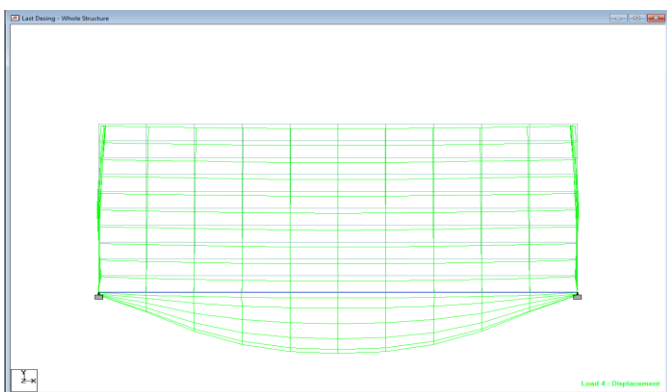

Fig -19: Deflection Due to All Load

4.3 Support Reaction and Bending Moment

Table -2: Structural Configuration

			Horizontal		Vertical	Moment		
	Node	L/C	Fx kN	Fy kN	Fz kN	Mx kip-in	My kip-in	Mz kip-in
Max Fx	1	2 LL	278.435	552.810	116.380	-198.018	37.919	285.792
Min Fx	2	2 LL	-278.435	552.810	116.380	-198.018	-37.919	-285.787
Max Fy	1	2 LL	278.435	552.810	116.380	-198.018	37.919	285.792
Min Fy	3	3 SP	-75.219	-18.306	13.159	-3.701	0.241	45.377
Max Fz	2	2 LL	-278.435	552.810	116.380	-198.018	-37.919	-285.787
Min Fz	4	2 LL	-278.435	552.810	-116.380	198.018	37.919	-285.788
Max Mx	4	2 LL	-278.435	552.810	-116.380	198.018	37.919	-285.788
Min Mx	2	2 LL	-278.435	552.810	116.380	-198.018	-37.919	-285.787
Max My	4	3 SP	-60.697	18.306	-26.045	-3.751	61.144	6.228
Min My	2	3 SP	-60.697	18.306	26.045	3.751	-61.144	6.228
Max Mz	3	2 LL	278.435	552.810	-116.380	198.018	-37.919	285.792
Min Mz	4	2 LL	-278.435	552.810	-116.380	198.018	37.919	-285.788

4.3 Statical Check Result

Table -3: Structural Configuration

L/C		Fx kN	Fy kN	Fz kN	Mx kip-in	My kip-in	Mz kip-in
1	Loads	0.000	-868.780	0.000	19992.358	0.000	-39215.705
	Reactions	-0.000	868.780	-0.000	-19992.358	0.000	39215.705
	Difference	-0.000	0.000	-0.000	-0.000	0.000	0.000
2	Loads	-0.000	-2211.242	0.000	50885.057	-0.004	-99812.804
	Reactions	0.000	2211.242	-0.000	-50885.057	0.004	99812.804
	Difference	-0.000	0.000	0.000	-0.000	-0.000	0.000
3	Loads	0.000	0.000	-0.000	-0.000	0.001	-0.000
	Reactions	-0.000	-0.000	0.000	0.000	-0.001	0.000
	Difference	0.000	-0.000	-0.000	-0.000	0.000	-0.000

5. Area of steel

Table -4: Steel Required at Base Slab

DESCRIPTION	STAAD RESULT
Total Steel	2195 MM2
Steel On Each Face	1097 MM2

Table -5: Steel Required In Side Wall

DESCRIPTION	STAAD RESULT
Total Steel	3368 MM2

6. CONCLUSIONS

- The project was aimed on the analysis and design of underground water tank.
- It was analysis using STAAD.PRO using generic loading which proved to be premium software of great potential in analysis and design sections of construction industry.
- The analysis and design were done according to standard specifications.

- Used IS-456:2000 & SP-16, for the design of the STRUCTURAL MEMBERS. i.e., followed the LIMIT STATE method.
- Materials used are M20 grade concrete and Fe 415 steel unless mentioned in the particular design elements.
- STAAD Pro gives satisfactory results when compare with manual design also.
- SATABAD PRO analysis and design is always beneficial over the conventional method of analysis and design of water tank.
- Manual analysis and design requires lengthy and complicated procedure while STAAD PRO requires less time & easy design & analysis process.
- By using STAAD PRO software there is saving of 15% to 20 % of total steel in the whole structure.

7. REFERENCES

1. Indian Standard Plain & Reinforced Concrete Code of Practice (Fourth Revision), IS-456, 2000.
2. Shinde Suraj Parbat, Prof.Kulkarni V.P, "Design Of Underground Water Tank By Using Staad- Pro And E-Tabs Software", International Journal Of Engineering Sciences & Research Technology, ISSN: 2277-9655
3. Issar Kapadia, Purav Patel, Nilesh Dholiya and Nikunj Patel (2017). "Design, Analysis and Comparison of Underground Rectangular water tank by using STAAD Pro v8 software". International Journal of Scientific Development and Research (IJS DR), January 2017, Volume2, Issue 1, ISSN: 2455-2631.
4. Nallanathel. M, Ramesh. B, Jagadeesh. L(2018). "Design and Analysis of Water Tanks using Staad Pro". International Journal of Pure and Applied Mathematics, Vol.119, No.17, 3021-3029 pp, ISSN: 1314-3395 (on-line version). url: [http://www.acadpubl.eu/hub/ Special Issue](http://www.acadpubl.eu/hub/Special%20Issue).
5. Abdul Qayyum Ansari, Jitesh Chourasia, Prof. Manoj Deosarkar, Prof.Arya Geetha, Rishab Gupta, Shahid Shaikh, "Design Calculation Of Overhead Water Tank Using Manual Method", IJARW ,ISSN (O) - 2582-1008.
6. Mohammed Azgar, N. Ramya Smruthi, "Design Of Circular Water Tank By Using Staad Pro Software", Issn 2319-8885 Vol.06, Issue.29.
7. Prashanth.P, Anshuman.S, Pandey.R.K, Arpan Herbert, "Comparison of design results of a Structure designed using STAAD and ETABS Software", International Journal of Civil and Structural Engineering Volume 2, No 3, 2012.
8. Shenbagam.N, Mahesh.V, Chandramohan.N, Jayanthi.V, Manjunath.N.V, "Optimal Design Of Underground Water Tanks", International Journal of Engineering Technology, Management and Applied Sciences, November 2014, Volume 2 Issue 6, ISSN 2349-4476.
9. Dr. H. K. Sharma, V. P. Singh, Satpal Sharma, "Some Aspects of Computer Aided Design of Underground Water Tanks", 2nd IASME / WSEAS International Conference on GEOLOGY and SEISMOLOGY (GES '08), Cambridge, UK, February 23-25, 2008.
10. Ashwini B T, Chethan V R, Bhavya D R, "Design Of Overhead Rcc Rectangular Water Tank By Using Working Stress Method", International Research Journal Of Engineering And Technology (IRJET), Volume 05 Issue 06 June-2018, ISSN: 2395-0056.
11. Rashadus Sadain, Aakif Anjum, Tauseef Ahmed, "Comparative Analysis and Design of ESR by Manual and Software", IOSR Journal of Engineering (IOSR JEN), ISSN (e): 2250-3021, ISSN (p): 2278-8719.
12. Mainak Ghosal, "Water Tank Analysis Using STAAD PRO", International Transaction on Engineering & Science, Volume 1, Issue 2, January 2019