

DESIGN AND FABRICATION OF SINK-TOP DISHWASHER

Mahesh Chaudhari¹, Omkar Chavan², Piyush Bari³, Subhash Bongane⁴

¹(Mechanical Engineering, DR. DY Patil School of Engineering, Pune.)

²(Mechanical Engineering, DR. DY Patil School of Engineering, Pune.)

³(Mechanical Engineering, DR. DY Patil School of Engineering, Pune.)

⁴(Mechanical Engineering, DR. DY Patil School of Engineering, Pune.)

⁵(Prof. Amol Gaikwad, Dept. of Mechanical Engineering, DYPSOE, Pune.)

Abstract - An Automation is maximizing at the tremendous rate, especially in the mechanical sector and is giving a hope of new shine. Industrial automation has led to a structural shift in the labor market, particularly in the manual jobs which intern has resulted in increasing the production. Subsequently, the effect of automation at the domestic level is still moderate.

The aim of our project is to make dishwasher which will simulate handwashing and allow the cookware to be washed mechanically with the timeline and the budget in mind, which can be useful at the domestic level thereby, the process will be smoother and less clumsy. The project will be useful for households to clean pans, dishes and plates immediately after use in less time. By taking into consideration various points such as literature review, problem identification, data collection, design of final product we can manufacture a Sink-Top Dishwasher.

Key Words: (Design, Manufacturing)

1. INTRODUCTION

One of the most often used tools in a residential kitchen is the cook's favorite dishes, plates or pan, but many dead washing the dishes by hand. Even those who own a dishwasher often chose to handwash their cookware, whether due to space issues in the dishwasher or due to the aggressive methods used in modern dishwashers. Dishwashers aren't necessarily run after each meal, but a certain pot or pan may be needed for both lunch and dinner, requiring an immediate wash. By the end of our project, we hope to have created a device that will simulate hand washing and allow these kinds of cookware to be mechanically washed.

Thus, the attempt has been made to make a dishwasher with objectives that it should minimize human efforts and should have low cost with less time consumption and must have all the basic mechanisms washing with soap water, scrubbing with brush and rinsing in clean water.

1.1 Problem Statement

- Design and development a prototype model of showing the concept of Sink-Top Dishwasher.

- Dishwasher which can settled on the sink top and simulate handwashing and use minimum amount of water.
- Allowing cookware to be mechanically washed in the stages, immediately after the use in very less time and work according to the need.

1.2 Objectives

- To design and develop a prototype model showing the concept of Sink-Top Dishwasher machine.
- Our main objective is to reduce the cost and make the setup more compact.
- To avoid the wastage of water, as in the case of other washers.
- To give immediate wash and good cleaning performance.
- To reduce human efforts and time consumption

2. METHODOLOGY

This chapter deals with the methodology that was adopted for progression of the project work.

- Topic Selection
- Advancements for setup.
- Design(2D-3D) of dishwasher on PTC Creo.
- Estimation of Polycarbonate sheets required.
- Manufacturing

Design concept generation refers to the actual conceptual design where the design concept is an approximate description of the technology, working principles and form of the product. It has a detailed description on how the product will satisfy and meet customer requirements. Existing design constraints may even be solved by having a good development in the design concept.

For this project, many alternative concepts have been generated. The concepts that gave the most advantages were considered as the best concept and a wait's further evaluation. Design concept generation is usually expressed in the form of 2-D and 3-D models.

3. WORKING PRINCIPLE

Arduino uno as a controller used here which controls all the operations. When we start the machine, the Arduino controls the functioning of electric motor and pump. And the relay will provide time delay options for the working of both. The pump is meant for taking the water and soap solution from the 2 tanks simultaneously according to the commands. The soap solution is then surged through the pipes present in the dishwasher and sprayed on the object present in the dishwasher, simultaneously the motor starts with rotating the brush, it effectively carries out some cycles till the object is cleaned, while the pump keeps surging the water through out in low stream to enhance cleaning. At the end of cycle of brush final stream of water is sprayed and the object is ready to be taken out. End of the process will be indicated by the red light on the washer unit frame.

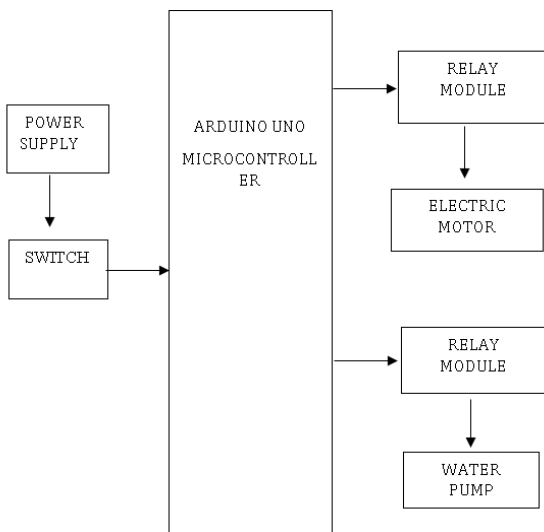

Fig.1 Block Diagram

4. DESIGN AND CALCULATIONS

4.1 Estimate of Polycarbonate sheets required

- Main Unit

$$\text{Area} = \text{Length} * \text{Breadth}$$

$$= 2 (15.3 * 7) = 214.2 \text{ sq.in}$$

$$= 2 (15.3 * 16.5) = 504.9 \text{ sq.in}$$

$$= 2 (16.5 * 7) = 231 \text{ sq.in}$$

$$\text{Volume} = \text{Length} * \text{Breadth} * \text{Height}$$

$$= 15.3 * 16.5 * 7$$

$$= 1767.15 \text{ cubic inches}$$

- Utility Box

$$\text{Area} = \text{Length} * \text{Breadth}$$

$$= 2(8 * 15.3) = 244.8 \text{ sq.in}$$

$$= 2 (5 * 15.3) = 153 \text{ sq.in}$$

$$= 2 (5 * 8) = 80 \text{ sq.in}$$

$$\text{Volume} = \text{Length} * \text{Breadth} * \text{height}$$

$$= 10.3 * 8 * 5 = 412 \text{ cubic inches}$$

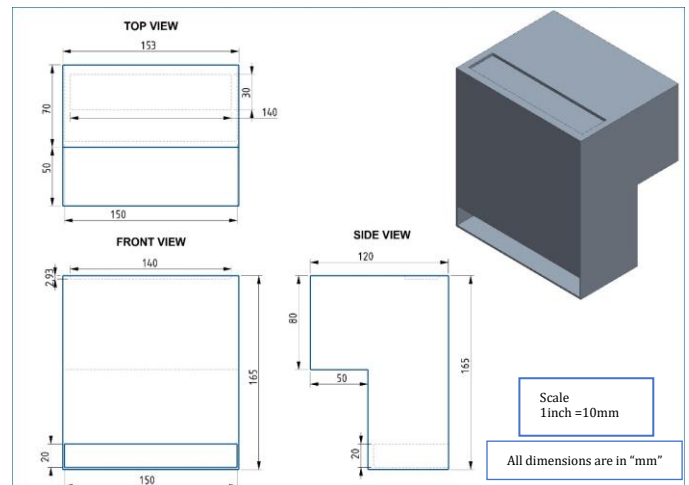

Fig.2 2D & 3D Model of Dishwasher

4.2 Volumes

- **Water Tank**

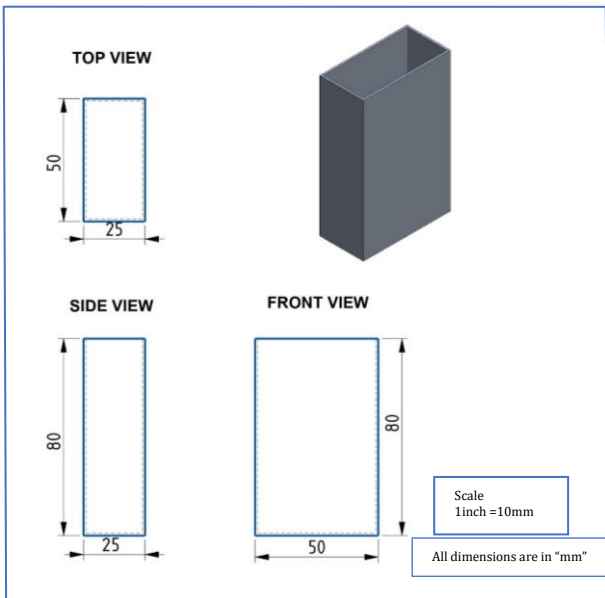

Fig.3 2D & 3D View of Water Tank

$$\begin{aligned} \text{Volume Water Tank} &= L*B*H \\ &= 2.5*5*8 \\ &= 100 \text{ cubic inches} \end{aligned}$$

- **Soap Tank**

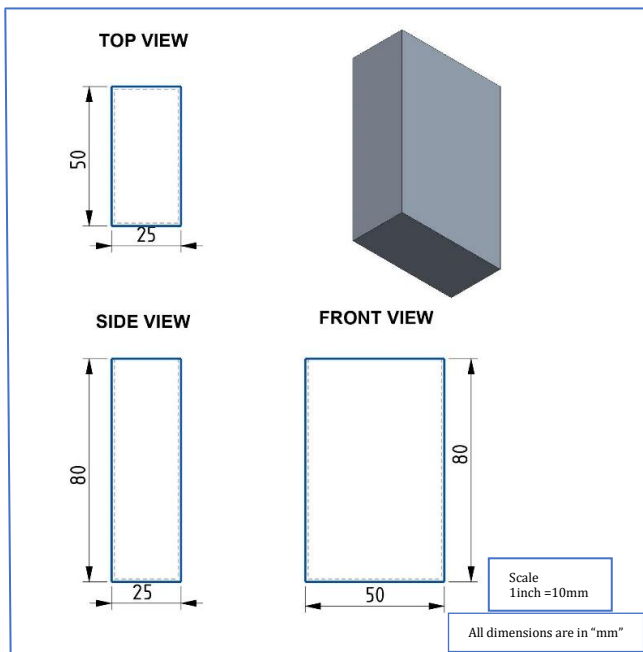

Fig.4 2D & 3D View of Soap Tank

$$\begin{aligned} \text{Volume of Soap Tank} &= L*B*H \\ &= 2.5*5*8 \\ &= 100 \text{ cubic inches.} \end{aligned}$$

- **Drainage Box**

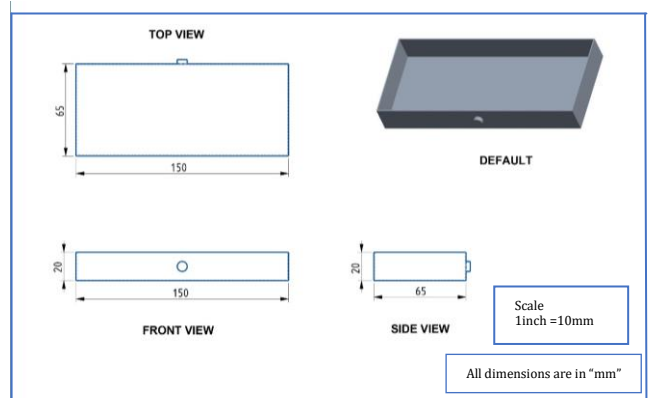

Fig.5 2D & 3D View of Drainage Box

$$\begin{aligned} \text{Volume of Drainage Box} &= L*B*H \\ &= 15.3*6*2 \\ &= 183.6 \text{ cubic inch} \end{aligned}$$

4.3 Design of Brush Plate

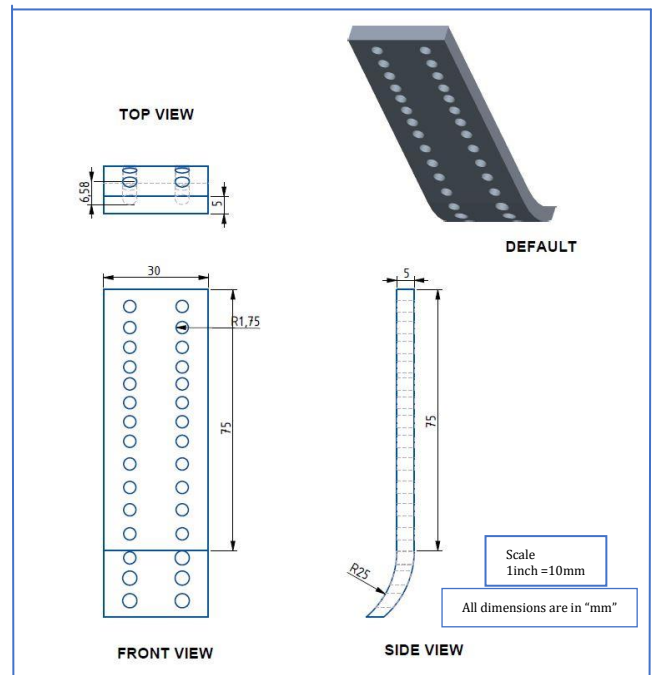

Fig.6 Brush Plate design

Major cleansing action will be provided by the brush. Stainless steel plate will be provided and punched with the holes to attach the brush heads. This stainless plate will rotate along with the brush heads, which will be powered by the electric motor. The brush can be replaced or cleaned as needed. It can be removed from the unit for cleaning purposes. The brush heads will be made up of synthetic bristles.

5. COMPONENTS

5.1 Polycarbonate Sheets

Polycarbonate (PC) plastics are a naturally transparent amorphous thermoplastic. Although they are made commercially available in a variety of colors (perhaps translucent and perhaps not), the raw material allows for the internal transmission of light nearly in the same capacity as glass. Polycarbonate polymers are used to produce a variety of materials and are particularly useful when impact resistance and/or transparency are a product requirement.

Polycarbonate also has very good heat resistance and can be combined with flame retardant materials without significant material degradation. Polycarbonate plastics are engineering plastics in that they are typically used for more capable, robust materials such as in impact resistant “glass-like” surfaces.

Property	Value
Technical Name	Polycarbonate (PC)
Chemical Formula	C ₁₅ H ₁₆ O ₂
Melt Temperature	288-316 °C (550-600 °F) ***
Typical Mold Temperature	82 - 121 °C (180 - 250 °F) ***
Heat Deflection Temperature (HDT)	140 °C (284 °F) at 0.46 MPa (66 PSI) **
Tensile Strength	59 MPa (8500 PSI) ***
Flexural Strength	93 MPa (13500 PSI) ***
Specific Gravity	1.19
Shrink Rate	0.6 - 0.9 % (.006 - .009 in/in)

Table -1: Properties of PC

5.2 Arduino Uno

The Arduino Uno is a microcontroller board based on the ATmega328. It has 14 digital input/output pins of which 6 can be used as PWM outputs, 6 analog inputs, a 16 MHz ceramic resonator, a USB connection, a power jack, an ICSP header, and a reset button. It contains everything needed to support the microcontroller; simply connect it to a computer with a USB cable or power it with an AC-to-DC adapter or battery to get started.

Microcontroller	ATmega328
Operating Voltage	5V
Input Voltage (recon.)	7-12V

Input Voltage (limits)	6-20V
Digital I/O Pins	14
Analog Input Pins	6
Flash Memory =32 KB	32KB
RAM =2 KB	2KB
Clock Speed	16 MHz
EPROM	1KB

Table -2: Features of Microcontroller

5.3 DC Motor

A DC motor is any of a class of electrical machines that converts direct current electrical power into mechanical power. The most common types rely on the forces produced by magnetic fields. Nearly all types of DC motors have some internal mechanism, either electromechanical or electronic, to periodically change the direction of current flow in part of the motor. A DC motor's speed can be controlled over a wide range, using either a variable supply voltage or by changing the strength of current in its field windings.

5.4 Submersible Pump

A submersible pump is the one that is drenched in water it pumps water by uprooting. Submersible pumps are suited both to profound well and to surface water sources. Most profound wells utilize submersible pumps. These pumps are intended for high head and medium stream applications. A submersible water pump works underneath the surface. A pump will be fitted with the thin pipe to carry out the water from the tanks to spray out through nozzles on the objects to be cleaned as per the data from the controller.

5.5 Relay

A relay is an electrically operated switch. Many relays use an electromagnet to mechanically operate a switch, but other operating principles are also used, such as solid-state relays. Relays are used where it is necessary to control a circuit by a low-power signal (with complete electrical isolation between control and controlled circuits), or where several circuits must be controlled by one signal.

6. ADVANTAGES

- Work in any kitchen
- Direct disposal of waste, dirt and sink Ease of operation.
- Less wastage of water than other washers.
- Compact setup.

- Runs through quick cycle.
- Simplicity/ Cost effectiveness

7. FUTURE SCOPE

- This semi-automatic dishwasher can be converted into automatic model by adding robotics parts and using software to upgrade its functioning.
- The setup can be also converted into fiber body to enhance its look.
- This project can definitely change the comfort level of any house maker, also lots of upgrade can be made by customers experience with this project
- It can also be used in commercial purposes with the suitable upgrades.
- It is supportive to the smart city project

8. CONCLUSION

As the manual loading of dishes, pans and plates is considered an immediate wash is provided to the cookware in less amount of time. Although without the wastage of much water in the overall cycles. Compact body which can be afforded by everyone at the households considerably at the low cost than other market dishwashers. Overall maintenance cost is also low.

As discussed in the future works the device can be fully automated, which will give automated loading of washing articles.

ACKNOWLEDGEMENT

First and foremost, praises and thanks to the God, the Almighty, for his showers of blessings throughout our project work to complete successfully. We would like to express my deep and sincere gratitude to our guide, **Prof. Amol Gaikwad of Dr.D.Y. Patil School of Engineering** for giving us the opportunity to do this project and providing invaluable guidance throughout this project. His dynamism, vision, sincerity and motivation have deeply inspired us. It was a great privilege and honor to work and study under his guidance. We are extremely grateful for what he has offered us. Special thanks go to my Team mates for keen interest shown to complete this thesis successfully. Finally, our thanks go to all the people who have supported me to complete the research work directly or indirectly

REFERENCES

- [1] Fabrication of Automatic dishwashing machine KLN college of Engineering ICETSST-2017.
- [2] A Forced study in Brush scrubbing -research gate by kai Dong Xu .
- [3] www.researchgate.net/ use of polycarbonates.
- [4] PSG Design Data Book – Design of Machine Elements.