

DUAL COMPENSATION FOR PHOTOVOLTAIC FED UNIFIED POWER QUALITY CONDITIONER WITH VOLTERRA FILTER

Shenbagaramalakshmi¹, Kala Rani², Mohana³

¹Assistant Professor, Dept. of Electrical and Electronics Engineering, P.S.R Rengasamy College of Engineering for Women, Tamilnadu, India

²Student, Dept. of Electrical and Electronics Engineering, P.S.R Rengasamy College of Engineering for Women, Tamilnadu, India

³Student, Dept. of Electrical and Electronics Engineering, P.S.R Rengasamy College of Engineering for Women, Tamilnadu, India

ABSTRACT - This paper represents control and gestalt of photovoltaic fed unified power quality conditioner for the purpose of power quality improvement. The existing JAYA algorithm is used only for the purpose of improving the current quality using DSTATCOM and in previous modified JAYA algorithm have been implemented to improve both current and voltage quality in PV-UPQC using UV-PI and PR-R controller but it cannot easily reconcile to various condition. Due to presence of nonlinear load in distribution voltage and current quality is affected and harmonic is introduced in the system. Because of this reverse current will flow to transmission and generation get affected and energy loss can occur. In this paper by using Unified Power Quality Conditioner (UPQC) with Cascaded Asymmetric Multi Converter with Volterra filter, current and voltage quality is improved and harmonic can be reduced. In this paper VOLTERRA filter is proposed for employing the controlling the shunt and series inverter of PV fed unified power quality conditioner in precise manner.

Key words---Volterra filter, THD, PV-UPQC, voltage sag/swell

1. INTRODUCTION

Due to non-linear loads, it causes voltage and current-related power quality problems in the distribution system. The improved semiconductor-based system is the main reason for the current deviation. If voltage disturbance present in a non-linear load, it will behave aberrantly. Hence various power quality improvement devices or power conditioner is mostly for the power quality intensification [1],[2]. There is various type of power conditioner is used among these unified power quality conditioners have much attention due to high pursuance to reduce voltage and current deviation in the distribution system [2],[3]. In recently, the propagation of renewable energy in the distribution system is major interest due to its recurrent nature. To keep up the current quality in grid connected PV system various active filtering solution is

available [4]. The existing system along with PV grid has many merits, but in the point of common coupling (PCC) voltage deviation occur due to nonlinear load. Grid integration methodology with cost effective solution will be required to increase the power quality for future energy demand. In compared to conventional UPQC, grid connected UPQC gives better solution for power quality problems and helps to protect loads from voltage fluctuation[5],[6].

SRF, modified SRF theory [7], resonant controllers (PR-R and V-PI) [9], and UVTG controller [8], [10] has been applied on the conventional power control of inverter of UPQC for the generation of reference signals. Due to non-zero steady state error, traditional UPQC fails to operate on various dynamic condition and does not provide satisfactory performance. For improving the performance advanced controller of UPQC can be used which is responsible for perfect PI gain which simultaneously eliminate power quality issues under various dynamic condition. There is some limitations will be available on PV-DSTATCOM for selecting appropriate parameter to give perfect solution [9], [10] Classical optimization algorithm uses typical parameters like population size, number of generation. Ant colony bee uses number of onlooker bees[10].considering all these facts Dual compensator by Cascaded Asymmetric Multi Converter(CAMC) has progressive result. The proposed dual compensator have greater response and it converges faster.

Many online and automatic tuning methods are proposed to endure the changing condition of voltage and current in PV fed Unified Power Quality Conditioner. The existing JAYA algorithm have used for improvement of current quality by DSTATCOM. The modified JAYA algorithm have used for improvement of both current and voltage by PI and PRR controller for PV fed Unified Power Quality Conditioner. In modified JAYA The input voltage ripple under larger load variations are uncontrollable The dc load voltage to the VSI is oscillating since a PI controller is

employed for steady state controller it damps. Due to the nonlinear link variation the output current ripple is large and the reduction of the harmonic level deviates. Since the optimization used in gain tuning, it takes time to give response. In this paper A Back-to-Back dual compensator for UPQC is proposed. The scheme includes both shunt and series compensators. A dual compensation scheme based on the a three phase power-based PLL (3pPLL) scheme is employed This scheme used a self-tuning filter is placed between the utility voltages and by using 3pPLL scheme angular frequency can be calculated. Based on the modified 3pPLL is used to adjust the STF cut -off frequency, the variations in utility frequency can are reduced to improve the performance.

2. SYSTEM CONFIGURATION

Photovoltaic fed Unified Power Quality Conditioner using Cascaded Asymmetric Multi Converter with volterra filter is proposed in this paper. Both linear and nonlinear load is connected to grid connected power system. Unified Power Quality conditioner (UPQC) have both Series Inverter and Shunt Inverter is installed at distribution side. Series inverter is used for improving current quality is located at source side. Shunt Inverter is used for improving voltage quality is placed at load side. The series inverter and shunt inverter of Unified Power Quality Conditioner is connected to Dc link.

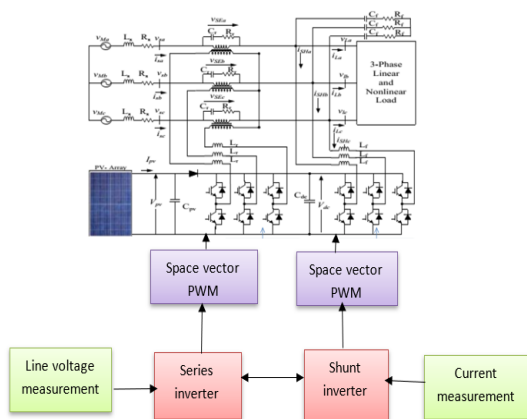

Fig-1: Block Diagram of PV fed UPQC

3. PROPOSED CONTROL SCHEME OF PV-UPQC

When Photovoltaic fed unified Power Quality Conditioner connected to the grid some difficulties arises in the UPQC. Proposed UPQC system, is UPQC system applied to proposed configuration using most advanced control scheme. The present system with traditional control scheme will be difficult and does not give satisfactory result. Unified Power Quality Conditioner have control

scheme of series inverter control, shunt inverter control and Voltterra filter. The UPQC system have Cascaded Asymmetric Multi Converter based control scheme.

3.1. DUAL COMPENSATION PRINCIPLE

To get the input current sinusoidal, balanced and in-phase with utility voltage, dual compensation technology is implemented, here the Series PWM converter is used to operate as sinusoidal current source. To isolate the harmonic current generated by non-linear load for this purpose impedance is used to be high. To make the output voltage sinusoidal, balanced, and in-phase with utility voltage Parallel PWM converter is used. To control the sinusoidal voltage source, impedance should be low to absorb load harmonic current. Hence Series and parallel converter have high and low impedance. By controlling the series converter to make sinusoidal and balanced references, compensation for load unbalance is required hence negative and zero sequence components can be compensated. BY controlling the series inverter current reference to be in-phase with utility voltage, reactive power can be compensated.

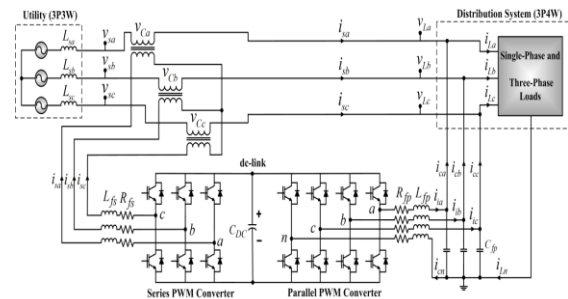

Fig -2: simulation for PV fed UPQC

3.2. PROPOSED SYSTEM WITH VOLTERRA FILTER

In nonlinear load it is difficult to calculate the required current to be compensated hence in compensator additional volterra filter is required to calculate the clear compensation current. Based on filtering the compensation current can be estimated.

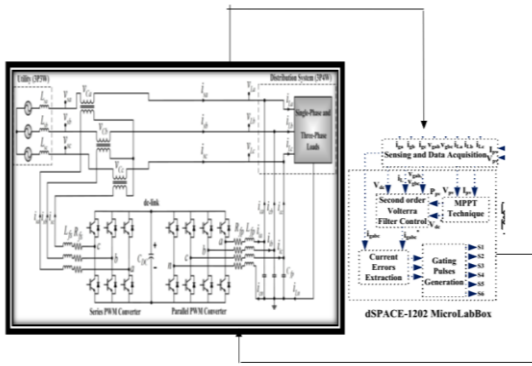

Fig - 3: PV fed UPQC with Volterra filter

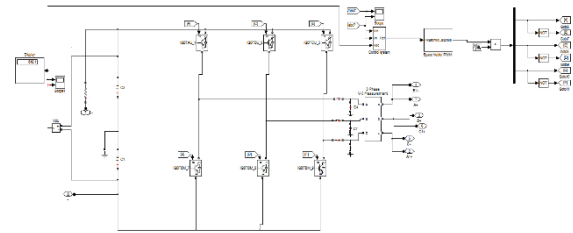

Fig -5: Series compensator

fig 5 shows that series compensator. It act as to control the sinusoidal current source. The current can be compensated

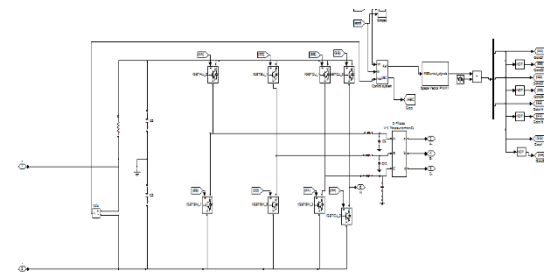

Fig-6: Shunt compensator

Fig 6 shows that shunt compensator where it act as to control sinusoidal voltage source. The voltage can be compensated.

4. RESULT AND DISCUSSION

To improve the performance of power quality, proposed dual compensator is implemented in PV fed unified power Quality Conditioner. To verify the efficiency and performance of proposed system, proposed model is simulated in MATLAB/Simulink software platform. The perfection of Dual compensated PV fed UPQC with Volterra filter is declared and compared the proposed result with modified JAYA algorithm based controller system result. By using Volterra filter the non sinusoidal voltage and current pattern is filtered and get sinusoidal voltage and current and the output is given to input of shunt and series inverter, the power quality like voltage sag and swell can be compensated and total harmonic distortion can be reduced.

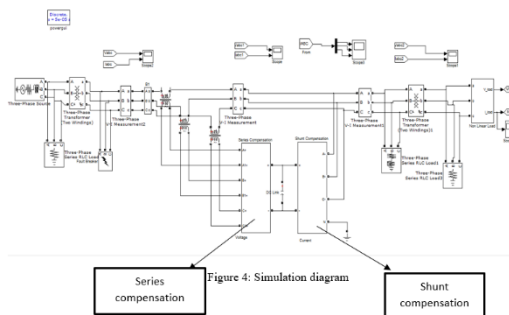

Fig-4: Simulation Diagram

Fig 4 shows that simulation diagram for dual compensation PV fed UPQC

A UPQC has two 5-levels Cascaded Asymmetric Multilevel Converters (CAMC). The CAMC has hybrid multilevel converter characteristics. This converter built as the cascade of two different topologies together with a hybrid modulation strategy. From this reduced number of components and complexity control can be reduced by five voltagelevel. A three phase four leg inverter is been proposed for reactive power compensation.

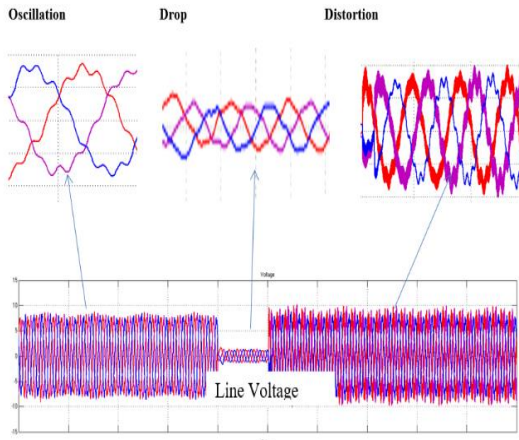

Fig-7: load unbalance in transmission line

fig 7 shows unbalance in transmission line due to nonlinear load. The nonlinear loads on the load side

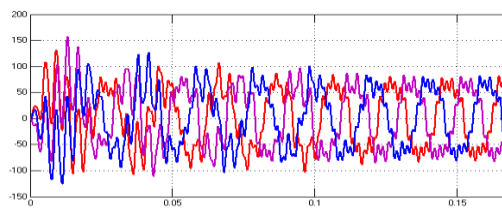

Fig-8 Current imbalance

The figure 8 shows the unbalance in the load current. Due to current imbalance reverse current will flow in transmission line hence generation get affected.

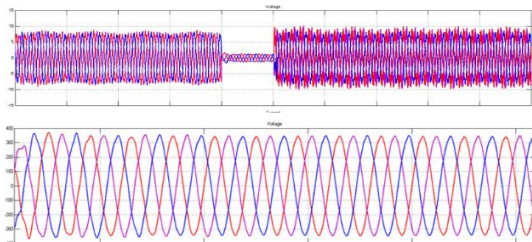

Fig -9: Compensated Voltage

The Figure 9 shows the grid voltage before and after compensation with shunt and series compensator. Due to non linear load voltage gets deviated. By using shunt compensator in PV fed UPQC the voltage is compensated.

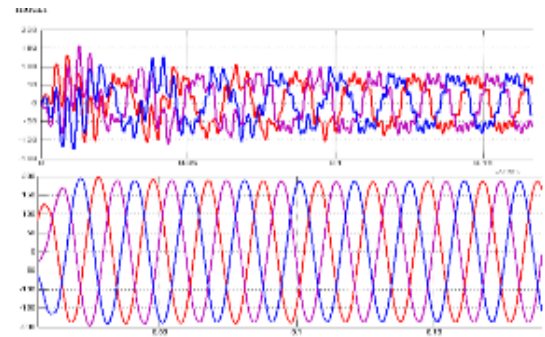

Fig-10: compensated current

Fig 10 shows that before compensation the current is non sinusoidal and By series compensator in PV fed UPQC the current become sinusoidal.

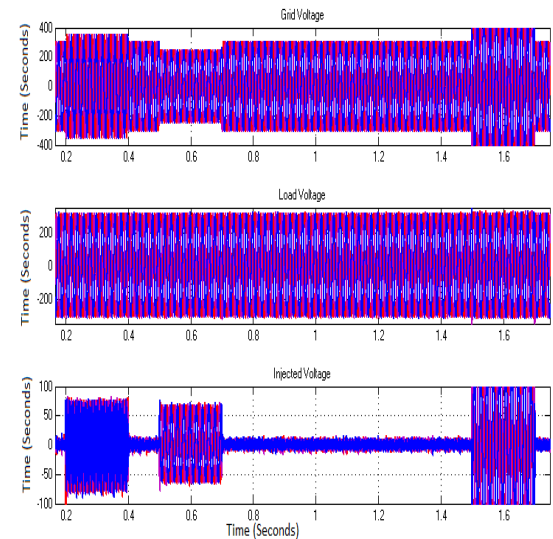

Fig-11: Voltage sag and swell compensation

Fig 11 shows that voltage sag and swell compensation. Voltage sag and swell occur in specific duration in grid side. This voltage can be compensated by injecting voltage from PV array to grid side hence the load voltage can be compensated.

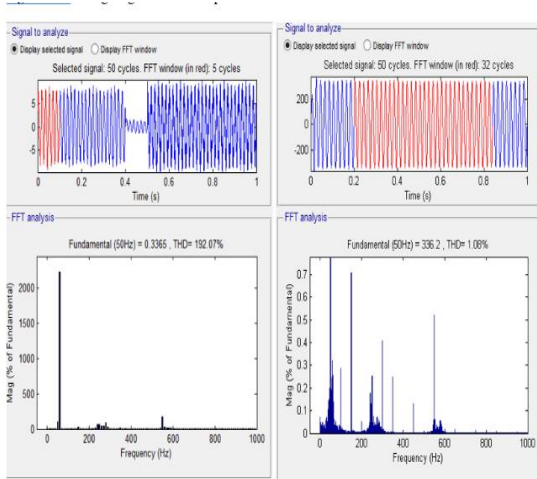

Fig-12: Voltage Harmonics before and after filtering

Figure 12 shows voltage harmonics before and after filtering. Before filtering the THD value is 192.07% and after filtering THD value is 1.08%.

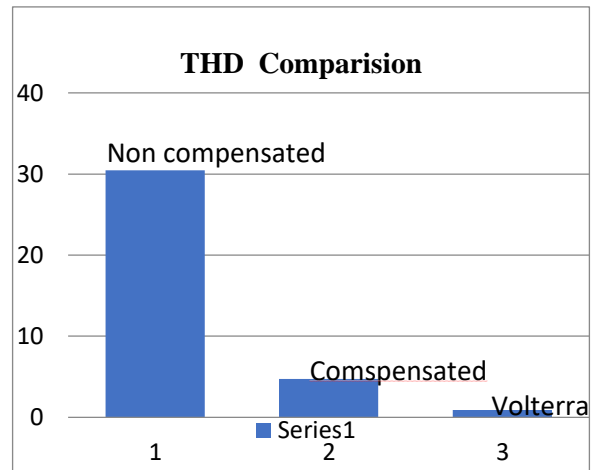

Fig 14- THD comparison

from the fig 14 it shows that before compensation THD value is 30.46% and after compensation THD value is 4.72%. By using Volterra filter after compensation THD value is 0.91%.

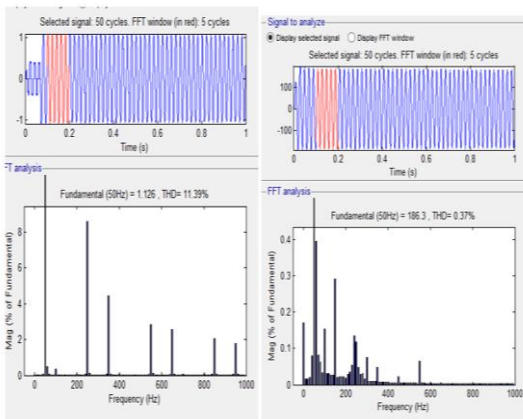

Fig-13: Current harmonics before and after filtering

Figure 13 shows that current harmonics before and after filtering. Before filtering THD value is 11.39% and after filtering THD value is reduced to 0.37%.

5. EXPERIMENTAL SETUP

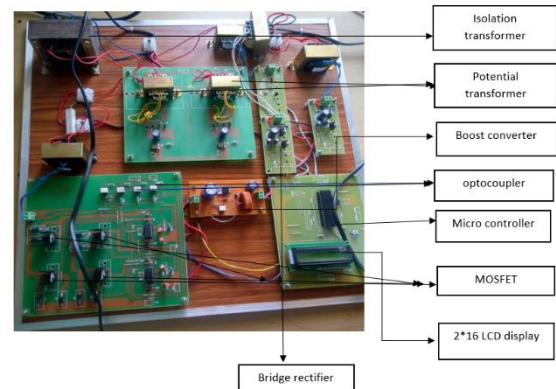

Fig-15: Hardware Prototype

This Hardware is designed with a microcontroller followed by an opt isolator which acts as a isolation between the power circuit and the control circuit, a MOSFETs driver is been connected with a Optocoupler to provide the required switching voltage levels for the MOSFETs circuit. Here we use PIC 16F877A microcontroller for generating PWM signals for the MOSFETs triggering, the microcontroller has a inbuilt timers that are used to generate the PWM signal, an appropriate timer values are been loaded to generate the switch delay, The pic microcontroller works with a +5V supply which is connected to the pins 31, 32 and 11,12 , an

clock frequency of 20MHZ is connected to the microcontroller in the pins 13,14. The opto couplers were operating at +12 V which is provided by external power supply which is obtained using external power supply which is obtained using a voltage regulator. The PWM signals generated to switch the MOSFETs are triggered from the Port B of the microcontroller. The input section of the opto coupler is interfaced to the microcontroller which controls the internal diode and the coupler.

6. CONCLUSION

This work presents the voltage sag and swell compensation based control scheme for power quality improvement in grid connected PV system with non-linear loads. The operation of the UPQC is simulated using dual compensators with Volterra. The reactive has cancelled out and harmonic parts of the generator current and load current has been reduced by UPQC inject current to grid. Dual compensator with Volterra filter compensated both voltage and current. The performance and efficiency of the considered method is studied and the responses are compared with JAYA optimization methods. The proposed system achieved less current harmonics of 0.37% and voltage harmonics of 1.08% than the existing system

REFERENCES

- [1] H. Fujita and H. Akagi, "The unified power quality conditioner: The integration of shunt and series filters," *IEEE Trans on Power Electron*, vol. 13, no. 2, pp. 315-322. Mar.1998.
- [2] S. K. Dash and P. K. Ray, "Platform specific FPGA based hybrid active power filter for power quality enhancement," *Int. J. of Emerging Electric Power Sys*. vol. 18, no. 1, Feb. 2017.
- [3] K. A. Chan dra, A.O. Barry, and T.D. Nguyen, "Power quality enhancement utilizing single-phase unified power quality conditioner: digital signal processor-based experimental validation," *IET Power Electron*. vol. 4, no.3, pp. 323-331, 2011.
- [4] N. D. Tuyen and G. Fujita "PV-active power filter combination supplies power to nonlinear load and compensates utility current," *IEEE Fig. 10. Performance of PV-UPQC under unbalanced voltage sag condition: I*, vol. 2, no. 1, pp. 32- 42, March 2015.
- [5] S. Devassy and B. Shing "Modified p-q theory based control of solar PV integrated UPQC-S," in *Proc. IEEE Industry Application Society Annual Meeting*, Oct. 2016, pp.1-8.
- [6] S. K. Dash, P. K. Ray, S. Mishra, and G. H. Beng, "UPQC-PV solving power quality issues based on system generator FPGA controller," in *Proc. IEEE ICPEICES*, July 2016, pp.1-6.
- [7] M. Kesler and E. Ozdemir, "Synchronous reference frame based control method for UPQC under unbalanced and distorted load conditions," *IEEE Trans. On Inds. Electronics*. vol. 58, no. 9, pp. 3967- 3975, Sep. 2011.
- [8] Y. Pal, A Swarup, and B. Shing, "Performance of UPQC for power quality improvement" in *Proc. IEEE PEDES* . Dec. 2010, pp.1-7.
- [9] Q. N. Trinh and H. H. Lee, "Improvement of unified power quality conditioner performance with enhanced resonant control strategy," *IET Generation, Trans. and Distr*. vol.8, no.12, pp. 2114-2123, 2014.
- [10] B. Subudhi, P. K. Ray, and A. M. Panda, " Parameter estimation technique applied to power networks," in *Proc. IEEE TENCON*, Nov. 2008, pp. 1-5.