

IoT Based Real Time Heart Health Monitoring System

Shreemauli Raut¹, Sahil Vahora², Viren Shah³, Ronak Ranka⁴,

Prof. Mohini Reddy⁵

^{1,2,3,4}Student, Department of Computer Engineering, Mukesh Patel School of Technology Management & Engineering, Maharashtra, India.

⁵Professor, Department of Computer Engineering, Mukesh Patel School of Technology Management & Engineering, Maharashtra, India.

Abstract - Recently, many people have become more enlightened when it comes to heart issues. With the increasing popularity of smart wearable devices and the tremendous advancements in mobile and cloud computing, the opportunity has arisen to offer an IOT (Internet of Things) solution. There is an urgent need to develop an effective heart health monitoring system that can detect abnormal heart condition in a timely manner and send the collected data to a physician. Out-of-hospital survival rates for people with sudden heart attacks and cardiac arrests are unfortunately poor. The aim of this study is to present an intelligent system that uses a custom smart IoT device that can collect cardiac data to give an early warning of a heart abnormalities. The aim is to create an integrated low power smart IoT system to collect heart rates, body temperatures and send important data to a smart mobile device. The use of signal processing for data analysis and an active alarm system are discussed in this study to notify concerned people to take quick action and save valuable time during a crisis.

include coronary artery disease, cerebrovascular disease, rheumatic heart disease and other conditions.

Tachycardia is a condition in which our heart rate is too high. A fast heart rate in adults is described as a heart rate of more than 100 beats per minute (bpm). An underlying health condition such as anaemia, congenital heart disease, heart disease that affects blood flow, hyperthyroidism, heart attack, and so on may cause tachycardia. When our heart rate is too slow, it is called bradycardia. Bradycardia is typically defined as a heart rate that is less than 60 beats per minute. Bradycardia can be caused by an underlying health condition such as: congenital heart disease, damage to the heart (which can be caused by ageing, heart disease, or a heart attack), hypothyroidism, inflammatory diseases (such as lupus or rheumatic fever), myocarditis (an infection of the heart). If the heart rate is too high or too low for an extended period of time, it can lead to a number of potentially serious health complications, including: Blood clots, heart failure, recurrent fainting spells, sudden cardiac arrest.

1. INTRODUCTION

The heart is an important part of the human body. It is located just behind and slightly to the left of the breastbone and size of a fist. The heart pumps blood through a network of arteries and veins known as the cardiovascular system. The number of heartbeats per unit of time is known as heart rate. The left ventricle of the heart beats to supply oxygenated, clean blood to the body's blood vessels through the aorta. Health practitioners use heart rate measurement to aid in the diagnosis and follow-up of a variety of medical conditions, including heart disease. Heart rate is important because the function of the heart is so important. The heart circulates oxygenated and nutrient-rich blood throughout the body.

Heart rate can vary from person to person, but what is considered normal and when is a heart rate considered dangerous? Among all fatal problems, heart disease is considered the most prevalent. Cardiovascular diseases (CVDs) are the number one cause of death worldwide, claiming an estimated 17.9 million lives each year. CVDs are a group of diseases of the heart and blood vessels and

The importance of vital signs stems from the fact that they can be considered as an indicator of a person's health status. Some of the vital signs that are standard in monitoring cardiovascular problems are: Pulse Rate, Respiratory Rate (SpO2 levels), Blood Pressure, Body Temperature, bio-markers.

Unfortunately, a healthy lifestyle is a myth for many due to fast-paced urban living and unavailability of resources in rural areas. Before any of the factors that cause heart attacks reach dangerous levels, the individual is well educated. The Internet of Things will help with this kind of automation (IoT). An IoT platform can be used to measure these vital signs. IoT devices have three building blocks: Cloud computing is often used as an enabling tool for IoT-based systems, allowing a large number of devices and sensors to be connected. Instead of introducing different means for all sensors to communicate directly with one another and, IoT-based healthcare applications may use Cloud Computing systems to enable sensor communication.

It creates a highly distributed network that is efficient and reliable. Buildings, home automation, smart cities, and smart networks all use it. In this paper, an IoT application is proposed that uses a heartbeat sensor and an Arduino board to warn the patient and concerned parties so that appropriate measures and actions can be taken at the appropriate time to save the patient's life. The data collected by the smart device is sent to the doctor for analysis and better treatment. The smart device also has an active alarm system that makes this possible in record time.

Our goal with this project is to create a low-cost smart IoT system that is special and distinct from other e- health related IoT systems for customized cardiac abnormality prediction. The following are our major contributions:

- (i) Creating a smart IoT-based device to predict cardiac abnormalities.
- (ii) Proposing a wearable IoT device-powered heart rate tracking system based on a smart phone.
- (iii) To send data to the smart phone, design, build, and implement a low-power communication module.
- (iv) Implementing an active alert device to detect a unique cardiac crisis.

The remainder of the paper is laid out as follows: The history and relevant related work are described in Section 2.

In Section 3, we go through the problem-solving process for designing our system architecture as well as the circuit design.

In Section 4, we look at how data is collected. The data processing and analysis methods used are discussed in Section 5.

In Section 6, we present the findings of our smartphone-based prototype system's evaluation.

Section 7 concludes the paper with some recommendations for future work and scope. In Section 8, we list our references.

2. LITERATURE SURVEY

Many research efforts are attempting to define a user's cardiac abnormality, but the majority of them are missing main components. Many people are currently studying eHealth, and many businesses have benefited from this research by creating networks that link patients with doctors all over the world. We look at some of the work and talk about the questions it raises.

(i) Heart Attack Detection and Heart Rate Monitoring Using IoT - published in April 2018 focused on implementing a heart rate monitoring and heart attack detection system using the IoT. The patient will wear hardware with sensors and an Android mobile app. The heartbeat sensor will allow the heartbeat readings to be checked and transmitted

over the internet. The hardware consists of Arduino Uno, Node MCU unit and a pulse sensor. The cost and efficiency of the pulse sensor are questionable. Moreover, the data security and usability of the entire module have not been mentioned and also how accurately can a heart attack be measured in terms of metrics or parameters.

(ii) An Efficient Algorithm for Heart Attack Detection using Fuzzy C-means and alert using IOT - published in 2018, this paper gives a brief study on the parameters on which a heart attack depends and the values recommended by a doctor for a healthy body. The paper uses hardware components like Internet of Things (IoT) devices, sensors, board and GSM module. The accuracy model for this is comparatively low because in the field of medicine and science, higher accuracy is required from the model to pass official parameters and metrics.

(iii) IoT: Electrocardiogram (ECG) Monitoring System - This study aimed to develop a small electrocardiogram (ECG) monitoring device that measures heart rates and waveforms and sends the data to a database and web server. An ECG acquisition device was developed using a single- channel heart rate sensor and an Arduino microcontroller. Programs that process analyse and upload the data into MATLAB and process it. The main problem with such a hardware design is portability. Imagine a patient carrying around half-length cables and going to his daily tasks. Not to mention that the cost of such a standalone device is enormous.

To address the shortcomings of the above research and devices, we propose an IoT-based smart heart health system in this paper. Our framework is designed to directly fix some of the shortcomings of existing systems while still providing accurate predictions.

One of the unique features of our system is its abnormal detection of the heart within the record time, which can end up saving the lives of many people.

3. SYSTEM ARCHITECTURE

We use an interface to collect heart rate and body temperature in the smartphone to obtain and analyse data from the IoT system. We created a Wi-Fi communication channel capable of transmitting data from the heart rate and temperature sensors to the smartphone, as defined in the hardware section. The machine analyses the data received from the sensors in order to identify heart rate abnormalities. The application receives data from the sensors automatically after connecting to the IoT computer. The programme divides the temperature and pulse data into separate arrays, which are then sent to various locations for real-time recording and analysis. This project's machine architecture is depicted in Figure 1. The subsections that follow go into the various aspects of this project concept in greater detail.

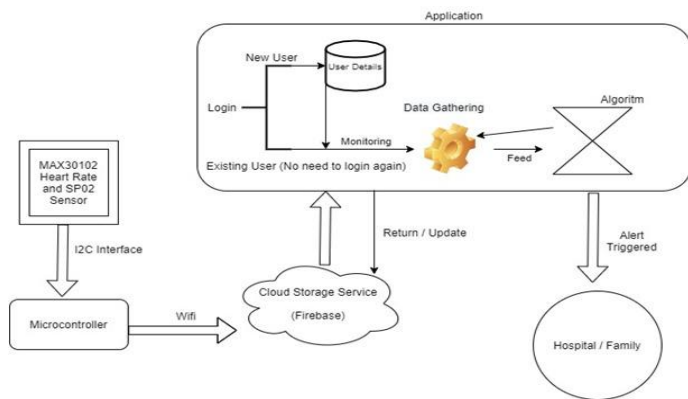

Figure -1: System Architecture

3.1 HARDWARE

The following components sum up the hardware part of this project. They are listed and described below.

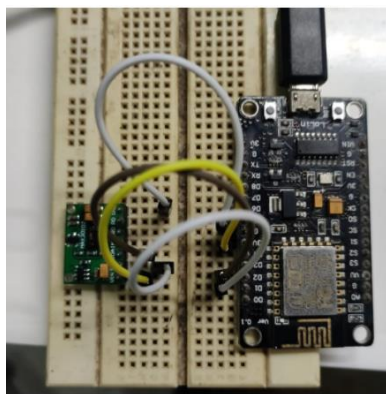

Figure 2. Hardware Module

3.1.1 MAX30102sensor

The MAX30102 is an integrated biosensor module for pulse oximetry and heart rate monitoring. It's made up of red or green LEDs, photo detectors, optical components, and low-noise electronics that ignore ambient light. The MAX30102 is a complete framework that makes the design-in phase for mobile and wearable devices much easier.

The MAX30102 is powered by a single 1.8-V supply and an additional 3.3-V supply for the internal LEDs. A standard I2C-compatible interface is used for communication. The module can be powered down via software without using standby power, ensuring that the power rails are still active.

The MAX30102 uses a method called photo plethysmography to measure a person's heart rate. This method involves shining light on the skin and measuring the blood flow. One of the practical aspects of this

approach is that it is possible to distinguish between light reflected from the blood of an artery (producing a AC output) and other components of the body such as bone and tissue (producing a DC output). The photodiode in the sensor then converts the light into current, which we can use as intelligible data.

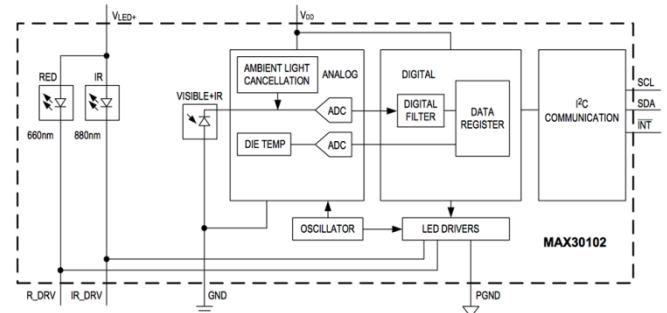

Figure 3. Max30102 sensor

3.1.2 ESP8266-12E

The ESP-12E is a small Wi-Fi module that can be found on the market and is used to link a microcontroller or processor to a wireless network. The ESP8266EX, a highly integrated wireless SoC, is at the heart of the ESP -12E. (System on Chip). It can be used to integrate Wi-Fi capabilities into applications or as a stand-alone programme. It is a cost-effective approach for developing IoT applications.

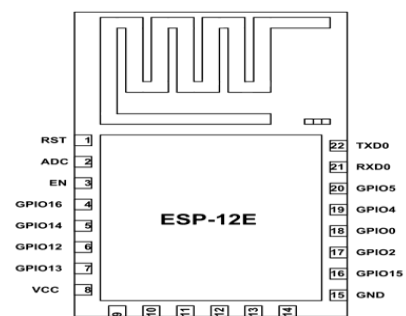

Figure 4. ESP-12E Module

3.1.3 OLED DISPLAY

OLED (Organic Light Emitting Diodes) is a flat light-emitting technology made by sandwiching a series of organic thin films between two conductors. When electric current is applied, a bright light is emitted. OLEDs are emissive displays that do not require a backlight and are therefore thinner and more efficient than LCD displays, which require a white backlight. OLED screens are not only lightweight and energy efficient, but they also have

the highest image quality ever and can be rendered translucent, flexible, foldable, rollable, and stretchable in the future. OLEDs are the display technology of the future.

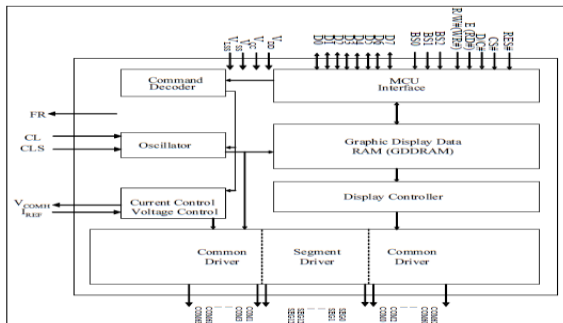

Figure 5. OLED display

3.1.4 POWER SUPPLY 5V

The power supply of 5V and 25-30mA current is used in this module to power the IoT device. The use of portable Lithium batteries and an adhesive or cover will be used to attach the battery to the smart device. The service life of a typical battery lasts around 350 to 500 recharges which makes it perfect for the smart IoT module.

3.2 SOFTWARE

3.2.1 ARDUINO IDE:

The Arduino Integrated Development Environment (IDE) is a cross-platform application (for Windows, MacOS, Linux) written in functions of C and C++. It is used to write code into Arduino friendly boards. IDE provides many common input and output methods. For user-written code, only two basic functions are required, to start the sketch and the main program loop, which are compiled and linked to an executable program with a program stub main().

3.2.2 ANDROID STUDIO:

Android Studio is an IDE (tool) for developing your Android app. It automatically simplifies and generates java files, directories (folders), placeholder icons, manifest file, XML files and many other things. Android Studio is used to create the user interface and connect Firebase to get the real-time data.

4. DATA ACQUISITION

The user first puts on the computer as described in the preceding sections, then connects to the Wi-Fi interface using the Android application as described in the Software section. From this point forward, the user can only interact

with the application, which will allow them to navigate through the different options available.

We started testing on test subjects after we finished the method and made sure it was correct. Since we couldn't test our system on real people with chronic heart disease, we gathered a group of people of various ages and sizes. The data gathering process is divided into two parts: data collection from the IoT system and data transmission to the smartphone application. The heart's pulse rate and blood oxygen level are measured by a sensor in the first section.

Our proposed system collects user data and stores it in a database, as well as displaying and processing it in real time. We had to gather data from ten different subjects in order to write our algorithm. We present data from ten sedentary subjects, five male and five females, in this segment. We were unable to obtain data for the treadmill walking scenario and stair ascending with stairs or steppers due to the inability of certain patients to do so. For each scenario, we were able to collect heart rate and blood oxygen levels from the patients to ensure that the method was accurate

Test Patients Information					
Gender	Weight(kgs)	Height(cm)	Age(yrs)	Heart Rate	Spo2 Level
Male	65	173	22	102	97
Male	85	181	21	89	99
Male	75	175	23	94	99
Female	62	169	29	85	98
Female	69	173	32	105	95
Male	80	185	42	111	95
Male	55	176	27	80	99
Female	59	165	32	95	96
Female	45	162	15	84	98
Female	76	178	55	105	95

Table 1. Test Patient Information

[5]. Table 1 above shows the information of the ten subjects. These subjects are divided equally based on gender and have a range of age amongst them.

5. DATA ANALYSIS TECHNIQUE

Noise is a general term for unwanted changes that a signal may experience during the collection, storage, transmission, or processing of data in the processing of certain signals. Data from sensors was collected and transmitted through a low-power Bluetooth

communication channel. Since the readings can be distorted by noise during the process, we need to use data cleaning and enhancement techniques before we can begin analysing the data.

Filtering is a technique for reducing noise. When features are extracted from a noisy signal, the result could be a heart rate of 200 when the real heart rate is 80. As a result, we ensure that almost all unnecessary parts of the signal are removed before sending it to the function extraction process. A high pass filter on the signal enhances the signal by suppressing the baseline wander. This will allow us to process the data more precisely.

For each sampling window, the feature extraction function returns a single value for the heart rate, in a one-dimensional array containing the RR interval durations, and a one-dimensional array containing the ST segment voltage values. Since heart rate is the most important feature describing the state of the heart, we first examine the variations in heartbeats.

To do this, we use our standard deviation analysis to make sure the heart rate stays the same Walking or running causes the heart rate to automatically rise faster than sitting or sleeping. We couldn't actually use a threshold technique where a heart rate above a certain threshold will be a sign of potential heart failure since we have such a wide variety of heart rates that are considered natural. Heart rates can range from 55 to 150 depending on the individual and the activity they are currently engaged in. An issue with heart rate is only detected when it unexpectedly fluctuates outside of the normal range. We set the alert level to 1 if the current heart rate has an error of more than 7 to 17 percent. For instance, if a person's average heart rate fluctuates between 80 and 100 beats per minute for 20 seconds before suddenly increasing to 100, the error is 25%. If there is an issue with the current heart rate, we just check the RR intervals. If the RR interval error is greater than a percentage, the alert level is set to 2 and the ST section is examined. If the ST segment also has a higher error than what we consider natural or predefined, we raise the alert level to 3 and check the body temperature. We'll keep checking the body temperature to see if the alert level rises to 4, as it may be a false reading due to feature extraction errors caused by noisy signals up to this stage. We measure the error in the same way we do for heart rate since temperature is a single value, but with different thresholds. We then process this alert and read the next sample window by returning the warning level for each sample window.

5.1 ALGORITHM

- 1) Initialize Serial communication
- 2) Set Baud Rate at 115200
- 3) Perform I2C Communication between MAX30102

sensor & esp8266

- 4) Connect to the specified network with the given ssid and password.
- 5) Use Serial Data and Serial Clock to properly synchronize the data between both the modules.
- 6) Perform a regular check at on every second for beat detection
- 7) Set a Timer Interrupt at 2 second interval to send the data to Cloud.
- 8) Multiply the Raw vital sign by 60 to give the appropriate heart rate
- 9) Calculate the SpO2 sign value using the infrared value of the sensor
- 10) Send the data to firebase cloud service (Realtime Database) as soon as the timer interrupt is fired.
- 11) Perform an averaging over 4000 data values to give a smooth result
- 12) Repeat Step 7 to 11 till the sensor is not stopped/power supply is disconnected
- 13) End

5.2 Calculation Method for Heart Rate

- 1) Start
 - 2) Use default I2C port at 400KHz
 - 3) Read the IR value from the MAX30102 module
 - 4) 4-lastbeat=0
- ```
rate_size = 4000
```
- 5) 5-if (IR\_value <10000){ Finger\_not\_detected }
- ```
else{
```
- ```
Finger_detected
```
- ```
}
```
- 6) 6- delta = millis()-lastbeat
 - 7) bpm = 60 / (delta/1000.0)
 - 8) beat_avg = beat_avg / rate_size
 - 9) 7- Repeat step 5&6 continuously in loop to get constant readings
 - 10) 8- Stop

5.2 Calculation Method for SpO2 Blood Oxygen levels

- 1) Start
- 2) Initialize both red & infrared led for SpO2 detection
- 3) begin I2C communication
- 4) sample_rate = 100
sample_average = 4
adcRange = 4096
- 5) Take first 100 samples for sampling the data, dump first 25 sets in the memory and then the last 75 sets to the top
- 6) Get ir value and deduce SpO2 level every 1 second
- 7) Get ratio between ac component of IR&Red led and the DC component of IR&Red led to get SpO2
- 8) use peak detector as valley detector

9) Stop

6. RESULT ANALYSIS

6.1 HEART RATE ANALYSIS

HEART RATE ANALYSIS					
Test Subject	Weight(kgs)	Height(cm)	Age(yrs)	Scenario	Heart Rate
Subject 1 (Male)	65	173	22	i) Sitting ii) Walking iii) Climbing	i) 107 ii) 110 iii) 134
Subject 2 (Male)	85	181	21	i) Sitting ii) Walking iii) Climbing	i) 73 ii) 98 iii) 117
Subject 3 (Male)	75	175	23	i) Sitting ii) Walking iii) Climbing	i) 95 ii) N/A iii) N/A
Subject 4 (Female)	62	169	29	i) Sitting ii) Walking iii) Climbing	i) 85 ii) 97 iii) 136
Subject 5 (Female)	69	173	32	i) Sitting ii) Walking iii) Climbing	i) 105 ii) 119 iii) N/A
Subject 6 (Male)	80	185	42	i) Sitting ii) Walking iii) Climbing	i) 111 ii) 105 iii) 120
Subject 7 (Male)	55	176	27	i) Sitting ii) Walking iii) Climbing	i) 80 ii) 88 iii) 110
Subject 8 (Female)	59	165	32	i) Sitting ii) Walking iii) Climbing	i) 95 ii) 96 iii) 102
Subject 9 (Female)	45	162	15	i) Sitting ii) Walking iii) Climbing	i) 84 ii) N/A iii) 125
Subject 10 (Female)	76	178	55	i) Sitting ii) Walking iii) Climbing	i) 105 ii) 119 iii) N/A

Table 2. Heart Rate Analysis

6.1.1 INFERENCES

Subject 1's data was found to be error-free while he was sitting and walking. For all vitals, the normal value for heart rate is shown. Variations occurred as the data collected fluctuated due to the subject's need to ascend. The values here are higher than expected as the subject was moving causing more pumping of blood. This is due to the sensor shifting while the subject was engaged in various activities. In all three cases, we collected data for subjects 2 and 5, and the results were as predicted. The data for subject 3 was poor as there were some challenges during this process. One of them was that the finger was not in the best condition as it had lubricant on it as some point in time. We could capture data of subject 3 while sitting but other scenario data was not available. Overall subject 3 looked satisfactory and had no history of heart problems. The data for subject 4 was entirely captured

and as we can see in Table 2 above the Sitting and walking data of the subject was completely normal but Climbing data was higher than expected as the heart was working constantly pumping rich blood in the subject's body during this activity. The data for subject 5 for scenarios Sitting and Walking was captured and classified as normal but for Climbing the data was not available as the subject had skinny fingers and the sensor kept shifting in motion. The data for subjects 6, 7, 8 was collected without any hindrance for all 3 scenarios. The data for subject 9 was collected for sitting and walking but for walking the data was unavailable as the sensor kept moving and was unstable for collection. For subject 10 the data for 2

6.2 SPO2 ANALYSIS

SpO2 LEVEL ANALYSIS					
Test Subject	Weight(kgs)	Height(cm)	Age(yrs)	Scenario	SpO2 Level
Subject 1 (Male)	65	173	22	i) Sitting ii) Walking iii) Climbing	i) 96 ii) 98 iii) N/A
Subject 2 (Male)	85	181	21	i) Sitting ii) Walking iii) Climbing	i) 94 ii) 94 iii) 96
Subject 3 (Male)	75	175	23	i) Sitting ii) Walking iii) Climbing	i) 99 ii) 98 iii) 98
Subject 4 (Female)	62	169	29	i) Sitting ii) Walking iii) Climbing	i) 98 ii) 99 iii) 99
Subject 5 (Female)	69	173	32	i) Sitting ii) Walking iii) Climbing	i) 95 ii) N/A iii) 97
Subject 6 (Male)	80	185	42	i) Sitting ii) Walking iii) Climbing	i) 95 ii) 98 iii) 99
Subject 7 (Male)	55	176	27	i) Sitting ii) Walking iii) Climbing	i) 99 ii) 98 iii) 99
Subject 8 (Female)	59	165	32	i) Sitting ii) Walking iii) Climbing	i) 96 ii) 96 iii) 95
Subject 9 (Female)	45	162	15	i) Sitting ii) Walking iii) Climbing	i) 98 ii) N/A iii) 98
Subject 10 (Female)	76	178	55	i) Sitting ii) Walking iii) Climbing	i) 95 ii) 96 iii) N/A

Table 3. SpO2 Level Analysis

6.2.1 INFERENCES

The data obtained for subject 1 while sitting and walking was found to be error-free. All vitals for blood oxygen show the standard value. Data for climbing scenario is not available as value was inconsistent. Similarly, for subject 2 the values here are slightly lower than expected as the subject was not moving causing less pumping of blood. Similarly, we collected data for subject 3,4 and 6 in all three scenarios and the results were normal and as expected. Specifically, the data for subjects 3 and 4 was rich. Overall subject 5 looked satisfactory and had no history of heart problems. The data for subject 5 while walking was not captured as sensor was not properly fitted. The data for subject 7 was entirely captured and as we can see in Table 3 above the Sitting and walking data of the subject was completely normal but Climbing data was higher than expected as the heart was working constantly pumping rich blood in the subject's body during this activity. The data for subject 8 was collected without any hindrance for all 3 scenarios. The data for subject 9 was collected for sitting and climbing but for walking the data was unavailable as the sensor kept moving and was unstable for collection the data for Subject 10 for scenarios Sitting and Walking was captured and classified as normal but for Climbing the data was not available as the subject had lubricated fingers and the sensor kept shifting in motion.

7. CONCLUSION

We created and designed a smart IoT device for predicting and tracking cardiac abnormalities in patients in this paper. We were also able to establish a low-power communication link between the smart IoT system and the smartphone app. This study develops a non-invasive system that allows users to better understand their heart vitals. Results from various datasets are also presented, showing that this approach provides high classification accuracy in distinguishing between normal and abnormal heart vital patterns. To test the temporal consistency and long-term feasibility of our approach in the future, we plan to test our system with data from people suffering from heart problems. We plan to get datasets from hospitals and coordinate with top doctors in the cardiac space to help us out with filtering information that is important. During a preliminary test, we want to assess the power consumption rate over the device's lifespan. We also plan to monitor the user's physiological parameters as they go about their everyday lives. Together with the Heart Rate and the blood oxygen meter, we have developed an Application that allows medical professionals and patients to communicate with one another, record data from a heart monitor over Wi-Fi, and access these records by the doctor.

8. FUTURE WORK

Additional improvements can be made to this project to improve its performance Design of a compact device to increase measurement performance even though unfiltered noise is present. Also, suggest a new method for transferring data between the Microcontroller and the Android application that is more effective. Further tests for a greater number of people with various demographic profiles can be performed to ensure the accuracy of the heart rate unit. Conducting beta tests for an Android application. To improve the device's accuracy and functionality, add a temperature sensor for body measurement and biomarkers. Incorporate a blood pressure monitor into our machine, which will be both compact and informative. To improve the project's importance to patients, more vital signs should be added. This may involve things like blood pressure, biomarkers, and respiratory data, among other things. When a heart abnormality is detected and the alarm is turned on, the MCU can send a control signal along with the measured data. The control signal should trigger GPS and instruct the application to send an SMS containing the calculated data and the patient's location to the patient's emergency medical personnel and emergency contacts, instructing them to summon an ambulance and alert their concerned family members. The system could be miniaturized into a printed circuit board in order to minimize weight and make it commercially available for public use. The system requires a portable and compact battery unit to provide the required power for the sensors and MCU.

9. REFERENCES

- [1] ETSI, F., & Orange, F. Internet of Things Global Standardisation-State of Play
- [2] Vermesan, O., & Friess, P. (Eds.). (2013). Internet of things: converging technologies for smart environments and integrated ecosystems. River publishers.
- [3] Clarke, R. Y. (2013). Smart cities and the internet of everything: The foundation for delivering next-generation citizen services. Alexandria, VA, Tech. Rep.
- [4] Evans, D. (2011). The internet of things: How the next evolution of the internet is changing everything. CISCO white paper, 1(2011), 1-11.
- [5] Logvinov, O., Kraemer, B., Adams, C., Heiles, J., Stuebing, G., Nielsen, M. L., & Mancuso, B. (2016). Standard for an architectural framework for the internet of things (iot) ieee p2413. Tech. Rep. September.

- [6] IEEE Standards Association, & IEEE Standards Association. (2015). Internet of Things (IoT) Ecosystem Study. IEEE Standards Association, The Institute of Electrical and Electronic Engineers, Inc.
- [7] Deering, S., & Hinden, R. (1998). Internet protocol, version 6 (IPv6) specification.
- [8] Djamaa, B., & Witty, R. (2013, October). An efficient service discovery protocol for 6LoWPANs. In 2013 Science and Information Conference (pp. 645-652). IEEE.
- [9] <https://www.sparkfun.com/products/12576>.
- [10] <https://robotechshop.com/shop/arduino/arduino-board/arduinouno-r3-china?v=7516fd43adaa>.
- [11] <https://www.sparkfun.com/products/11574>.
- [12] ETSI, F., & Orange, F. Internet of Things Global Standardisation-State of Play.
- [13] Vermesan, O., & Friess, P. (Eds.). (2013). Internet of things: converging technologies for smart environments and integrated ecosystems. River publishers.
- [14] Clarke, R. Y. (2013). Smart cities and the internet of everything: The foundation for delivering next-generation citizen services. Alexandria, VA, Tech. Rep.
- [15] Evans, D. (2011). The internet of things: How the next evolution of the internet is changing everything. CISCO white paper, 1(2011), 1-11.
- [16] Sani, N. M., Mansor, W., Lee, K. Y., Zainudin, N. A., & Mahrim, S. A. (2015, May). Determination of heart rate from photoplethysmogram using Fast Fourier Transform. In 2015 International Conference on BioSignal Analysis, Processing and Systems (ICBAPS) (pp. 168-170). IEEE.
- [17] Patel, N., Patel, P., & Patel, N. (2018). Heart attack detection and heart rate monitoring using IoT. International Journal of Innovations and Advancements in Computer Science, IJIACS, 7(4), 612-615.
- [18] Ortiz, K. J. P., Davalos, J. P. O., Eusebio, E. S., & Tucay, D. M. (2018). IoT: Electrocardiogram (ECG) monitoring system. Indonesian Journal of Electrical Engineering and Computer Science, 10(2), 480-48

10. BIOGRAPHIES



Shreemauli S. Raut, Student of Mukesh Patel School of Technology and Management, pursuing bachelor's degree in Computer Engineering from NMIMS university.



Sahil A. Vahora, Student of Mukesh Patel School of Technology and Management, pursuing bachelor's degree in Computer Engineering from NMIMS university.



Viren V. Shah, Student of Mukesh Patel School of Technology and Management, pursuing bachelor's degree in Computer Engineering from NMIMS university.



Ronak Ranka, Student of Mukesh Patel School of Technology and Management, pursuing bachelor's degree in Computer Engineering from NMIMS university.



Prof. Mohini Reddy, Department of Computer Engineering at Mukesh Patel School of Technology and Management.