

Covid19 Health Monitoring System

Vinay Kumar¹, Vikas Meena², Vishal Kumar³, Prof. J.N. Rai

¹B. Tech Delhi Technological University, Shahbad Daulatpur, Delhi-110042

²B. Tech Delhi Technological University, Shahbad Daulatpur, Delhi-110042

³B. Tech Delhi Technological University, Shahbad Daulatpur, Delhi-110042

⁴Professor, Dept. of Electrical Engg. Delhi Technological University, Shahbad Daulatpur, Delhi-110042, India

Abstract – Covid-19 health monitoring system is developed in this paper. The model consists of Temperature measurement, social distancing using the ultrasonic sensor, and heartbeat measurement. Temperature sensors measure body temperature using the LM35 sensor and Arduino, it works on the principle of resistor sensitivity of temperature. One of the symptoms of covid-19 is a rise in body temperature, which is an early symptom and can be measured with the help of a temperature sensor. An infrared sensor measures the heartbeat. Since covid-19 spread among people who are in close contact with each other, hence maintaining social distancing is a very important factor. In an ultrasonic sensor, if something comes within the range of 30cm of the sensor a buzzer sounds, therefore it tells someone is within social distancing range.

Key Words: Arduino, COVID 19, Infrared sensor, digital Thermometer, social distancing, heart rate.

1. INTRODUCTION

Corona is an infectious disease that has killed so many people around the world. This virus is also called SEVERE ACUTE RESPIRATORY SYNDROME (SARS-COV-2) [2]. It infects the respiratory system. When somebody comes infected with the virus it builds an immune response, this immune response causes inflammation that inflammation can lead to cough which produces droplets into the air. Other people can get those droplets and get infected [1]. It can also lead to fever, as it progresses some people's immune systems can knock the virus out and these people are going to do well, we have seen that. Other times however the virus sets in into the lungs, which leads to the problem with oxygenation, which means we can't get proper oxygen from the air [1]. That's why we need to monitor our heart rate and body temperature. By recording these measurements, we can decide the best treatment for us. An infrared sensor monitors how fast our heartbeats. The best way to prevent the transmission is early detection of the covid-19 patient and maintaining social distancing [2]. For the most covid-19 patient, a rise in body temperature and an increase in a heartbeat are early symptoms. LM-35 temperature sensor Ultrasonic sensor and Infrared sensor are used with Arduino. There is a switch provided which makes this model to work in two modes in the first mode it can be used as a social distancing maintenance device that starts producing a buzzing sound whenever the distance between the sensor and object is less than 30 cm. In its second mode, it measures the temperature and heartbeat of our body for 30 seconds

and displays it on an LCD screen. Our health monitoring system can easily detect those early symptoms and it is easy to use and manufactured at low cost and it can be used in homes, schools, and offices, etc.

2. TEMPERATURE MEASUREMENT

One of the early symptoms of the covid 19 is high fever, fever can also be due to the normal cold but we cannot deny the fact that covid 19 is more lethal than the common cold,[6] high temperature in the body can be taken as precautionary measures for covid-19. We have used LM35 with Arduino to measure the body temperature and printing its value on the LED screen [3]. This sensor is an analog-based linear measuring device, it changes the output positively by 1 degree Celsius in temperature when there is a 10mV change in voltage [7]. Its functioning can be described in 3 parts (1) LM35 senses the temperature (2) it converts temperature into suitable voltage (3) voltage is converted into specific value and displayed on LCD. A time interval of 30 seconds is provided for the sensor to sense the body temperature so that accurate temperature can be measured with minimum error.

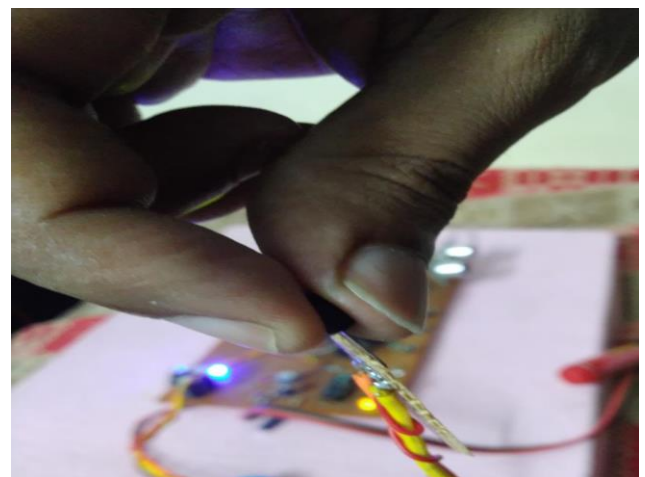

Fig1.- Measuring Temperature



Fig2.- Temperature reading in degree Celsius

S.NO	NAME	TEMPERATURE (°C)
1	Rahul	30
2	Priya	32
3	Ketan	31
4	Anand	32
5	Anil	35

Table 1. Temperature measurement of different people

We have measured the body temperature of five different people as shown in the above table. The chances of having corona in these people are less because their body temperature is less than 38°C

3. SOCIAL DISTANCE ALERT SYSTEM

Social distancing using ultrasonic sensor HCSR04 [3],[4]. In the covid situation maintaining social distancing is the best practice for prevention, HCSR04 is used as a proximity sensor. Ultrasonic sensor uses ultrasonic sound waves to measure the distance. By the given formula

$$D = \frac{1}{2} T * C \text{ [11]}$$

T= total time between wave is reflected and collected back at receiver end.

$$C = 343 \text{ m/s}$$

HCSR04 is used with buzzer that starts buzzing when the distance is less than 30cm

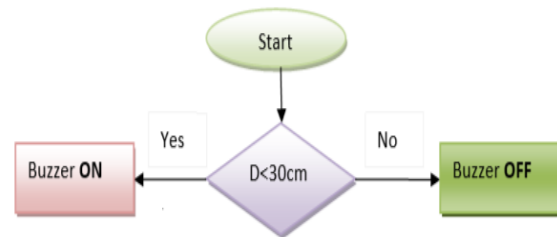

Fig3. - Flow chart

Darlington pair [12] is used with the buzzer to enhance its sound, due to the high current gain of the Darlington pair buzzer sound is clearly audible to a longer distance [10]. Darlington pair circuit causes the disk inside the buzzer to vibrate with greater force ultimately leads to a higher voice than normal.

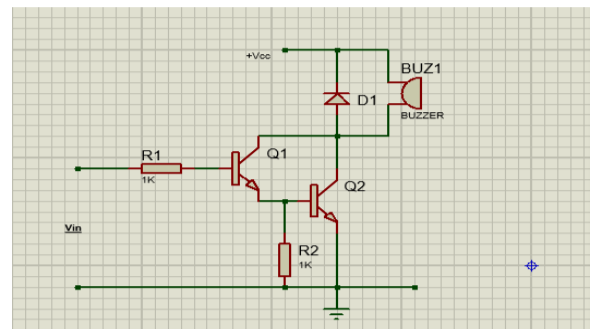

Fig4.-Schematic of Buzzer with Darlington pair

There are numerous applications if we talk in Indian context like this device can be used at Indian store counters to maintain proper social distancing between a cashier and the customer [5].



Fig5.- HCSR04 (ultrasonic) sensor and Buzzer

4. HEART RATE MEASUREMENT

Heart rate is also affected if a person is suffering from Covid 19, and later stage as seen in covid patients it affects the whole respiratory system. So, an increase in heart rate is also an early symptom of Covid-19. We have used an Infrared sensor to measure the heartbeat. It measures the heart beat

reflecting infrared light from human tissue. The Sensor measures the variations happening in blood volume in tissues. When we place the finger on the sensor it transmits the infrared light into tissue and the transmitter measures the reflected rays [8]. BPM is the number of times when the heart beats every minute, 1 minute is a long time for the measurement, nowadays we have some devices like a pulse oximeter that can measure heartrate within 2-3 seconds. We have designed the circuit in such a manner that it measures the heartrate for 30 seconds and the final reading is then multiplied with the factor of 2 because 1 minute has two 30 seconds in it. After that reading is shown on an LED [9]. Everyone has little uniqueness in their dimensions of fingers so there should be some adjustments (sensitivity level) to be done so that we can get proper readings.

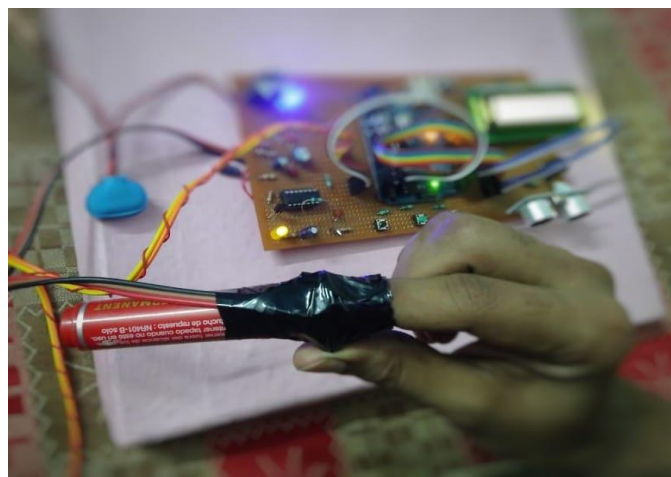

Fig6.- Measuring heartbeat

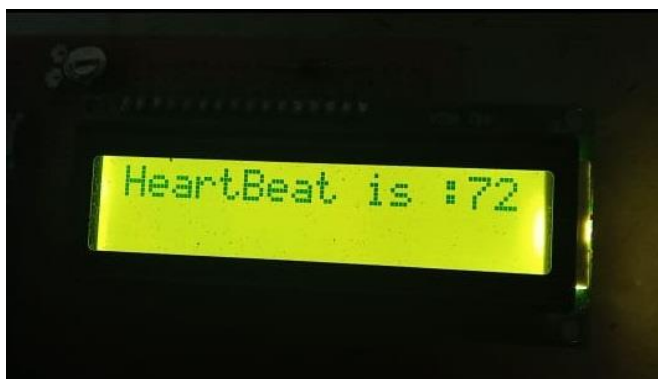

Fig7.- Heartbeat reading

S.NO	NAME	BPM
1	Rahul	88
2	Priya	94
3	Ketan	82
4	Anand	86
5	Anil	92

Table 2. Heartbeat measurement of different people

We have measured the heartbeat of five different people as shown in the above table. The chances of having corona in these people is less because their heart beat per minute is between 72-120 which is considered as normal.

5. CONCLUSION

This paper aims to provide a health monitoring system for various Citizens to monitor their health and do preliminary covid-19 test in their home and workplace. The unfavorable readings of this monitoring system must not be used as a final indicator of the positive covid'19 test, but this system can be used as an early indicator to visit for a covid'19 test in the nearest hospital. This system can be used in homes, offices, shops, and various public places. However, the proper use of device instructions is required to maximize the accuracy of the Health monitoring system. Further innovation in this project will not only increase its accuracy but also able make it more compact and efficient.

REFERENCES

[1] Dalha, S., & Babangida, I. (2020). Immune Response To Covid-19 Infection. COVID-19 Pandemic Update 2020, 108-127. doi:10.26524/royal.37.9

[2] Sohrabi, C., et al., World Health Organization declares global emergency: A review of the 2019 novel coronavirus (COVID-19). International Journal of Surgery, 2020

[3] Y. Yurish, "Non-Contact, Short Distance Measuring System for Wide Applications," 19th IMEKO World Congress, Fundamental and Applied Metrology, Lisbon, Portugal, 6-11 September 2009, pp. 643-647.

[4] <https://www.cdc.gov/coronavirus/2019-ncov/prevent-getting-sick/socialdistancing.html#:~:text=Since%20people%20can%20spread%20the,severe%20illness%20from%20COVID-19>

[5] Organization, W.H., Rational use of personal protective equipment for coronavirus disease (COVID-19): interim guidance, 27 February 2020. 2020, World Health Organization.

[6] H. Mansor, M. H. A. Shukor, S. S. Meskam, N. Q. A. M. Rusli and N. S. Zamery, "Body temperature measurement for remote health monitoring system," Smart Instrumentation, Measurement and Applications (ICSIMA), 2013 IEEE International Conference on, Kuala Lumpur, 2013, pp. 1-5

[7] Michael McRoberts "Beginning Arduino", technology in action, second edition, ch-13, pg - 271-277

[8] Sagar C. Chhatrala, 2Mitul R. Khandhedhia" Ubiquitous Physiological Monitoring of SPO2& Heart Rate" International Journal for Research in Technological Studies Vol. 1, Issue 2, January 2014

[9] Hashem et al., –Design and Development of a Heart Rate Measuring Device using Fingertip||, IEEE International Conference on Computer and Communication Engineering (ICCCCE), ISBN: 978-1- 4244-6235-3, 2010.

[10] Duval, “Advances in Analog Distance Sensing”, Sensor Measurement, September 2004

[11] Texas Instruments "ultrasonic sensing Basics - application report SLAA907C–September 2019–Revised March 2020" pp-2

[12] "Analysis and design of analog Integrated circuits" fourth edition - Gray Hurst Lewis Meyer pp-202,205