

Suspension based power generation for EV Range improvement

Dattu B. Jagdale¹, Yogesh K. Chavan², Akash R. Gaikwad³, Vikas B. Gaikwad⁴, P.S. Baravkar⁵

^{1,2,3,4} BE Student, Department Of Mechanical Engineering, SND COE & RC, Yeola, Maharashtra, India

⁵ Professor, Department Of Mechanical Engineering, SND COE & RC, Yeola, Maharashtra, India

Abstract - The power generator electromagnetic suspension system is a system that converts vehicle bump generated linear motion & vibration, into electricity to be used in battery charging. General vehicle shock absorbers are used to simply absorb this energy without converting it to electricity. So here we put forth a way to use this free energy and store it for further needs such as vehicle lights, cooling, indicator lights etc. To achieve this we here use the principles of electromagnetism in order to generate electricity from this motion. Our shock absorber is made up of a metal shaft, spring, magnet, coils, base with screws and joints. It uses a coil wound around in particular turning arrangement over the inner beam of the part. We use cylindrical supports in order to minimize friction and ensure smooth generation. The head of the absorber consists of magnets attached to outer core which are aligned with inner core to ensure smooth motion while ensuring efficient generation. This arrangement is fitted with springs in a precise manner so as to achieve the desired motion and magnet coil overlapping which allows for generation of electricity through electromagnetism principle. Thus our system puts forward a smart power generation system using electromagnetic suspension system.

Key Words: EV, NF, Regenerative suspension, Linear Generator, Capacitor Charge Recovery Bank.

1. Introduction

The main objective of designed the controller for a vehicle suspension system is to reduce the discomfort sensed by passengers which arises from road roughness and to increase the ride handling associated with the pitching and rolling movements. This necessitates a very fast and accurate controller to meet as much control objectives, as possible. Therefore, this paper deals with an artificial intelligence Neuro-Fuzzy (NF) technique to design a robust controller to meet the control objectives. The advantage of this controller is that it can handle the nonlinearities faster than other conventional controllers. The approach of the proposed controller is to minimize the vibrations on each corner of vehicle by supplying control forces to suspension system when travelling on rough road. The other purpose for using the NF controller for vehicle model is to reduce the body inclinations that are made during intensive maneuver's including braking and cornering. A full vehicle nonlinear active suspension system is introduced and tested. The results show that the intelligent NF controller has improved the dynamic response measured by decreasing the cost function.

It was described to develop electricity using the real-time motion of parts in a form of wheeler. After careful analysis of a various such parts it was decided to generated electricity using relational motion available in a suspension system of a two wheeler. In the new age of the electric bikes, almost everything has to be modified. In one hundred years, people will launch at today's hybrid and pure electric vehicles rather in the way we launch at motor vehicles from 1880 that looked like something dragged along by a horse because that was the starting point. Inside and out, today's electric vehicles look almost the same as what went before. We have batteries and electrical and electronic controls in big lumps because that is what they had to look like in the past, together with masses of wiring. We have a big lump of noisy, dirty, shaking internal combustion engine in a hybrid because that is what an engine has looked like in the past. Bring in smart electronic surfaces, wireless links, laminar conformal batteries and mini turbine range extenders. Then we really will have moved on in cost, performance and passenger safety, comfort and space available. However, until we figure out how to make comfortable vehicle bodies we shall need shock absorbers, so they might as well generate electricity.

1.1 Selection of Project

We the group of young engineers found that, there is an impending need to make much more forays to make Non-Conventional energy attain popular acclaim. This is also very essential to preserve the conventional sources of energy and explore viable alternatives like sustainable energy (the energy which we are already utilizing but for some safety of other uses we are suddenly wasting it, that can be reutilized), solar, wind and biomass that can enhance sustainable growth. What is more, such alternatives are environment friendly and easily replenish able. Therefore, they need to be thoroughly exploited with a functionally expedient, energy matrix mix. Growing economies, especially of Asia are gifted with sufficient resource base and non-conventional energy technologies are consistent both for grid linked energy generation and transmission in out of the way locales that are islanded from the grid.

Adaptation of technology and employing them should be pursued right from this moment to have a head start, be informed of the barriers in technology applications of the renewable variety and synergizing them with the existing, traditional power production technology. It is known that in coming times, wind energy will be the most cost-effective

renewable resource. Yet, it is doubtful if any individual technology would hold center-stage. Thus we selected kinetic motors means the “Energy in motion when it is suddenly applied with a sort of obstacle, then according to Newton’s law for every action there is an equal and opposite reaction. Utilization of this reaction is the basic reason behind the selection of this project work.”

2. Literature Review

There is an impending need to make much more forays to make Non-Conventional energy attain popular acclaim. This is also very essential to preserve the conventional sources of energy and explore viable alternatives like sustainable energy (the energy which we are already utilizing but for some safety of other uses we are suddenly wasting it, that can be reutilized), solar, wind and biomass that can enhance sustainable growth. What is more, such alternatives are environment friendly and easily replenish able. Therefore, they need to be thoroughly exploited with a functionally expedient, energy matrix mix. Growing economies, especially of Asia are gifted with sufficient resource base and non-conventional energy technologies are consistent both for grid linked energy generation and transmission in out of the way locales that are islanded from the grid. Adaptation of technology and employing them should be pursued right from this moment to have a head start, be informed of the barriers in technology applications of the renewable variety and synergizing them with the existing, traditional power production technology. It is known that in coming times, wind energy will be the most cost-effective renewable resource.

Yet, it is doubtful if any individual technology would hold center-stage. Thus we selected kinetic motors means the “Energy in motion when it is suddenly applied with a sort of obstacle, then according to Newton’s law for every action there is an equal and opposite reaction. Utilization of this reaction is the basic reason behind the selection of this project work. In order to perform this project literature review has been made for various sources like journal, books, articles and other. This chapter includes all important studies which have been done previously by other research work. It is important to do the literature review before doing the project because we can implement if there are information that related to this project. The most important thing before starting the project we must clearly understand about the topic that we want to do. So by doing the literature review we can gain knowledge to make sure we fully understand and can complete the project. A review of the article was performing to identify studies that relevant to the topic.

3. What Is Regenerative Suspension System

The method which converts linear motion into rotary motion. The rotational power is stored in flywheel & flywheel rotates dynamo, which generates electricity. When vehicles

move on speed breaker rack will be reciprocate. The rack is attached with pinion that rotates in one direction only. The rack & pinion arrangement convert linear motion in to rotary motion. This rotary motion is further magnified using chain drive. The output of free wheel is attached with flywheel which stores kinetic energy and transfer to dynamo which generate electricity.

The power generator electromagnetic suspension system is a system that converts vehicle bump generated linear motion & vibration, into electricity to be used in battery charging. General vehicle shock absorbers are used to simply absorb this energy without converting it to electricity. So here we put forth a way to use this free energy and store it for further needs such as vehicle lights, cooling, indicator lights etc. To achieve this we here use the principles of electromagnetism in order to generate electricity from this motion. Our shock absorber is made up of a metal shaft, spring, magnet, coils, base with screws and joints. It uses a coil wound around in particular turning arrangement over the inner beam of the part. We use cylindrical supports in order to minimize friction and ensure smooth generation. The head of the absorber consists of magnets attached to outer core which are aligned with inner core to ensure smooth motion while ensuring efficient generation. This arrangement is fitted with springs in a precise manner so as to achieve the desired motion and magnet coil overlapping which allows for generation of electricity through electromagnetism principle. Thus our system puts forward a smart power generation system using electromagnetic suspension system.

4. Scope of the project

In the past decade, regenerative braking systems have become increasingly popular, recovering energy that would otherwise be lost through braking. However, another energy recovery mechanism that is still in the research stages is regenerative suspension systems. This technology has the ability to continuously recover a vehicle's vibration less energy dissipation that occurs due to road irregularities, vehicle acceleration, and braking, and use the energy to reduce fuel consumption. Consumption; however, only 10%–16% fuel energy in the vehicles is utilized for driving to overcome resistance from road friction and air drag. In addition to thermal efficiency and braking energy, one important loss is kinetic energy dissipated by shock absorbers. The function of vehicle suspension system is to support the weight of vehicle body, to isolate the vehicle chassis from road disturbances, and to enable the wheels to hold the road surface. Two chief elements in suspension are spring and damper. Conventionally, damper is designed to dissipate vibration energy into heat to attenuate the vibration which is transmitted from road excitation. However, the dissipated heat is from fuel or electrical power. It is a pity that so much energy is wasted.

Energy absorbed by shock absorber is dissipated in terms of heat. Thus in this work attempts have been made to convert

dissipated energy in to electrical energy. In this project, design of regenerative suspension system is proposed, for improving the energy harvesting efficiency. Mechanical motion rectifier is used to convert oscillatory vibration into unidirectional rotation of generator. Modal and Vibration analysis is carried out of rack and pinion system to identify

displacement and stresses by using software, at various loads. Mode shapes are determined for each natural frequency. Mechanical rack and pinion system is used to generate power through regenerative shock absorber. This system can be used effectively in vehicles for power generation.

5. Methodology

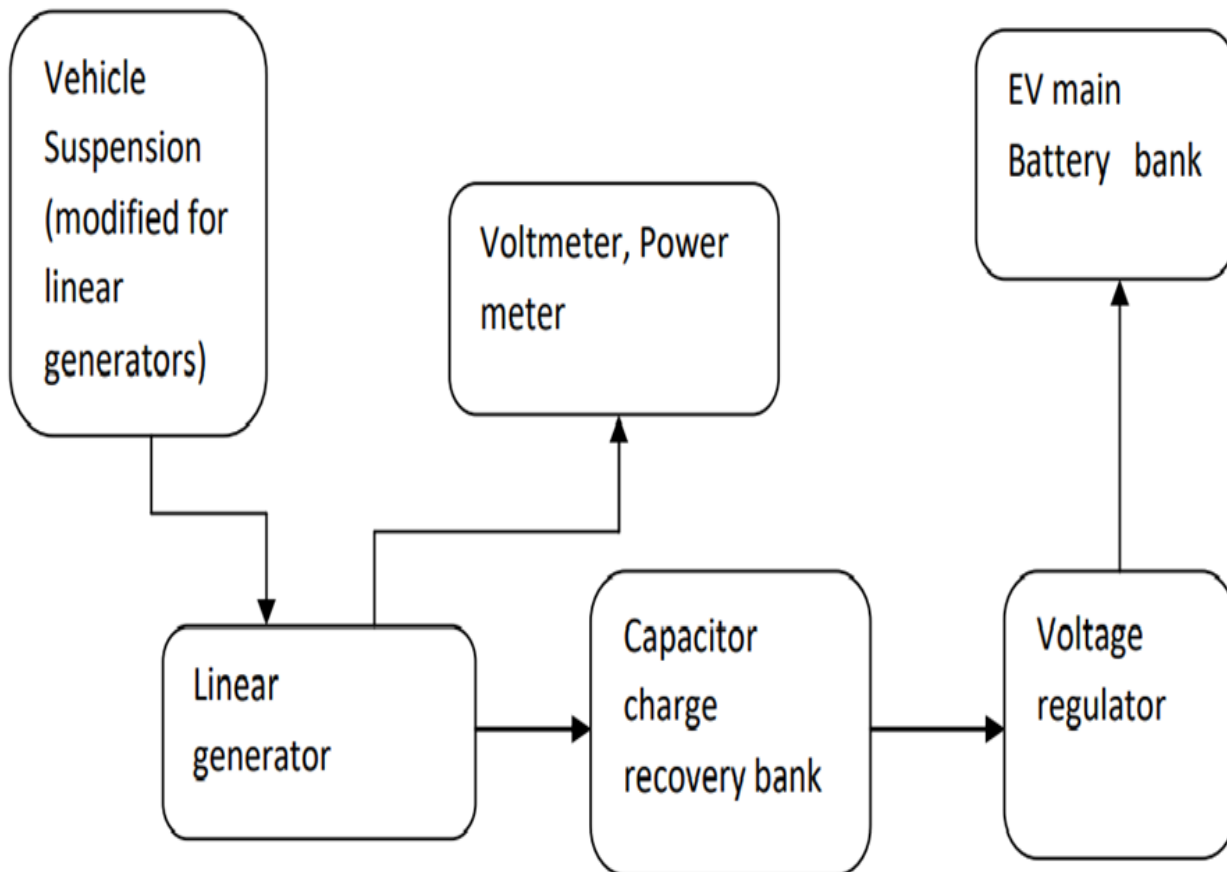

Fig -Block diagram

6. Working

In this project we have to develop a suspension energy generation unit by using rack and pinion method. It is less costly than the hydraulic unit.

- 1) Vertical movement of rack in actual operation is happened due to suspension movement, but for experimental purpose we give its movement by hand operation.
- 2) Hand lever is pushed by hand, this pushing of lever results in vertical movement of rack attached to the suspension frame.
- 3) This rack drives the pinion meshing with it.

- 4) On the pinion shaft 2nd gear is mounted which rotates with same RPM as of the pinion speed.
- 5) This 2nd gear drives the 3rd gear having bigger dia. Of 98 mm mounted on 2nd shaft.
- 6) On this 2nd shaft V-groove pulley is mounted.
- 7) Another pulley is mounted on alternator which is driven by belt drive.
- 8) As alternator shaft rotates it cuts the magnetic flux and EMF is generated at the output.
- 9) This EMF generated is used to glow the LED lamp, or we can measure the output voltage and current.

7. Advantages

- 1] Improved range of electric vehicles
- 2] Improved dynamic stability of the vehicles
- 3] Improved suspension ability of the vehicle
- 4] Improved energy efficiency
- 5] Reduced losses under any condition of the roads,
- 6] Can harvest power during breaking, acceleration,
- 7] Retardation, path holes, speed breakers.

8. Applications

- 1] All upcoming and all vehicles which are in use can be easily integrated with this kind of innovative technologies.
- 2] This system should be able to recover maximum amount of the energy from the suspension and storage system should be able to store it efficiently and use of this energy for the range extension of the vehicles

9. Conclusion

Suspension based power production will be extremely helpful for electric vehicles to extend the driving range without investing lot more on the batteries. Electric vehicle has limited battery life. This battery limitations make it unsuitable for use in long range drives thereby making them less suitable for most of the uses outside city driving. Our project will be solving this problem to a great extent using free source of power which is suspension based power generation system.

10. REFERENCES

- [1] Arekar, M.P. and Shahade, S. (2015).Power Generating Shock Absorber. International Journal of Innovative Research in Science, Engineering and Technology, Volume 4, Issue 3: 169-178
- [2] International Journal of Engineering Technology, Management and Applied Sciences www.ijetmas.com March 2015, Volume 3 Issue 3, ISSN 2349-4476
- [3] International Journal of Pure and Applied Research in Engineering and Technology, Research Article Impact Factor: 0.621 ISSN: 2319-507X Swapnil Kamthe, IJPRET, 2014; Volume 2 (9): 169-178 IJPRET
- [4] Proceedings of the World Congress on Engineering 2013 Vol III, WCE 2013, July 3 - 5, 2013, London, U.K.
- [5] International Journal of Engineering Science and Innovative Technology (IJESIT) Volume 3, Issue 4, July 2014

[6] Automobile Engineering Vol.1 by Dr. Kirpal Singh-(181-182

[6] Changhua Zhanga, Qi Huanga, Jiashen Tiana, Lei Chena, Yongxing Caob, Ran ZhangbSmart (2011), Grid Facing the New Challenge: the Management of Electric Vehicle Charging Loads, Energy Procedia 12, pp 98 – 103.

[7] Florida Public Service Commission Tallahassee, Florida, 2012

[8] Indian Passenger Vehicle Industry, An ICRA Perspective