

Switched Capacitor H-Bridge Multilevel Inverter Using Pulse Width Modulation for Grid

Miss. Rupali R. Moharkar¹, Prof. Umesh G. Bonde²

¹Department of Electrical Engineering, Shri Sai College of Engineering & Technology, Bhadrawati, Maharashtra, India

²Assistant Professor, Department of Electrical Engineering, Shri Sai College of Engineering & Technology, Bhadrawati, Maharashtra, India

Abstract - This paper present a single source cascaded H-bridge multilevel inverter using switched capacitor. The multilevel inverter consists of some of the series connected H-bridge cells. Where every cell needed a different dc source supply. Though in this system separate dc source is replaced by switched capacitor with single dc source supply. Along these lines by using this we can decrease the current spike which is harmful while charging the capacitor and it also give zero current changing condition to charging the switch. The software used for this test is Matlab/SIMULINK. This topology uses series and parallel combination of the basic unit to produce higher level output voltage. Multilevel inverters have their many applications in renewable energy systems. This new multilevel inverter using switched capacitor units can also be used for renewable energy applications.

Key Words: Multilevel Inverter, CMI, Switched Capacitor.

1. INTRODUCTION

The Switched Capacitor Multilevel Inverter can deliver the ideal sinusoidal voltage waveform and lift the input voltage with no massive transformer. In view of the inherent voltage unbalancing of capacitors in the switched capacitor multilevel inverters, utilizing convoluted capacitor voltage adjusting is essential. Capacitor voltage adjusting procedures will be more complex when higher number of voltage levels is delivered at the output. To relieve this issue, the hybrid-source switched capacitor topologies can be utilized. By utilizing this sort of inverter with less switching devices and less complex control strategies, it is possible to accomplish a greater number of voltage levels at the output. The hybrid source switched capacitor topologies can be utilized in electric vehicle application. The hybrid multilevel inverter utilizing exchanged capacitor units comprise of a blend of the customary arrangement and equal switched capacitor units. The hybrid multilevel inverter topology utilizing switched capacitor units lessens number of switches and separated DC voltage sources, the assortment of the DC voltage source values, and the size and cost of the framework in examination with the ordinary topologies. Likewise, this topology can support the information voltage without a transformer.

In this cascaded H-bridge multilevel comprise of some the power semiconductor devices and disconnected dc supply. The H- bridge cells are associated in arrangement with one another with discrete dc source supply. The combination of capacitor and switches is called as H- bridge with discrete input dc source for every cell. Thusly cascaded H bridge multilevel inverter require less number of segments and furthermore he control framework is basic contrasted with neutral clamped and flying capacitor multilevel inverter. The primary burden of this multilevel inverter is that it requires a few isolated dc source. By considering the above issue some of researchers attempt to decrease the quantity of dc source in cascaded multilevel inverter. One of the arrangements is utilizing phase low frequency transformer rather than a few dc source to give an enormous number of output voltage level however the output voltage is dictated by input dc voltage and transformer turns proportion in this manner legitimate transformer proportion should be picked, they give a galvanic isolation. The disadvantage of this technique is that the framework is bulky and costly. The other arrangement is utilizing a high frequency connection and transformer to give a supply to a few dc sources. Despite the fact that by utilizing this strategy it decreases the complete size, it requires additional number of segment to build up the high frequency link and a few isolated dc source.

The present paper proposed a single source cascaded H-bridge multilevel inverter using switched capacitor. In this proposed paper replacing the several isolated dc sources by switched capacitor with single dc source. This proposed paper presents some of the feature: 1.It use single dc source and the rest of the dc source are replaced by some of the capacitor. 2. It as self-balancing capability. 3. It reduces the leakage current 4. It produces low harmonic distortion.5. It has ability to boost the staircase ac voltage.

2. Literature Survey

- 1) "Comparison of Cascaded H-bridge Multilevel Inverter Topologies with THD Analysis" by Jyoti M. Kharade, Vidya M. Patil, Onkar A. Bhadule,

Shubhangi S. Patil, Sujit S. Jadhav in IJIRSET Vol. 6, Issue 3, March 2017. In this paper the said that, The project mainly focuses on the comparison of cascade H-bridge multilevel inverter with THD analysis. The main objective of our project is to increase number of levels with a low THD and sources at the output without adding any complexity to the power circuit. The main advantage of this topology is to reduce the Total Harmonic Distortion (THD), lower electromagnetic interference generation and achieve high output voltage. The Pulse Width Modulation technique has proposed which can minimize the total harmonic distortion and enhances the output voltages from proposed work of seven level inverter. The operation of single-phase three level & seven level cascaded H-bridge multilevel inverters are being analysed in this project. The comparison of performances of these two topologies will be discussed on the basis of various parameters such as voltage levels, number of switches, THD level and output. In this project work hardware model of Seven-level single phase cascade H-Bridge inverter has been developed using MOSFET. Gating signals for these MOSFET have been generated by comparators. In order to maintain the different voltage levels at appropriate interval, the conduction time intervals of MOSFETS have been maintained by controlling the pulse width of gating pulses (by varying the reference signal magnitude by the comparator). The results of hardware are compared with simulation result. Simulation model (designed in SIULINK) have developed up to seven level and THD in all the cases have identified.

- 2) "Switched-Capacitor Based Single Source Cascaded H-bridge Multilevel Inverter Featuring Boosting Ability" by Hossein Khoun Jahan, Mehdi Abapour, Kazem Zare in IEEE 10.1109/TPEL.2018.2830401. in this paper they discussed that, cascaded multilevel inverter (CMI) is one of the most popular multilevel inverter topologies. This topology is synthe-sized with some series connected identical H-bridge cells. CMI requires several isolated dc sources which brings about some difficulties when dealing with this type of inverter. This paper addresses the problem by proposing a switched capacitor (SC) based CMI. The proposed topology, which is referred to as switched capacitor single source CMI (SCSS-CMI), makes use of some capacitors instead of the dc sources. Hence it requires only one dc source to charge the employed capacitors. Usually, the capacitor charging process in a SC cell is accompanied by some current spikes which extremely harm the charging switch and the capacitor. The capacitors in SCSS-CMI are charged through a simple auxiliary circuit which eradicates

the mentioned current spikes and provides zero current switching condition for the charging switch. A computer-aid simulated model along with a laboratory-built prototype are adopted to assess the performances of SCSS-CMI, under different conditions.

- 3) "Multilevel inverter topology using single source and double source module with reduced power electronic components" by Nagaraj Vinoth Kumar, Venkatachalam Kumar Chinnaiyan, Pradish Murukesapillay, Shanmugam Prabhakar Karthikeyan in The Journal of Engineering 10.1049/joe.2017.0068. in this paper they said that, Two-level inverters are the most basic subset of multi-level inverters (MLIs). As the number of output levels increase, totalharmonic distortion reduces and the performance level increases. In traditional MLI topologies, more number of power devices are involved to obtain higher order inverters which increases cost, complexity and volume. By minimising the use of power component, overall cost can be reduced. In this study, a MLI structure is proposed with minimised power components. The reduction of components are achieved through single and double source modules such as single source and single switch, single source and switch with parallel diode and double source and single switch with parallel diode. In the proposed MLI structure, the switches are reduced by half in comparison with cascaded MLI and hence the percentage in reduction of switches increase as the levels increase. For better appreciation, the proposed topology is compared with the current state of the art in MLI. This topology is modelled and simulated using LTspice and MATLAB/SIMULINK R2014 a. The prototype is designed and validated for seven and nine levels experimentally.
- 4) "Hybrid Five-Level Inverter using Switched Capacitor Unit" by Minu M Sageer in IJIRST Volume 3 - Issue 04 - September 2016. In this paper they discussed about, A multilevel inverter is a power conversion device that produces an output voltage in the desired levels by using DC voltage sources at the input. The number of DC voltages and switches increases with number of output voltage levels for the conventional topologies. This is the main drawback of the conventional topologies. Here a new multilevel inverter is presented, which uses switched capacitor units. The switched capacitor multi-level inverter can produce the desired output voltage and also can boost the input voltage without any bulky transformer. Also, the number of switches and DC voltage sources are reduced in this topology. This reduces the size and cost of the inverter. This

topology uses series and parallel combination of the basic unit to produce higher level output voltage. In this paper the operation and simulation results of a hybrid five-level inverter is presented using MATLAB/Simulink software. Multilevel inverters have their many applications in renewable energy systems. This new multilevel inverter using switched capacitor units can also be used for renewable energy applications.

- 5) "Switched Capacitor Based Multilevel Inverter Topology Compatible with Multiple Inputs" by Sajina S1, Frieda Mohan2 in IJIREEICE Vol. 7, Issue 2, February 2019. In this paper they said that, A switched capacitor based multilevel inverter employing asymmetric source configuration is proposed. Multilevel inverters are mainly used to improve the harmonic profile of the output by increasing the number of levels. Due to the advancement in renewable energy, asymmetrical DC voltage sources are more common. The significant reduction in switch count of multilevel inverters has served as the greatest advantage over years. Various modulation schemes have been proposed in the literature to enhance the performance of multilevel inverters. This include Sinusoidal PWM (SPWM), Space Vector Modulation (SVM), Selective Harmonic Elimination (SHE) etc. The switching strategies used for the control of switches influence the harmonic content of output voltage. Most of the modulation techniques, however contributed less in reducing the distortion at the output. In order to control the noise signals, lower order harmonics should be controlled. A modified Reduced carrier PWM scheme is proposed to control the harmonic content of the output voltage and thereby reduce the Total Harmonic Distortion. The simulation of the proposed system is modelled and evaluated with desirable results in MATLAB/Simulink.

3. SYSTEM CONFIGURATION

A] Hybrid Multilevel Inverter Using Switched Capacitor Units

The term "hybrid" means 'a thing made by combining two different elements, of mixed characteristics, composed of different elements'. Thus the hybrid multilevel inverter is a combination of a switched capacitor topology and an H-Bridge.

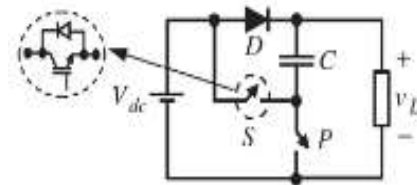

Fig - 1: Basic Switched Capacitor Unit

Figure 1 shows the fundamental unit of an switched capacitor topology. The basic circuit contains one DC power supply, one capacitor, one power diode and two series/parallel unidirectional power switches. The switches P and S connect the capacitor in parallel and series with the DC voltage source, separately. At the point when the switch P is turned ON, the capacitor is charged to the voltage V_{dc} , and when the switch S is turned ON, the capacitor begins to release. The switches P and S have complementary activity with one another, which implies that, when the switch P is ON, the switch S should be OFF and the vice versa. Otherwise, a short circuit occurs across the DC voltage source. At the point when the switch S conducts, the diode D becomes reverse biased and prevents capacitor discharging to the DC voltage source. Along these lines, in the case of series connection of the capacitor and DC voltage source (S is ON), the capacitor current only flows to the load.

B] H-Bridge Unit

An H-Bridge Unit produce positive, negative and zero voltages at the output. Figure 2 shows an H-Bridge unit.

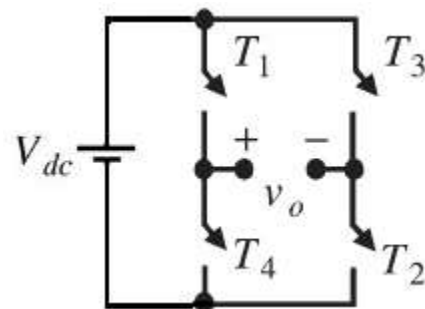

Fig - 2: H-Bridge Unit

An H-Bridge unit consists of a DC power supply and four switches T_1 , T_2 , T_3 and T_4 . When T_1 and T_2 conducts a positive output voltage is produced. And when T_3 and T_4 conducts a negative voltage is produced. If two switches of the same leg (i.e. if T_1 and T_4 or if T_2 and T_3) are ON or if no switches are turned ON, then the output voltage will be zero.

C] General Topology of a Hybrid Multilevel Inverter using Switched Capacitor Units

Figure 3 shows the generalized topology of a Hybrid Multilevel Inverter using Switched Capacitor Units.

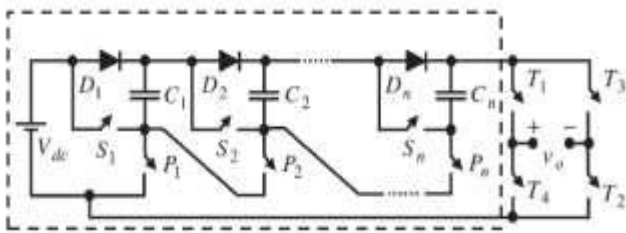

Fig - 3: Generalized Topology of a Hybrid Multilevel Inverter using Switched Capacitor Units

The generalized topology is derived from the series combination of several basic units. The switches S_i ($i = 1, 2, \dots, n$) connect the capacitors in series, and the switches P_i connect the capacitors in parallel with the DC voltage sources. To produce zero and negative voltage levels, an H-bridge has been used at the output. When T_1 and T_2 conducts a positive output voltage is produced and when T_3 and T_4 conducts a negative voltage is produced. If two switches of the same leg of the H-bridge conduct or if all the switches of the H-bridge are open, then the output voltage will be zero. The blocked voltage by each switch in Figure 3 is V_{dc} .

4. CONCLUSION

A new switched capacitor based nine level inverter employing reduced carrier PWM scheme is proposed here. The inverter is capable of operating with multiple sources. Such situations arise when large firms use different renewable sources for the electric power generation. As series connection of multiple sources is not used, the issue of voltage balancing can be eliminated. The high frequency of the output makes it possible to be employed with special applications such as aerospace. The reduced carrier PWM method with unified logical expressions helped in the proper switching of the components and made it possible to reduce the THD. The even order harmonics were completely eliminated and the lower order odd harmonics were minimized. If multiple sources are available, the system can be extended to obtain more levels and hence a more efficient output can be obtained.

REFERENCES

- [1] Ebrahim Babaei and Saeer Sheer Mohammad Zadeh Gowgani, "Hybrid multilevel inverter using switched capacitor units" IEEE Trans. Ind. Electron., vol. 61, no. 9, pp. 4614–4621, Sept. 2014.
- [2] J. Rodríguez, J. S. Lai, and F. Z. Peng, "Multilevel inverters: A survey of topologies, controls and applications," IEEE Trans. Ind. Electron., vol. 49, no. 4, pp. 724–738, Aug. 2002.

- [3] A. Nabae, I. Takahashi, and H. Akagi, "A new neutral point clamped PWM inverter," IEEE Trans. Ind. Appl., vol. IA-17, no. 5, pp. 518–523, Sep. 1981.
- [4] Y. Ounejjar, K. A. Haddad, and L. A. Gregoire, "Packed U-cells multilevel converter topology: Theoretical study and experimental validation," IEEE Trans. Ind. Electron., vol. 58, no. 4, pp. 1294–1306, Apr. 2011.
- [5] A. K. Sadigh, S. H. Hosseini, M. Sabahi, and G. B. Gharehpetian, "Double flying capacitor multicell converter based on modified phase-shifted pulsewidth modulation," IEEE Trans. Power Electron., vol. 25, no. 6, pp. 1517–1526, Jun. 2010.
- [6] J. Chavarria, D. Biel, F. Guinjoan, C. Meza, and J. J. Negroni, "Energy balance control of PV cascaded multilevel grid-connected inverters under levelshifted and phase-shifted PWMs," IEEE Trans. Ind. Electron., vol. 60, no. 1, pp. 98–111, Jan. 2013.
- [7] M. Malinowski, K. Gopakumar, J. Rodriguez, and M. A. Perez, "A survey on cascaded multilevel inverters," IEEE Trans. Ind. Electron., vol. 57, no. 7, pp. 2197–2206, Jul. 2010.
- [8] M. F. Kangarlu and E. Babaei, "A generalized cascaded multilevel inverter using series connection of submultilevel inverters," IEEE Trans. Power Electron., vol. 28, no. 2, pp. 625–636, Feb. 2013.
- [9] C. M. Young, N. Y. Chu, Y. C. Hsiao, and C. Z. Li, "A single-phase multilevel inverter with battery balancing," IEEE Trans. Ind. Electron., vol. 60, no. 5, pp. 1972–1978, May 2013.
- [10] E. Babaei, "A cascade multilevel converter topology with reduced number of switches," IEEE Trans. Power Electron., vol. 23, no. 6, pp. 2657–2664, Nov. 2008.