

SPEED CONTROL OF BLDC MOTOR USING ARDUINO & PWM TECHNIQUE

JANHAVI REWATKAR¹, ASHWINI IRPATE², RUNALI NAVGHADE³, PANKAJ KUBDE⁴, Dr. RAHUL BURANGE⁵

^{1,2,3,4}Student, Department of Electronics Engineering, K.D.K.C.E, Nagpur, India

⁵Professor & HOD, Department of Electronics Engineering, K.D.K.C.E, Nagpur, India

Abstract -This paper describes overview of various researches on Speed Control of BLDC Motor using Arduino and PWM Technique. Brushless DC (BLDC) motors are becoming more common in a variety of motor applications such as fans, pumps, automotive drives & robotic automations. We have a lot of technologies that can be used to control the speed of BLDC motor. Those systems and techniques we are discussing in this paper. We have seen various techniques to control Brushless Direct Current (BLDC) motor like techniques using mobile application, Bluetooth module, by sending SMS from mobile phone, etc. But for those technologies there are different mythology and platforms. And these types of systems are very much expensive. Because of this these expensive systems are not affordable by everyone. Our main aim to design a system which is advanced, useful, easy to handle and cheapest. That's why we are control the speed of BLDC motor using Arduino & PWM technique.

Keywords: Arduino, PWM, Bluetooth, BLDC Motor, Robotic Automation.

1. INTRODUCTION

A Brushless Direct Current (BLDC) electric motor is also known as an Electronically Commutated Motor (ECM or EC Motor) or synchronous motor because it uses direct current (DC) electric power supply. BLDC motor uses an electronic closed loop controller to switch DC currents to the motor windings producing magnetic fields. Permanent magnet excited BLDC motors are becoming increasingly attractive in a large number of applications. The reason for their increased popularity is better speed versus torque characteristics, long operating life. The BLDC motors are useful in applications where space and weight are critical factors. Unlike a brushed DC motors, the commutation of a BLDC motors is controlled electronically.

Brushless DC motors has various applications used in industries like in drilling, lathes, spinning, electric bikes, etc. because of its performance advantages such as

reduced size, low cost, reduced torque ripples, high efficiency, increased torque-current ratio, low maintenance, low noises & good control characteristics over a wide range in torque-speed plan. BLDC Motors is widely used in small and medium size electric vehicles. The speed control of brushless DC motors is archived by varying the duty cycles of PWM pulses and delivered the desired output to the BLDC motor to control the speed.

2. LITERATURE SURVEY

1. Speed & Direction Control of DC Motor using Android Mobile Application [1]

The implementation of microcontroller, to control the speed and direction of a dc motor in either direction i.e. clockwise or/and anticlockwise, using android mobile application. A high frequency PWM signal is fed to dc chopper that is used to drive the dc motor. By controlling the duty cycle of this PWM signal, the terminal voltage of dc motor is controlled, which in turn directly controls the speed of dc motor. In this system, a dc motor is interfaced with the microcontroller. The major elements used in this system are Arduino UNO, Bluetooth module and DC motor. A 12v transformer powers the entire system. When an android device sends command, it is received by the Bluetooth module, which then sends the commands to microcontroller. Whenever the motor is turned on, it can run in both directions. A LCD is used to display the status and speed of dc motor. To control the signal speed and direction of dc motor, a signal from android device will be sent to microcontroller through Bluetooth module. This signal will be represented by a single direction that denotes the speed and direction of the motor. Different letters will represent the three directions of rotation i.e. clockwise, anticlockwise and stopping of the motor. This letter will vary the speed of motor with reference to Arduino code. The duty cycle of PWM signal is varied in between 0-255 to change the speed of dc motor. Direction of DC motor is controlled by using H-bridge concept. [1]

2. DC Motor Speed Control using SMS Application, Journal of Intelligent Control and Automation 5.[2]

Simple technique is used to control the speed of DC motor by sending SMS from mobile phone. The GSM module will receive SMS of desired motor speed in RPM send by the user. SMS received on the GSM module will be proceed by MCU and MCU will convert the SMS into suitable duty cycle for PWM pulse to control the speed of the DC motor. MCU is programmed to continuously send an AT command to the GSM module to check for message in the SIM every 5 second at location 1. Program will go to next step after receiving the message after that, MCU will receive the SMS, extract the speed & change it to a suitable duty cycle for the PWM. Suitable voltage is produced by controlling the motor drive L2931 using PWM pulse. This suitable voltage is supplied to the motor so that desired speed can be achieved. After completing this process, message was deleted at location 1 of GSM module by using AT command & loop back to the first step & again read the SMS in SIM. This process will repeat continuously. There are many advantages of controlling a motor using SMS i.e. Manual work will be reduced as the speed of motor is controlled by giving instruction to the MCU, cost of wiring will also get reduced by using wireless technology, using this method speed of DC motor is controlled wirelessly from far distance.[2]

3. Speed Control of DC Motor via Internet for Traction Applications.[3]

This system consists of a rectifier, filter capacitor, DC/DC converter. The main component of DC/DC converter is IGBT, which is driven by PWM pulses fed from the microcontroller. An Arduino Ethernet shield is used to connect the Arduino on board microcontroller to the internet by plugging the Ethernet module to RJ45 cable. By scrolling the slider in android app, the data is sent to the microcontroller through internet. The slider is configured with 0-255 digital values. According to the value that is fixed by the user, the data is sent to Ethernet shield and the corresponding pulse with duty ratio is achieved. The speed of the motor is controlled by driving the IGBT through the microcontroller signal.[3]

4. Speed Control of BLDC Motor through Mobile Application via Secured Bluetooth.[4]

The speed control of BLDC motor through mobile application via secured Bluetooth. For controlling the

speed and direction of a BLDC motor signal is sent by the android application and further transmitted to the Bluetooth module & received by Arduino Uno. With the help of this scheme, we can drive the motor in clockwise or anticlockwise direction. Direction of motor is controlled by reversing the direction of current flow either in armature or in field winding of the BLDC. This technique uses four main hardware's Arduino Uno ATmega328 microcontroller, Android mobile, BLDC motor & Bluetooth module. In this technique, user send the instruction to the Arduino Uno ATmega328 microcontroller via android mobile, which is wirelessly connected with the Bluetooth module. The Bluetooth module reads the information sent by the user & further sends to the Arduino Uno microcontroller, which drives the BLDC motor. PWM technique is used to control the speed & direction of BLDC motor. PWM technique is most widely used for speed control application. Speed of DC motor is controlled by varying the duty cycle of PWM pulse. Speed of motor increases when duty cycle is increased & motor speed decreases as duty cycle is decreased. In this paper, researchers conclude that Arduino Uno is used for controlling the speed & direction of BLDC motor via Bluetooth. Terminal voltage has been changed with change in duty cycle. PWM control vary the duty cycle. [4]

3. PROPOSED WORK

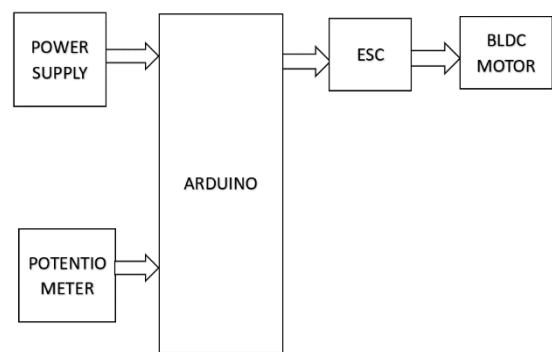

Fig 3.1: Block diagram of purpose system.

We are designing Speed control of Brushless Direct Current (BLDC) motor using Arduino & PWM technique. There are different techniques to control the speed of BLDC motor but they are quite expensive and have some limitations to operate. That's why we are using Arduino uno board and PWM technique which is advanced, cheaper in price to used in many appliances, robotics automation, many small-scale industries, etc.

This system consists of Arduino Uno Board, BLDC Motor, ESC (Electronic Speed Controller), Potentiometer, 12V DC Battery. ESC is connected

between BLDC motor and Arduino. It is a motor driver circuit which is used to change the speed of an electric motor. This ESC provides regulated 5V to power the Arduino. BLDC motor consist of two parts i.e. stator and rotor. To rotate the BLDC motor, the stator winding should be energized in a sequence. To control or change the speed of motor we used potentiometer. The potentiometer connected to Arduino for controlling the motor speed. With the help of potentiometer, we can control the current which is transfer to drive BLDC motor in the form of PWM waves.

4. HARDWARE REQUIREMENT

- Arduino Uno Board
- BLDC Motor
- ESC
- Potentiometer
- Connecting wires
- Power Supply
- 12volt dc battery

5. CONCLUSIONS

From this literature survey we have seen lots of technology that controls the speed of Brushless Direct Current (BLDC) Motor. Those various technologies uses Bluetooth Modules, SMS application, through Mobile applications, GSM Modems, etc. These systems are expensive, quite difficult to handle and have some limitations to use. Hence, we want to implement a system which is advanced, easy to handle and cheapest in price. That's why we are designing "Speed Control Of BLDC Motor using Arduino & PWM Technique".

6. REFERENCES

- [1] Ritesh Chaubey, Deepak Kumar, Saketh, Dr. Sudeshna, "Speed & Direction Control of DC Motor using Android Mobile Application", International Journal of Electrical Electronics & Computer Science Engineering.
- [2] N.Barsoum, "DC motor speed control using SMS application, Journal of Intelligent Control and Automation 5", 2012.
- [3] V.J. Sivanagappa, K. Haribalan "Speed control of DC motor via Internet for Traction Applications" IEEE, 2016.
- [4] Arindam Bhattacharjee, Gaurav Ghosh, Vijay Kumar Tayal, Pallavi Choudekar, "Speed Control of BLDC Motor through Mobile Application via Secured Bluetooth", Recent Development Control & Power Engineering (RDCAPE), 2017.
- [5] A. Khanna and P. Ranjan, "Solar Powered Android Based Speed Control of DC Motor via Secure Bluetooth", IEEE, 2015.
- [6] Ankesh N.Nichat, Sheikh Kadir Ali, Yogesh D. Solanke, Amit M.Dodke, "Wireless Speed and Direction Control of DC Motor by Using Radio Frequency Technology.
- [7] Hemalatha, M. C., Nagarajan, M. R., Suresh, P., Shankar, G. G., & Vijay, A. (2017). Brushless DC Motor Controlled by using Internet of Things. IJSTE-International Journal of Science Technology & Engineering, 3(09), 373-377.
- [8] Lefley, P., L. Petkovska, and G. Cvetkovski. Optimization of the design parameters of an asymmetric brushless DC motor for cogging torque minimization in Power Electronics and Applications (EPE 2011), Proceeding of the 2011-14th European Conference on 2011.
- [9] G.H. Jang and M.G. Kim, "A Bipolar-Starting and Unipolar-Running Method to Drive an HDD Spindle Motor at High Speed with Large Starting Torque," IEEE Transactions on Magnetics, Vol. 41, no.2, pp. 750- 755, Feb. 2005.
- [10] S.Baldursson, "BLDC Motor Modelling and Control- A MATLAB/Simulink Implementation", Master Thesis, May 2005.
- [11] Tashakori, A., Ektesabi, M., & Hosseinzadeh, N. (2011, July). Modeling of bldc motor with ideal back emf for automotive applications. In Proceedings of the World Congress on Engineering (Vol. 2, pp. 6-8).
- [12] An Introduction to Sensorless Brushless DC Motor Drive Applications with the ST72141 Application Note. AN1130, STMicroelectronics; Geneva, Switzerland: 2000.
- [13] Duane H. (2002) Brushless Permanent Magnet Motor Design. University of Maine, Orno, USA 2nd ed.
- [14] Khader S. H. (2001) Implementation of an accurate mathematical method for modelling electromagnetic processes of brushless DC motor. MESM, Amman, Jordan, 31-38.
- [15] R.Krishnan, "Electric Motor Drives Modeling, Analysis, and Control, Prentice Hall International Inc., New Jersey, 2001.