

Automation in Street lights Control

Mr. Nikhil Vishwas Ghag¹, Miss. Anjana Nabaghan Nayak², Miss. Namrata Narayan Kule³

¹⁻³Student P.G. (M.Sc. I.T.), D.B.J. College, Chiplun, Ratnagiri, Maharashtra, India 415605.

Abstract: Street lights area unit controlled manually in past days. Currently automation of street lights has emerged. However one will observe that there's no would like of high intensity in peak hours i.e. once there's no traffic and even in early mornings. By reducing the intensity in these times, energy may be saved to some extent. There area unit several ways to save lots of the ability like shift the road light-weight on police investigation vehicle etc. Auto Intensity Control of Street Lights may be a straightforward project wherever the intensity of the road lights is mechanically controlled supported the daylight conditions. Generally, street lights area unit turned on throughout night time and can still glow until morning. This project helps to save lots of energy. So as to save lots of energy, the circuit's area unit designed with high intensity LEDs

Key Words: -Street Lights, Street light based on sunlight Condition, reducing intensity of light.

1] INTRODUCTION

Due to the innovation of Embedded System our daily work becomes easier and also fully automatic. An embedded system is an electronic/electro-mechanical system designed to perform a specific function and is a combination of both hardware and software. [1]

The main principle of this project is to regulate the intensity of street lights using Arduino. Peak hours of a specific space are calculated and consequently daylight is adjusted by RTC Module (DS3231) and LDR to extend or decrease the intensity of street lights.

These peak hours is calculated by considering parameters like time, and light-weight intensity of the surroundings.

2] OBJECTIVE OF SYSTEM

- The aimed of this System is detecting Sunlight and then as per sunlight Manage Street Light.
- Save Lot of energy.
- Make the street light control System Automatic.
- Since automatic street light-weight systems feature no moving components, they need less maintenance than typical street light

3] COMPOENTS USED IN PROPOSED SYSTEM

3.1] Hardware Used:-

- Arduino UNO
- DS3231 RTC Module
- LDR
- 16×2 LCD Display
- LED
- 10KΩ Potentiometer
- 10KΩ Resistor
- Push Button
- Connecting Wires
- Breadboard

3.2] Software Used:-

Arduino IDE: The Arduino Integrated Development Environment (IDE) is a cross-platform application (for Windows, mac OS, Linux) that is written in the programming language Java.[2] The Arduino IDE supports the languages C and C++ using special rules of code structuring.[2]

We have used a code in C++ according to working requirements of the project.

4] COMPOENTS

4.1] Arduino UNO Microcontroller:-

The Arduino UNO is an Open-source microcontroller board based on the microchip ATmega328P microcontroller and developed by Arduino.cc. The Board is Equipped with sets of digital and analog input/output pins that may be interfaced to expansion Board and Other Circuits [3].

4.2] DS3231 RTC Module:-

The DS3231 is an RTC IC developed by Maxim Integrated. It's a lower in cost. It is more accurate RTC IC with communication over I2C Interface.

4.3] LDR Sensor:-

LDR Sensor is use to sense presence and absence of light.

4.4] 10KΩ Potentiometer:-

It is used for calibration of resistance value.

5] WORKING PRINCIPLE

- The main goal of this system is to detect sunlight and as per sunlight this system adjust street light. This embedded system is designed with sensors, actuators and a microcontroller.
- This System is mainly use in evening and night time. This system manages street light according to sunlight.
- The main advantage of street lights is that they increase safety and prevents accidents and collisions.

6] THE BLOCK DIAGRAM OF PROPOSED SYSTEM

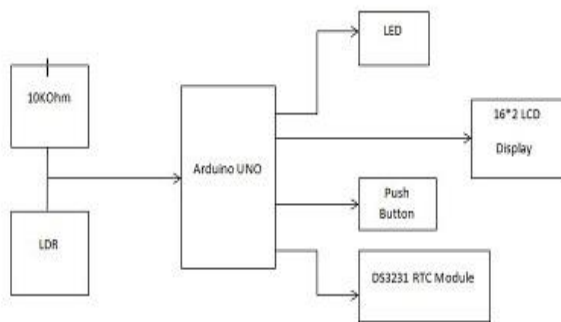

Fig. Block diagram of whole model

5.1] Working of Temperature and Humidity Sensor and GSM Module

This project mechanically activates the street lamp at evening and turns off within the morning. It also controls the intensity of street light as per sunlight. Light intensity is automatically adjusted according to the sunlight and time.

The intensity of street light is low in the evening and it starts increasing evening after evening the LED glows at full intensity and this intensity will not change. It glows on full intensity until midnight and intensity of LED Light starts decreasing after Midnight, and the lights are fully turned off after 6AM. This approach saves about much more energy.

The Automation in street light control works in two stages. The primary stage consists of reading some external environmental parameters

Like sunlight, time. The first stage is done with the help of LDR sensor which is used to measure the sun light and convert analog data to digital data.

The sensor read parameters like sunlight and then sends this information to the Arduino.

The sensor sends their measurements to Arduino and store the information for the next process. There is a predefined threshold value to these parameters. The microprocessor compares the sensor measure value at regular intervals of times with the predefined values. Based on the comparison if the input values of sensors exceed the threshold and as per sunlight and time LED started Blinking.

6] CONCLUSIONS

This project is for saving power and implemented using automation in Street light control and also this system can be applicable for real time use.

The work is to design the model to predict and monitoring the sunlight. This system model gets the data and controlled using the Arduino. System Monitor Environment and As per

Environment LED Started Blinking.

The solution to energy conservation is to eliminate slot and introduce a system that would sense brightness surroundings and act consequently so seasonal changes wouldn't have an effect on the intensity of street lights.

7] REFERENCES

7.1] Book References

- [1] Shibu K. V. - Introduction to embedded systems
- [2] Pajankar Ashwin "Arduino Made Simple"

7.2] Web References

- [3] https://en.m.wikipedia.org/wiki/Arduino_Uno

8] BIOGRAPHY:



Mr. Nikhil Vishwas Ghag
Student P.G. [M.Sc. I.T.),
D.B.J. College, Chiplun,
Ratnagiri, Maharashtra,
India 415605



Miss .Anjana Nabaghan
Nayak Student P.G. (M.Sc.
I.T.), D.B.J. College,
Chiplun, Ratnagiri,
Maharashtra, India
415605



Miss. Namrata Narayan
Kule Student P.G. (M.Sc.
I.T.), D.B.J. College,
Chiplun, Ratnagiri,
Maharashtra, India
415605