

ALUMNI TRACKING SYSTEM

Shashank Jaiswal¹, Sandhya Gaud², Shaifali Ansari³, Rajesh Gaikwad⁴

^{1,2,3}UG Student, Shree LR Tiwari College of Engineering, Thane, Maharashtra, India

⁴Assistant Professor, Shree LR Tiwari College of Engineering, Thane, Maharashtra, India

Abstract: Alumni Tracking System is an online-based application that helps to tracking of college graduates. The project aims to improve current tracking procedure of college graduate and providing alumni data to college faculties. It aims to developing a web portal which will be useful for the college to monitor the alumni and for the alumni to update their current status about the college activities. The proposed of this system is to provide an optimized solution for collecting and managing the alumni data. The system will be an all-in-one place to handle alumni data, to enable communication between alumni and the institution and provides great flexible features to keep track of the data. The user can update their information by simply filling the forms and uploading their file. One more advantage of the proposed system is that, generally alumni forum will be managed by group of alumni which would be an overhead to them, this system is automated hence does not require maintenance effort from the alumni side.

Key Word: Alumni-tracking, Web-portal, chirp (similar to twitter), event-section, news-section, career-section, admin, super-admin.

1. INTRODUCTION

The Communication between graduates and the institution can be very beneficial in many situations. For instance, the institution may be interested in extending an invitation for a guest lecture to one of its alumni who is a very successful entrepreneur now. But without having proper contact, the institution will have to spend time tracing the contact. Thus, maintaining consistent data goes hand-in-hand with establishing proper communication.

The proposed of this system is to help in accomplishing this, where alumni can communicate among themselves, with their juniors and with the organization. This way they can build a strong network of professionals. This system proves to be beneficial to the current students of the institution since they get the contacts of their seniors from whom they can seek for opportunities and guidance.

The admin can communicate with the alumni as well and be notified of any update made by the users to their profile through weekly reports. Apart from communication and admin report, the system also allows users to create events. The upcoming events would be displayed in the home page; thus, the user would be reminded of the events to be happening so that they would not miss out any important event.

1.1 Background and Motivation

Each year many students graduated from their respective universities or colleges. It's is very hard for the colleges and universities to maintain their comprehensive data and result in lack of communication between alumni and their alma mater. Even if we have to invite any alumni for meeting or events it will be very difficult for colleges or universities to contact them. Many of alumni will start their venture after graduation, for colleges to make sure that this alumnus takes best of mind from their college it is necessary to have a relationship with those alumni.

1.2 Project Scope

This project can be implemented in every domain of sphere be it social, commercial or industrial with certain modifications and each of it with different usage and have their own certain requirements. Social usage of this project would be maintaining the donor status so any NGO can used it for this usage with certain modifications.

Industrial and Commercial usage of this application would be maintaining employee or retired employee's data with certain requirements modification.

2. Proposed System

The proposed system will be web-based applications so it can be accessed by alumni and students with the help of Internet. It enables quick and easy communications. Each user will be responsible for updating their own information's. Admin and Super-admin will be able to organize meetings and find out about job opportunities using this system.

This concept is implemented as a web application so that it targets a wide range of users where the user can access the system from anywhere and at any time through internet. The implementation is done in such a way that it reduces load on the administrator's side in maintaining the updates made by the users. It had many features which includes data analytics, networking, database management and manipulation.

Table 1: Traditional vs Proposed System.

TRADITIONAL	PROPOSED
1.Data is inaccessible from anywhere because it is not stored in server.	1. Since all data are stored on server it can be accessed anywhere at any time.
2.System does not include networking in any manner.	2. Networking of alumni is one key features of system.
3.Data is not segregated in broader context.	3. In system segregation of data elementary of key concept.

3. Architecture

We will start with making a registration user system for which we have developed a new architecture which we like to call it a 3-tier user architecture.

Figure 3.1: 3-Tier Architecture Diagram

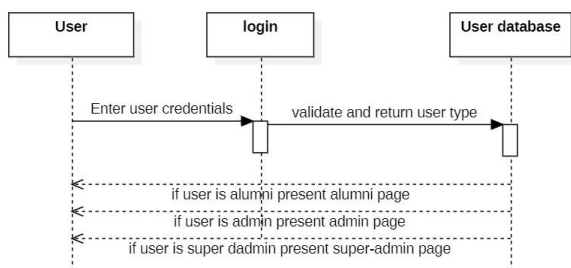

After making a user registration system we will start working on layout and physical design for different users and try to enrich it with the best possible features available right now.

During User registration system we will have email verification modules which verify user email address for the sake of genuinely along with user Email validation, there is phone number validation, ERN no validation and Username validation so that every user should have unique value stored in the database.

Login System will accept Email Id and password and then it detects user type and redirect to concerned system which is alumni or admin or super-admin system from there every user have different functionality to access.

Below is the use case diagram which will give brief how our portal will look for different user paragraph.

Figure 3.2: Use-Case Diagram

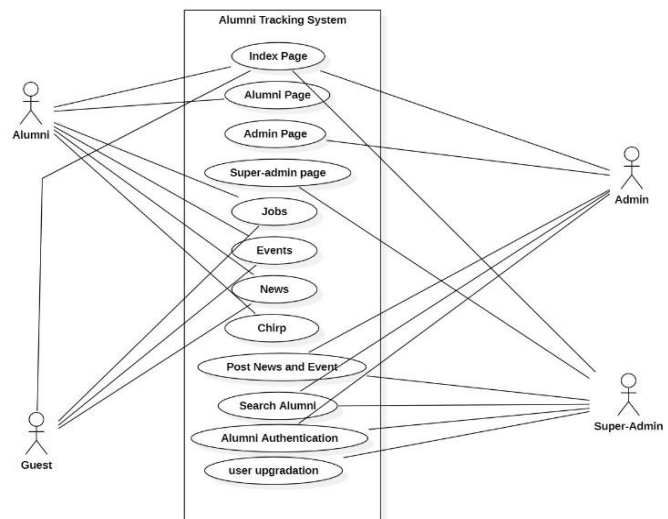

The user can update their details anytime. We will design the database system through which a smooth function of data will happen among each other.

An admin can publish an event and news and even delete and all this happen because of database system.

An admin can verify user and this also happen because of database system.

A super admin can change user type it also happens because of database system below is the ER diagram through which we can understand all the key things

Figure 3.3: Entity-Relationship Diagram

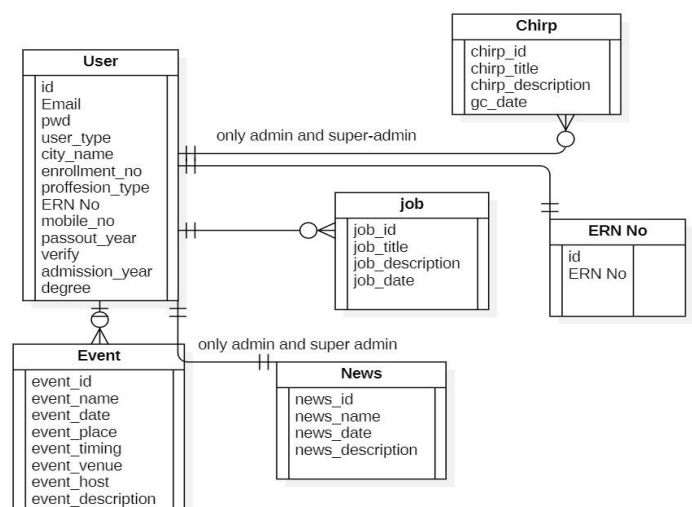

We are going to develop a search alumni features in which it scans the user database and returns all the relevant information.

There will be having a login system before displaying anything we will have a middleware which is going to detect which user is logging in accordingly it will show results. For example; admin it will show admin panel and for alumni it will show alumni related panel for this refer figure 3.1.

We will develop a process through which admin can publish notice news and everything in portal.

Admin can verify the user for it refer fig 3.3 and fig 3.4, Super admin can change the user type of user and for that we will develop a process which made required changes in database for that refer figure 3.4.

platform for alumni to increase the communication between alumni, teachers and students and promote the combination of industry, university and research. Next, through the intelligent technology of data acquisition and storage, the system achieves the effective collection of mass alumni data based on "multi-platform", the optimization of alumni management process and the extension of alumni information collection channels. In short, colleges and universities should fully mine and use alumni resources to maximize its function through the integrated intelligence alumni information management system.

5. Acknowledgement

We have taken efforts in this application. However, it would not have been possible without the kind support and help of our institution which provided data for this project. We are highly indebted to Prof Rajesh Gaikwad for his guidance and constant supervision as well as for providing necessary information regarding the application and also his support in completing the project. The authors are thankful and gratefully acknowledge all reviewers for their valuable suggestions for enriching the quality of the paper.

REFERENCES

- [1] D Yang, Research on Alumni Resources' Effect in Colleges and Universities Development. Value Engineering, 8(2013)975-975 (in Chinese).
- [2] X.D Lei, Role of Alumni Resources in the Development of Colleges and Universities. Journal of Fujian Institute of Education, 11(2010)24-26 (in Chinese).
- [3] N Rubens, M Russell and R Perez, J. Huhtamaki, Still, K., Kaplan, D. and Okamoto, T. Alumni network analysis. Global Engineering Education Conference, (2011) 606-611.
- [4] K.J Dochen, The University of Texas Elementary School : designing an alumni tracking system. (2012).
- [5] G.O Moden, W.A. Michael, Applying alumni research to decision making. New Directions for Institutional Research, 1988(2010)67-76.
- [6] H Chi, E.L Jones and L.P Grandham, Enhancing mentoring between alumni and students via smart alumni system. procedia computer science, 9(2012)1390-1399.
- [7] S Hall, Educational ties, social capital and the translocal (re)production of MBA alumni networks. Global Networks, 11 (2011)118-138.
- [8] Kowalik, E Engaging alumni and prospective students through social media. Cutting-Edge Technologies in Higher Education, 2(2011)211-227.

Figure 3.4: Process Diagram

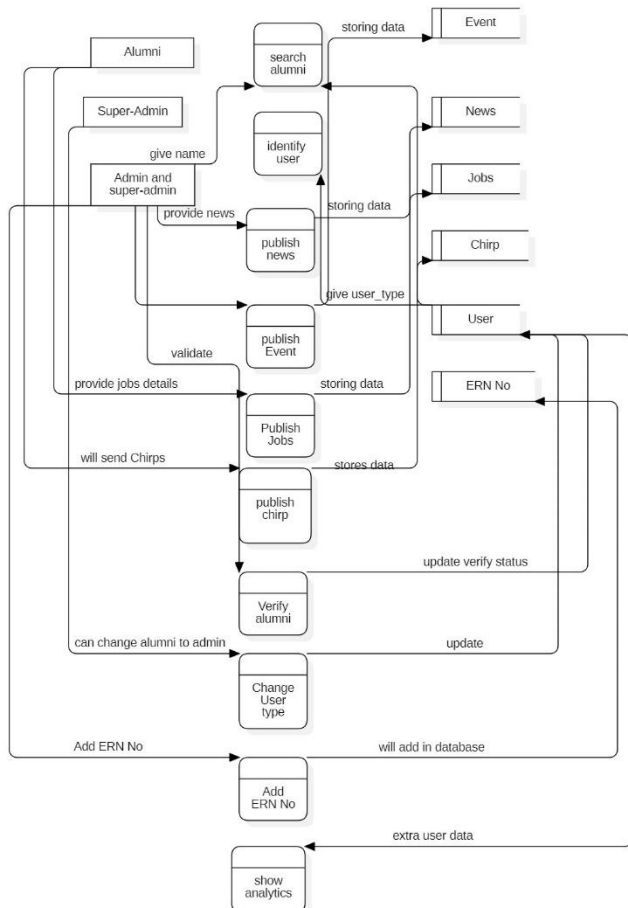

4. CONCLUSIONS

More and more colleges and universities focus on how to effectively develop and use alumni resources. Combining the problems of alumni management in "Internet+" era, this paper presents an integrated intelligent alumni information management system that implements three breakthroughs. Firstly, build a dedicated communication social networking