

Design and Analysis of Roller Frame of Less Effort Bicycle

Pushkar Bahulekar¹, Mrs. Shinde M.Y²

¹PG Student(M.Tech),K.B.P.C.O.E, Satara, Maharashtra affiliated to Dr. Babasaheb Ambedkar Technological University, Lonere, Maharashtra, India.

²Associate Professor, Mechanical Engineering Department K.B.P.C.O.E, Satara, Maharashtra

Abstract – Bicycle plays an important role in our life. It is one of the most economic transport in all over the world. but Now a days people are using bicycle only for exercising and as sport tool not for transportation. The new developments have been coming in the designing of bicycle. To reduce the weight and increase the strength of the bicycle and minimum driving effort more amount of research is going on. we designed a new concept of bicycle. In our designed bicycle roller frames is main load carrier in the our bicycle. By optimizing the design parameters of the frame will improve the bicycle performance. The optimum design will reduce effort to drive bicycle & the weight of the bicycle and increase the strength. In this paper a new design has been developed for the bicycle roller frame. The shape of the roller frame is consist of two c-channel and this connected each other by pipes at three point. The model were designed in solidworks and analysed in ansys. Finally, the analysed roller frames are then optimized to reduce weight without affecting their capacity to be resistant to mechanical stresses.

Key Words : less effort, strength, composite material, Design Optimization, FEA, Modal Analysis

1. INTRODUCTION

The main purpose of this project is to design a bicycle which can run faster compared to conventional bicycles with less pedalling force i.e less effort to drive it. So to obtain the speed of 50 to 60 km/hr with minimum efforts of the rider can be achieved with the help of various techniques such as by using an electric motor to assist the pedalling force or by reducing aerodynamic drag force or by increasing the size of rear sprocket or the length of the crank (pedals) can also be increased. Due to higher gasoline costs and the increased awareness for the environmental protection cycling gets more attractive to people, which is a great development because more people using bicycles come along with less people using cars and therefore less traffic within the cities. In relation to this the infrastructure of pathways gets more important specially to enhance the cyclists comfort and safety. Cycling comfort requires smooth rolling with low energy inputs as well as a good ride quality as a synonym for few transmitted vibrations.

This paper is dedicated to develop a human powered bicycle and The main concept of this project is to fabricate a cycle using roller crank mechanism which require less effort to drive than conventional cycle available in the market. In this

cycle we used two wheels of different sizes i.e. front wheel is having smaller size than rear wheel so at the time of turning less efforts are required. Also due to use of bigger size sprocket and smaller size freewheel speed ratio is increased so less pedalling is required to cover the same distance which is covered by existing cycle which may take more effort. Design of this cycle is done by modifying the elliptical trainer motion and combining it with the functionality of a bicycle, the our Cycle delivers a high performance workout experience that closely mimics running outdoors while eliminating the impact. It provides the most comfortable, fun and efficient way to get out and stay active. This designed Cycle is perfect for anyone who wants to get a great cardiovascular workout outdoors without damaging their body. It is particularly well-suited for runners who want to enjoy a running-like experience while giving their knees and joints a break from the wear and tear caused by running. This cycle is also ideal for cyclists who want to get the experience of cycling without the discomfort caused by sitting on a conventional bike seat or riding in a hunched-over position. this Cycle is easy to ride and more stable than it looks. Riding this Cycle requires the same amount of balance as is required to ride a traditional bike or scooter. Like anything new and different, it takes some getting used to, but we've found that most people get comfortable within 10 -20sec of riding it. this Cycle is very different from a traditional bicycle. Traditional bicycles usually have a big seat with a back rest whereas it has no seat at all. The traditional bicycle rider pedals with the legs parallel to the ground while the Cycle rider's legs are perpendicular to the ground standing up and pedalling and rider stands for the whole time. The traditional bicycle rider's visibility is usually limited because they are lower to the ground making it, both harder to see them and harder for them to see around obstacles like cars, busses, trucks etc. this designed or modified a bicycle require minimum human effort to drive than require to drive regular bicycle available in market also that enables the user to travel distances up to 15-20 kilometres comfortably and without exhaustion.

2) PROCESS METHODOLOGY

This mechanical setup consist of a frame ,a handle bar, roller frame and a connecting rod. When compare to a regular bicycle our proposed model has some modification. To provide an rotating motion to the wheel with less human power when compare to an regular bicycle here we use high speed ratio ,so we modify the sprocket system and which is

kept slightly towards rear end of bicycle which helps to the person give less effort to pedal the cycle. By walking action the torque is transmitted to connecting rod then to crank and then to the sprocket and the wheels. For joining process we are using gas welding, arc welding and linear bearings are used here to give smooth rotation to the rollers, cranks, wheel hub and connecting rods.

2.1 Frame

A bicycle frame is the main component of a bicycle, onto which wheels and other components are fitted. The frame is the most essential and defining part of the cycle. The goal was to make the frame as sturdy as possible while also minimizing the weight. The two ambitions are contradicting and therefore a balanced settlement was reached. Another goal was to make the frame cost-effective and simple to produce by reducing the complexities. The material for the lower frame (base frame) is chosen to be **AISI 1018 Mild/Low Carbon Steel**. This material is suitable for our purpose as it has excellent weld ability, and produces a uniform and hard case.

2.2 Connecting Rod

A rod or bar for transmitting motion, especially one that connects a rotating part to a reciprocating part. Such a rod that connects the piston to the crankshaft in an internal combustion engine or reciprocating pump. See also big end, little end. A connecting rod may also convert rotating motion into reciprocating motion, its original use. Earlier mechanisms, such as the chain, could only impart pulling motion. Being rigid, a connecting rod may transmit either push or pull, allowing the rod to rotate the crank through both halves of a revolution. In this cycle connecting rod used to connect one end of crank of rear sprocket & C-clamp which hold roller wheels, when force is applied on the on connecting rod by foot of rider rod transfer reciprocation motion of c-clamp i.e. roller wheel over the frame i.e. on guide way.to rotary motion of crank of rear sprocket then to rear wheel. Two AISI 1018 Mild-Low Carbon Steel pipes are used to make the connecting rod. The structure includes two bends which were made using standard pipe-bending equipment.

2.3 Wheel

A bicycle wheel is a wheel, most commonly a wire wheel, designed for a bicycle. A pair is often called a wheel set .wheels are used in this bicycle are having two different size instead of two same size wheel as in regular . after the calculations Bicycle wheels are typically designed to fit into the frame and fork via dropouts, and hold bicycle tires. A typical modern wheel has a metal hub, wire tension spokes and a metal or carbon fibre rim which holds a pneumatic rubber tire.

2.4 Roller Frame

It is a main component of bicycle on which roller rolls on application of force on connecting rod .due to rolling of rollers on frame it transmit reciprocating motion to connecting rod and then to crank and then to sprocket and then rear wheel. It is a two C section connected each other at three point and then at centre to main frame. Roller frame fitted in such angle to reduce power requirement. And also no force to back word movement of rollers.

3) RESULT AND DISCUSSION

3.1 Design

As we studied in four bar mechanism in which stroke is two times of crank radius. By keeping human comfort during driving this cycle we decided to use stroke of 500mm, if we taken stroke greater than 500mm then its very difficult to stretch the human legs greater than 500mm and if we taken stroke less than 500mm then for covering the same distance we have to pedal more times, so 500mm stroke is comfortable. After doing lots of calculations we have selected 500mm as stroke length. We kept 75mm extra length from both the sides i.e. From inner dead centre and outer dead centre for providing extra support to rolling purpose. Total length of roller frame is 650mm. We produce U-Groove of 8mm radius on roller because roller is going to roll on 16mm diameter guide pipe. That 16mm diameter pipe is welded inside the roller frame throughout 65mm.As we used guide pipe there is no contact between roller and inside surface of rolling frame in this we proceeding to our aim of minimizing human effort. Again during selecting width of roller frame we considered human comfort, man can easily stretch their legs up to 350 to 380mm by keeping this in mind and by considering the problems in manufacturing we fitted the crank at such a position on shaft such that human legs can stretch up to 320 mm

3.2Material selection

The material chosen for the frame is of utmost important as it is a major weight bearing part and has to sustain heavy vertical loading and centrifugal forces. Inspired from the chassis of formula student cars, the material for the lower frame (base frame) is chosen to be AISI 1018 Mild/Low Carbon Steel. Two AISI 1018 Mild-Low Carbon Steel c section are used to make the roller frame. And this section connected each other by three AISI 1018 Mild-Low Carbon Steel pipe. This material is suitable for our purpose as it has excellent weld ability, and produces a uniform and hard case. It is ductile and thus it is possible to bend the material pipes as per our requirement. Also, drilling is possible to make holes for mounting the other parts.

3.3 CAD Model

Figures 1 show the isometric view of the final CAD model of the roller frame created after multiple iterations and improvements.

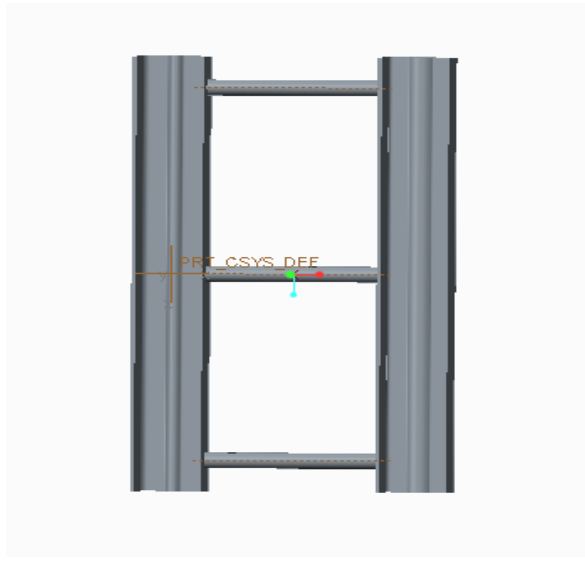

Figure 1 CAD model of Roller Frame

3.4 Analysis

The roller frame was model in SolidWorks and analysis was carried in two method 1) analytical 2) in ANSYS for the loading conditions: 1) Vertical loading The results were then used to predict whether the roller frame will be safe or not for a given rider according to his/her weight. The factor of safety was then incorporated to set a maximum weight limit for the vehicle derived from the analysis results.

The material model used for both the analyses is given in Table

Table -1: The material model used for both the analysis

Tensile Strength	440 MPa
Yield Strength	370 MPa
Modulus of Elasticity	205 GPa
Shear Modulus	80 GPa
Poisson's Ratio	0.29
Density	7.87 g/cm ³

Vertical Loading:

The first analysis is carried out with a vertical downward loading (shown by red arrow) of 1373.3 N (approximately equal to 140 kg user weight). The load is given at the centre of rod mounting point. The user weight has been taken as such a large number for extreme analysis purposes only. The

cycle is stationary during the loading and the wheel mounting points have been set to no vertical motion boundary condition. The result from this analysis gives out a maximum equivalent stress of 30 N/mm² or 30 MPa. Which suggests that the frame is rigid enough and would not undergo any yielding or plastic deformation at this load in the vertical direction.

A) Stress Analysis Calculations

Bending stress going to act on the connecting rod

So according to Flexural formula

$$\frac{\sigma}{y} = \frac{M}{I} = \frac{E}{R}$$

Where,

σ = Bending Stress

M = Bending Moment

I = Moment of Inertia about neutral axis

E = Young's Modulus

R = radius of curvature

y = Distance from neutral axis where we wants to find bending stress

According to,

$$\frac{\sigma_{Max.}}{y} = \frac{M_{Max.}}{I} \dots\dots\dots (1)$$

Here, $M_{Max.}$ = Max. Bending moment for point load = $\frac{WL}{4}$

$$\sigma_{Max.} = \frac{M_{Max.} * \bar{Y}}{I}$$

Where

$$\bar{y} = b - \frac{2 * b^2 * s + ht^2}{2bd - 2h(b - t)}$$

$$\bar{Y} = 110 - \frac{2 * 110^2 * 10 + 30 * 10^2}{2 * 110 * 80 - 2 * 60 * (110 - 10)} = 44.285 \text{mm}$$

$$I = \frac{2sb^3 + ht^3}{3} - A(b - y)^2$$

$$I = \frac{223.17 * 10^3 * 55}{423 * 10^3}$$

$$= 29.01 \text{MPa}$$

where

$$M_{max} = \frac{W * L}{4}$$

$$M_{max} = \frac{70 * 9.81 * 650}{4}$$

$$M_{max} = 223.17 * 10^3 \text{ mm}$$

Where,

$$A = bd - h(b-t)$$

$$A = 110 * 80 - 60(110 - 10) = 2800 \text{ mm}^2$$

$$\sigma_{Max} = 29.01 \text{ MPa.}$$

Yield stress for AISI 1018 = 370 MPa

So, $\sigma_{Max} < 370 \text{ MPa.}$

∴ **Design of roller frame is safe.**

B) analysis by ansys

Then we find out total deformation & von-misses stress. After applying load on connecting rod we conclude that designed roller frame can able to sustain this weight without breaking. ansys figures given below.

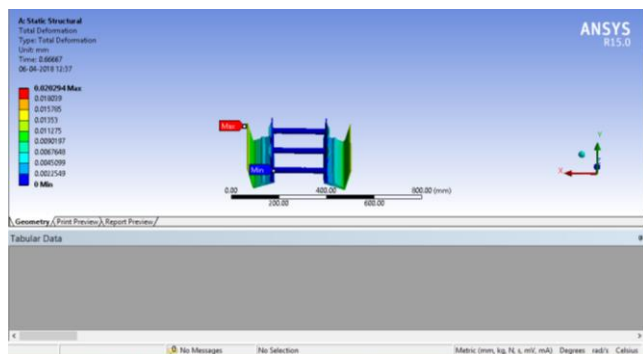

Fig.2 Total Deformation

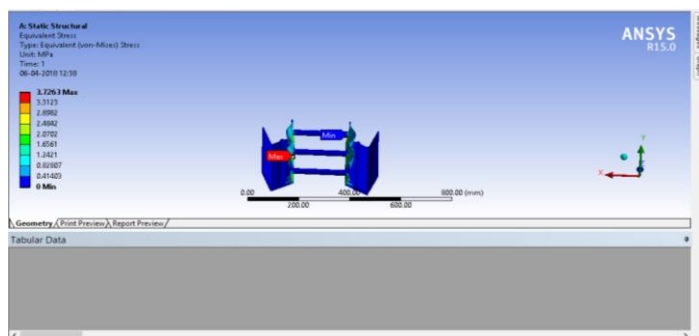

Fig.3 Von-Mises Stress Analysis

4) CONCLUSIONS

This project work has provided us an excellent opportunity and experience, to use our limited knowledge. Thus we conclude that our cycle is designed and fabricated with the 80% cost optimization hence satisfying our aim of the project which was to design and fabricate the model while optimizing the cost which is successfully achieved with an added advantage of introducing this concept in the Indian market. Our cycle is designed in such a way that we have also achieved weight optimization up to 1-3 kg. We gained a lot of practical knowledge regarding, planning, purchasing, assembling and machining while doing this project work. We feel that the project work is a good solution to bridge the gates between institution and industries. We are proud that we have completed the work with the limited time successfully. The “design and fabrication of less effort bicycle” is working with satisfactory conditions. We are able to understand the difficulties in maintaining the tolerances and also quality. We have done to our ability and skill making maximum use of available facilities. In conclusion remarks of our project work, let us add a few more lines about our impression project work. Thus we have developed a “design and fabrication of less effort bicycle” which helps to know how to achieve low cost automation. The operating procedure of this system is very simple, so any person can operate. By using more techniques, they can be modified and developed according to the applications.

REFERENCES

1. Van der Plaas R. Rolling Resistance of bicycle tires. Bike Tech 1983; 2:8-12.
2. Wang E, Macedo V, Reid J. A method for quantifying rolling resistance of bicycle tires. In: Hubbard M, Mehta RD, Pallis JM, editors. The engineering of sport 5, Vol. 2. Sheffield: International Sports Engineering association; 2004, p. 132–138.
3. Hill B. Measurement of rolling resistance using an eccentrically weighted oscillating wheel. First international symposium on surface characteristics, State College, PA; 1990.
4. Henri P. Gavin, “Bicycle Wheel Spoke Patterns and Spoke Fatigue”, ASCE Journal of Engineering Mechanics, vol 122, no. 8, (August 1996) pp. 736–742
5. Peveler, W.W., Pounders, J.D., Bishop, P.A., 2007. Effects of saddle height on anaerobic power production in cycling.
6. David Stevens, “The Stability and Handling Characteristics of Bicycles”, The University of New South Wales, School of Mechanical and Manufacturing Engineering.
7. J Astrom, K.J., Klein, R.E. & Lennartsson, A. 2005, “Bicycle dynamics and control: Adapted bicycles for education and research”. IEEE Control Systems Magazine 25(4), 26–47.

8. Kooijman J. D., Schwab, A.L., J.P. Meijaard, J.P., 2006. "Experimental Validation of a Model for the Motion of an Uncontrolled Bicycle", *MultibodySystDyn* (2008) 19:115–132, Springer Science+Business Media, Inc. 29
9. J Derek Covilla, Steven Begga, Eddy Eltona, Mark Milnea, Richard Morrissa, Tim Katza, –Parametric finite element analysis of bicycle frame geometries||, School of Computing, Engineering and Mathematics, University of Brighton, Lewes Rd, Brighton, BN2 4GJ, UK, April 2014.
10. David Stevens, –The Stability and Handling Characteristics of Bicycles||, The University of New South Wales, School of Mechanical and Manufacturing Engineering, June 2009.
11. David E.H. Jones, –The Stability of the bicycle||, Feature Article. From the Archives, September 2006.

BIOGRAPHIES



Pushkar milind bahulekar ,he is graduate student and pursuing M.tech in mechanical engineering in D.B.A.T. University