

# VIOLENCE ALERT SYSTEM TO THE POLICE USING GSM AND GPS WITH THE HELP OF MATLAB

Mr.L.Ashok Kumar<sup>1</sup>, B.Prathiba<sup>2</sup>, S.Reena Meyyammai<sup>3</sup>

<sup>1</sup>Associate Professor, Dept. of ECE, Panimalar Institute of Technology, Tamil Nadu, India

<sup>2</sup>UG Scholar, Dept. of ECE, Panimalar Institute of Technology, Tamil Nadu, India

<sup>3</sup>UG Scholar, Dept. of ECE, Panimalar Institute of Technology, Tamil Nadu, India

\*\*\*

**Abstract:** Human security against violence is one of the major concern in sensitive areas like ATMs, Government offices, Hospitals etc. For such incidents, there is a need of generating timely and automated alerts to concern officials to take further action. For this, surveillance cameras deployed in sensitive areas can be very much helpful. However, existing systems face the problems of low accuracy, high false alerts and high computational cost in monitoring and analyzing the data set images from surveillance cameras and making the decision about violence in real-time. In this paper, we propose an efficient framework to detect violence in sensitive areas using feasible computer vision and machine learning techniques. It collects the images of human activities and generates the violence related features by applying motion tracking which slices the image frames based on the presence of moving objects. To find the violent flow descriptors, it calculates the optical flow for each pixel of the frame. These violent flow descriptors are applied to different machine learning techniques to detect the violence events.

**Key Words:** GSM, GPS, LCD, Buzzer, Arduino UNO

## 1. INTRODUCTION

The aim of our project to inform about the violence in the public places to the police using GPS and GSM technology. In Real time scenario violence will not be known to the police immediately. So, by using GPS and GSM the image can be sent to the police immediately in this system, we use ARDUINO MEGA (ATmega2560) microcontroller which acts as brain of the system, because the entire system program instruction stored in it. Using image processing, the redefined dataset images are trained in the MATLAB. If the violence image is execute, then the alert message is sent to the police authorities about the violence with the location using GPS and GSM. All operations displayed on LCD and Buzzer alarm is given to alert the people nearby the violence

## 2. LITERATURE SURVEY

PiyushVashistha, CharulBhatnagar, There are different varieties of Surveillance cameras used but it is still a challenge to detect violence. So, the aim is to design a violence detection system which detects violence and generates an alert so that help will be understanding for

detecting violence. By using feature extraction process key features (speed, direction, centroid and dimensions) are identified. These features help to track object in video frame. In our approach, we consider two feature vectors namely Violent Flows (ViF) and Local Binary Pattern(LBP) and then Linear SVM is used to classify video as violent or non-violence.

## 3. PROPOSED SYSTEM

In this proposed system, we are using image processing for detect the violence with help of MATLAB. Violence occur, alert message and location will be sent through GSM&GPS.

## 4. BLOCK DIAGRAM

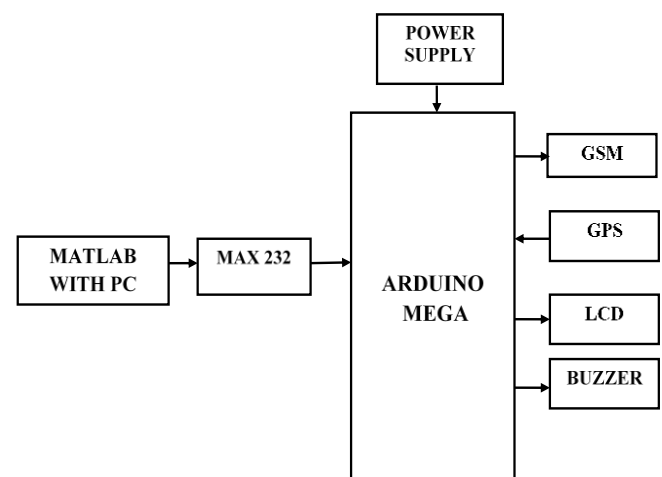

## 5. HARDWARE DESCRIPTION

### 5.1 ARDUINO UNO

The UNO is the best board to get started with electronics and coding. If this is your first experience tinkering with the platform, the UNO is the most robust board you can start playing with. The UNO is the most used and documented board of the whole Arduino family. Arduino Uno is a microcontroller board based on the ATmega328P

(datasheet). It has 14 digital input/output pins (of which 6 can be used as PWM outputs), 6 analog inputs, a 16 MHz quartz crystal, a USB connection, a power jack, an ICSP header and a reset button. It contains everything needed to support the microcontroller; simply connect it to a computer with a USB cable or power it with a AC-to-DC adapter or battery to get started. You can tinker with your UNO without worrying.

## 5.2 BUZZER

A buzzer or beeper is an audio signaling device, which may be mechanical, electromechanical, or piezoelectric (piezo for short). Typical uses of buzzers and beepers include alarm devices, timers, and confirmation of user input such as a mouse click or **keystroke**

## 5.3 GSM

The evolution of cellular telecommunications, various systems have been developed without the benefit of standardized specifications. This presented many problems directly related to compatibility, especially with the development of digital radio technology. The GSM standard is intended to address these problems. GSM provides recommendations, not requirements. The GSM specifications define the functions and interface requirements in detail but do not address the hardware. The reason for this is to limit the designers as little as possible but still to make it possible for the operators to buy equipment from different suppliers. The GSM network is divided into three major systems: the switching system (SS), the base station system (BSS), and the operation and support system (OSS).

## 5.4 GPS

GPS satellites circle the Earth twice a day in a precise orbit. Each satellite transmits a unique signal and orbital parameters that allow GPS devices to decode and compute the precise location of the satellite. GPS receivers use this information and trilateration to calculate a user's exact location. Essentially, the GPS receiver measures the distance to each satellite by the amount of time it takes to receive a transmitted signal. With distance measurements from a few more satellites, the receiver can determine a user's position and display it electronically to measure your running route, map a golf course, find a way home or adventure anywhere. To calculate your 2-D position (latitude and longitude) and track movement, a GPS receiver must be locked on to the signal of at least 3 satellites.

## 5.5 LCD

LCD screen is an electronic display module and find a wide range of applications. A 16x2 LCD display is very basic module and is very commonly used in various devices and

circuits. These modules are preferred over seven segments and other multi segment LEDs. A **16x2 LCD** means it can display 16 characters per line and there are 2 such lines. In this LCD each character is displayed in 5x7 pixel matrix. This LCD has two registers, namely, Command and Data. The command register stores the command instructions given to the LCD.

## 6. SOFTWARE REQUIREMENTS

### 6.1 ARDUINO IDE

Arduino IDE is associate degree ASCII text file computer code that's principally used for assembling and writing the code in audio module. It contains of text console, a message space, and text editor for writing code. It consists of toolbar with buttons for common functions and a series of menus. It's a crossplatform application that's written in functions from C and C++. The Arduino IDE employs the program avrdude to convert the possible code into a computer file in positional notation secret writing that's loaded into the Arduino board by a loader program within the board's code.

### 6.2 EMBEDDED C

Embedded C Programming is that the soul of the processor functioning within every and each embedded system like mobile phones, laundry machines etc. The embedded device is controlled with the assistance of Associate in Nursing embedded computer programme. In microcontroller Embedded C language is usually usually used.

## 7. IMPLEMENTATION

The aim of our project is to protect the lives of human being and to avoid the violence. If any violence occurs immediate action by police will be taken and by using GSM and GPS, the police would easily track the address.

## 8. RESULTS

The basic concepts of Embedded system, MATLAB and Implementation of violence alert system using GSM and GPS with the help of MATLAB have been discussed. We can see that the algorithm writes perfectly .By using KNN Algorithm machine learning, violence and Non- violence images are trained using MATLAB program. When violence occurs location and data will be send to police using GSM and GPS. We took a paper as our existing concept and proposed system is to reduce the loss of human lives and time taken

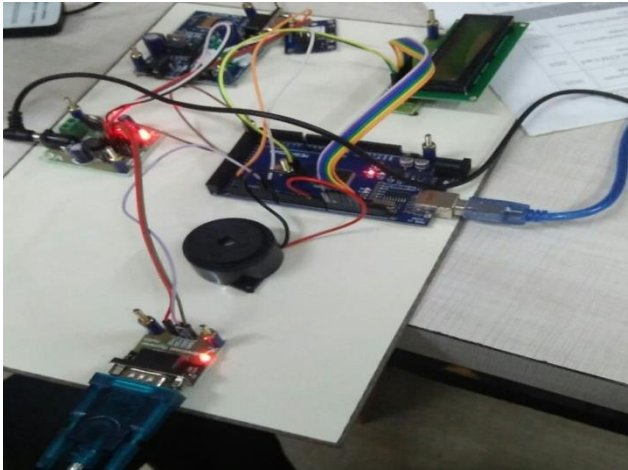

[7] E. Acar, F. Hopfgartner, and S. Albayrak, "Violence detection in hollywood movies by the fusion of visual and mid-level audio cues," in Proceedings of the 21st ACM international conference on Multimedia, pp. 717-720, ACM, 2013.

[8] S. J. Blunsden and R. B. Fisher, "Pre-fight detection classification of fighting situations using heirachicaladaboost," 2009.

## 9. CONCLUSIONS

Thus our proposed system is highly suitable for time reduced to protect the people and no losses of human life.

It is highly effective, to inform to the police about the violence in the public places.

By using Image processing we detect whether it is violence or non-violence.

## 10. REFERENCES

[1] A. Datta, M. Shah, and N. D. V. Lobo, "Person-on-person violence detection in video data," in Pattern Recognition, 2002.Proceedings.16th International Conference on, vol. 1, pp. 433-438, IEEE, 2002.

[2] E. B. Nieves, O. D. Suarez, G. B. Garc'ia, and R. Sukthankar, "Violence detection in video using computer vision techniques," in International conference on Computer analysis of images and patterns, pp. 332-339, Springer, 2011.

[3] Y. Chen, L. Zhang, B. Lin, Y. Xu, and X. Ren, "Fighting detection based on optical flow context histogram," in Innovations in Bio-inspired Computing and Applications (IBICA), 2011 Second International Conference on, pp. 95-98, IEEE, 2011.

[4] I. S. Gracia, O. D. Suarez, G. B. Garcia, and T.-K. Kim, "Fast fight detection," PloS one, vol. 10, no. 4, p. e0120448, 2015.

[5] O. Deniz, I. Serrano, G. Bueno, and T.-K. Kim, "Fast violence detection in video," in Computer Vision Theory and Applications (VISAPP), 2014 International Conference on, vol. 2, pp. 478-485, IEEE, 2014.

[6] E. Y. Fu, H. V. Leong, G. Ngai, and S. C. Chan, "Automatic fight detection in surveillance videos," International Journal of Pervasive Computing and Communications, vol. 13, no. 2, 2017.