

# Web App Controlled SPY Robot with Various Application

Anuj Sharma<sup>1</sup>, Rishabh Dubey<sup>2</sup>, Prof. Preeti Singh<sup>3</sup>

*<sup>1-3</sup>Department of Electrical Engineering, Medicaps University, Indore*

\*\*\*

**ABSTRACT:** 20th century known for century of full of automation and development. We see day to day life automation become habit of every field like manufacturing industries, automobile industries, farming etc.

We are introducing IoT based solar grass cutter. IoT is a system of interrelated digital machine mechanical and people that are used to data in efficient way. In IOT based solar cutter, controls are made by Smartphone which is become a use of everyone . Solar panels become source of solar energy giving the energy to the system. This renewable source of energy is used in summer and other season also.

## INTRODUCTION

The basic idea behind the Bluetooth based solar grass cutter is the reduced human efforts and to take another step forward towards the automation by improving all the machines around us from manual usability to automatic use of them.

- ▶ In this project we have designed IOT based grass cutter that eliminated the need of physical power. And used for spying as well as gardening.
- ▶ This project is an autonomous that will allow the user to the ability to cut their grass with minimal effort. Unlike other robotic grass cutter on the market, this design requires no perimeter wires to maintain the robot within the grass.

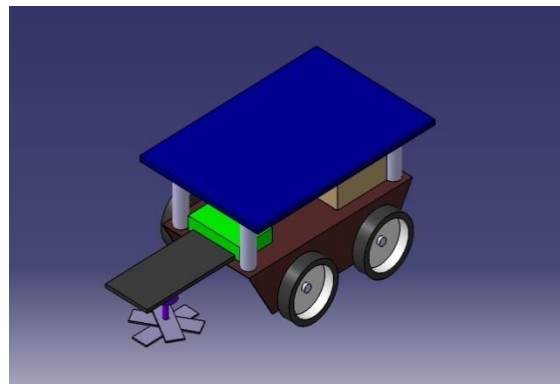

## LITERATURE REVIEW

[1] The combination of IOT and solar based robot is rarely found in related research literature.

[2] This may be attributed to the fact that solar grass cutter are complex embedded system requiring expertise in embedded software and hardware.

[3] However, this proposal includes a server to facilitate the connections between the users Smartphone and the grass cutter in order to exchange data and user commands.

[4] Ms. Bhagyashri R. Patil, Mr. Sagar S. Patil: discussed that human involvement is necessary in every field of working area. The purpose shows to use the solar energy which is renewable form to move the robot with minimal effort of human interaction.

[5] M. A. Miskam et al in had developed an Android application as a simple tool to empower non-technical persons in using robots to interact with children with autism for learning and therapeutic purposes. The main problem is that in order this

project to work, both NAO and an Android device has to be on the same router. Furthermore, their Android application has minimum controllability over the humanoid robot.

**BLOCK DIAGRAM DISCRPTION**

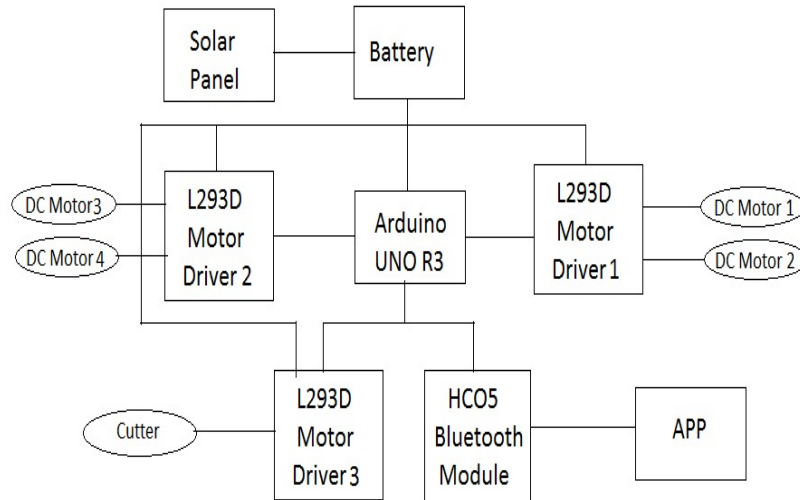

**WORKING**

In the era of modern world, automation is important. For this, we have design a system which limits the manpower and use minimum energy with minimal effort to cut the grass. Iot links mechanical devices to the digital machines.

System has four wheels, solar panel, battery, Arduino, DC motor, Bluetooth module and the cutter, assembled together to cut the grass. It is operated via mobile phone using Bluetooth app as per the need.

First, in the Android App, I have used 5 keys as Forward, Reverse, Left, Right and Stop. The corresponding data associated with each key is as follows:

- 1- ON
- 2- OFF
- 3- Forward
- 4- Reverse
- 5- Left
- 6- Right

When a particular key is pressed, the given instruction is transmitted to the Bluetooth module from the phone over bluetooth connection. Then Arduino receives the signal and performs the operation i.e. appropriate instruction sends to the motor driver input pins.

# DC MOTER

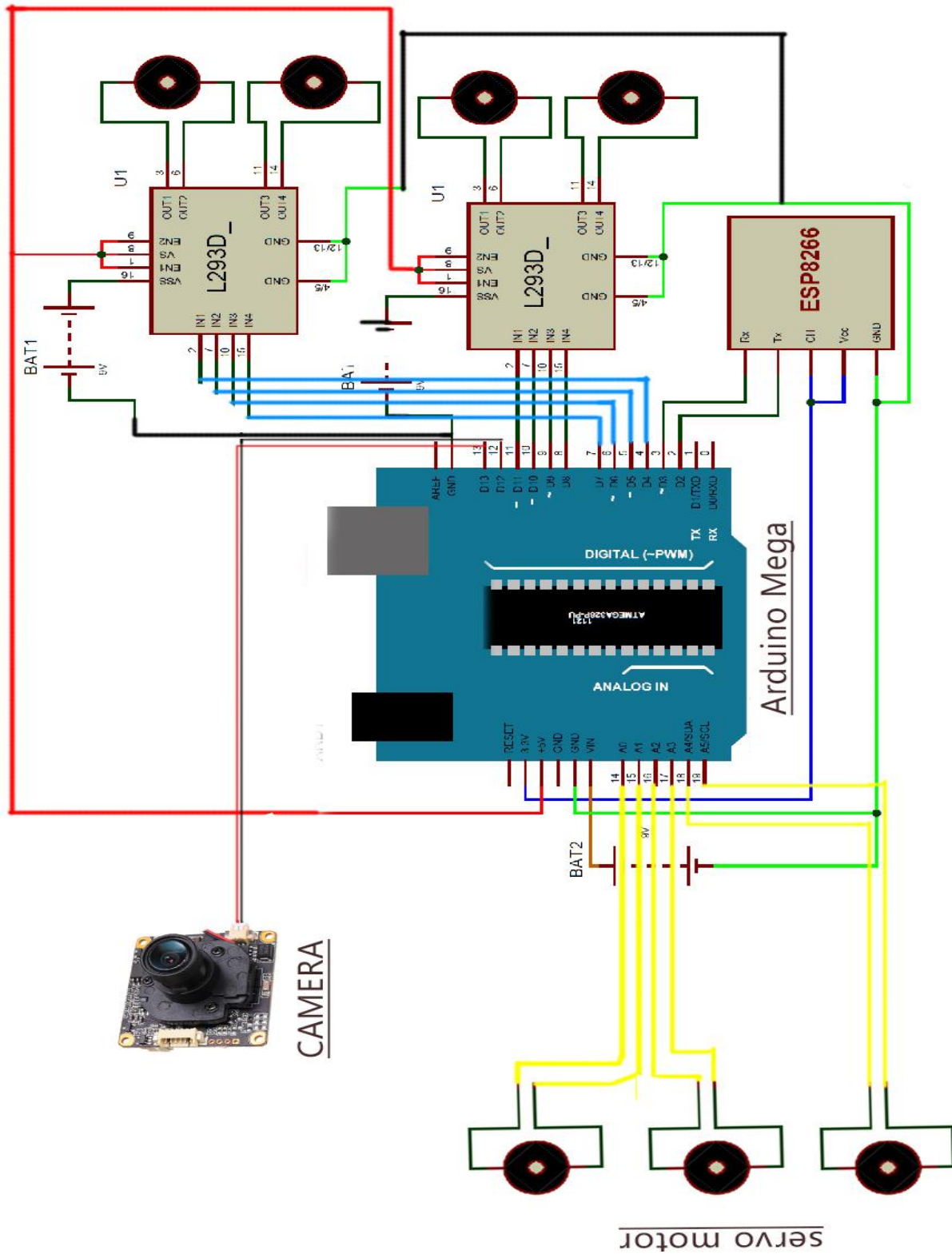

**CALCULATION**

Assuming battery is fully charged and remains same over its consumption. A11 5 motors are parallel connected with the battery source of 11 volt. A5 voltage is same in the circuit assuming 0.5 A current.

$$\text{Power} = \text{Voltage} \times \text{Current} = 11 \times 0.5 = 5.5 \text{ Watt}$$

Assuming all this power is consumed in rotating the wheel and the cutter and the power is equally divided.

TORQUE IN EACH TYRE

$$\text{TOTAL POWER} = 5.5 \text{ W}$$

$$\text{Power used in each tyre to rotate} = 5.5 / 5 = 1.1 \text{ W}$$

$$\text{AND } P = 2\pi NT / 60$$

Where N = No. of Revolution

T = Torque in tyre

P = Power consumed in tyre as per rotor specification

$$N = 500 \text{ RPM}$$

$$P = 1.1 \text{ W}$$

$$P = 2\pi NT / 60$$

$$1.1 = 2 \times \pi \times N \times T / 60$$

$$T = 0.021 \text{ N-m}$$

$$R = \text{Radius of tyre} = 1 \text{ cm} = 0.01 \text{ m}$$

F = Force acting on wheel to rotate in

$$T = F \times R$$

$$0.021 = F \times 0.01$$

$$F = 2.1 \text{ N}$$

Thus, force acting on each wheel to move the vehicle

MAXIMUM WEIGHT OF THE BODY

Taking  $\mu = 0.3$  ( $\mu$  is the coefficient of friction)

$$F = \mu N_r \text{ (} N_r \text{ is the Normal Reaction)}$$

$$2.1 = 0.3 \times N_r$$

$$N_r = 7 \text{ N}$$

$$N_r = Mg / 4$$

$$7 = M \times 9.81 / 4$$

$M=2.85 \text{ kg}$

Maximum weight of the body as well as assembly is 2.85 kg

POWER USED IN ROTATING THE CUTTER AND CALCULATING THE TORQUE REQUIRED.

Power used in rotating the cutter

$$=5.5/5=1.1W$$

$N$  = no. of revolution of cutter per minute

$$=5000\text{rpm}$$

$$P=2\pi NT/60$$

$$1.1=2\pi \times 5000 \times T/60$$

$$T=.0021N\text{-m}$$

Maximum force acting on cutter to cut the grass

$$\text{Radius of cutter}=1\text{cm}=.01\text{m}$$

Maximum force will act at outer periphery of the cutter.

$$T=F(\text{max}) \times R$$

$$.0021=f(\text{max}) \times .01$$

$$F(\text{max})=.21\text{N}$$

## COMPONENT

Following are the main components of our Bluetooth controlled solar cutter.

**1. Arduino Uno R3:** R3 is the latest version of Arduino UNO which we are using in our cutter. Recommended input voltage for this device lies between 7 to 12 voltage and limit is 6 to 20 voltage.

The function of Arduino UNO in are machines to receive signals from Bluetooth module and to control the things based on the coding which are loaded onto you from the Arduino computer programmes which can be operated very easily. It has 20 digital input and output pins for proper connection with other devices like l293d motor driver and IR sensor etc.

**2. L293d DC motor driver:** L293D is a typical Motor driver or Motor Driver IC which allows DC motor to drive on either direction. L293D is a 16-pin IC which can control a set of two DC motors simultaneously in any direction. It means that you can control two DC motor with a single L293D IC. It works on the concept of H-bridge. H-bridge is a circuit which allows the voltage to be flown in either direction. As you know voltage need to change its direction for being able to rotate the motor in clockwise or anticlockwise direction, Hence H-bridge IC are ideal for driving a DC motor. The maximum voltage for VSS motor supply is 36V. It can supply a max current of 600mA per channel. Since it can drive motors Up to 36v hence you can drive pretty big motors with this l293D

**3. HC05 Bluetooth module:** The HC05 Bluetooth module helps in transfer signals from android application to the microcontroller over the bluetooth connection.

Main motive of this Bluetooth module is to control servo motor being used in cutter with the help of Smartphone over bluetooth connection. The power supply for the module is +3.3 V and 50mA.

**4. Solar panel:** Solar panel works on the principle of photovoltaic effect. When the photons strike the surface of panel, the photovoltaics else inside solar cells convert the heat energy into electrical energy and this energy is collected in the battery and can be utilised as energy source for grass cutter.

**5. DC motors:** Here in our machine, we are using 5 servo motors. Four of them are for the four wheels mini motor is used for rotating cutters with approximate speed of 500 revolutions per minute.

It is the motor which is responsible for providing torque to the wheels for smooth and swift rotation and translation of the cutter.

**6. Battery:** It stores the electrical energy converted from solar energy with the help of solar panel fitted into the device. The capacity of the battery being used in the cutter is 12V/1.3AH.

## CONCLUSIONS

Bluetooth based solar grass cutter is the machine which not only make good uses of IOT but also based on the need of current scenario that is to minimize the dependency on renewable sources of energy. It fulfills the dual purpose of reducing human efforts as well as the use of energy source which is available in abundance.

Not only skilled but unskilled persons can also operate the device easily using an application in mobile phones and can control it in simple touch.

Although many studies have been conducted to analyze the usage and effectiveness of solar grass cutter, we still need more research in this field. As future research, the influence of incorporating a solar grass cutter robot into the Project Leonard as an assistant to care managers in order to enhance disease and care management effect must be addressed In a nutshell, it is an economical method as compared to an existing method if it is produced on large scale. Also it provides flexibility to the user controlling it.

## FUTURE REFERENCE

The modification that can be done in future in this model is to implant sensors along with the camera and with the use of artificial intelligence I, the automatic processing of surrounding can be done.

In such way, it will require a negligible interference of humans and can perform its job by overcoming any obstacle.

## REFERENCES

1. Srishti Jain, Amar Khalore, Shashikant Patil. Self-Efficient and Sustainable Solar Powered Robotic Lawn Mower in International Journal of Trend in Research and Development (IJTRD). Vol.2 (6) December 2015.
2. Ms. Rutuja A. Yadav, Ms. Nayana V. Chavan, Ms. Monika B. Patil, Prof. V .A. Mane. Automated Solar Grass Cutter in International Journal of Scientific Development and Research (IJS DR). Vol.2, February 2017.
3. Tushar Baingane. Fully Automated Solar Grass Cutter, February 2018.
4. Ms. Bhagyashri R. Patil, Mr. Sagar S. Patil. Solar Based Grass Cutting in International Journal of Electrical and Electronics Engineers (IJE EE). January-June 2017.
5. Siddhartha Wadhvani, Uday Singh, Prakash Singh, Shraddha Dwivedi. Smart Home Automation and Security system using Arduino and IoT (IRJET), February 2018.
6. Sumit Gupta, Prakhar Upadhyay, Yogendra Sharma, Sachin Kumar Dwivedi, Asst. Prof. Utkarsh Srivastava<sup>5</sup> Sumit Gupta<sup>1</sup>, Prakhar Upadhyay<sup>2</sup>, Yogendra Sharma<sup>3</sup>, Sachin Kumar Dwivedi<sup>4</sup>, Asst. Prof. Utkarsh Srivastava<sup>5</sup>. IOT BASED SOLAR GRASS CUTTER. International Research Journal of Engineering and Technology (IRJET) June 2020.