

Collision Avoidance System using Vehicle to Vehicle (V2V) Communication through Vehicular Ad Hoc Network (VANET)

Ashutosh Mudgal¹, Shivani Choudhari², Kalyani Raut³, Abhishek Joshi⁴, Yamini Dabhane⁵, Sumedh Mule⁶

¹Author Student, Department of Electronics and Telecommunication Engineering, Prof Ram Meghe Institute of Technology & Research Amravati, Maharashtra, India

^{2,3,4,5,6}Co-Author Student, Department of Electronics and Telecommunication Engineering, Prof Ram Meghe Institute of Technology & Research Amravati, Maharashtra, India

Abstract - Nowadays due to increasing in population the vehicles are also increasing and leads to accidents and traffic mismanagement on roads. The result is nearly 13.5 lakh people die in accidents and crashes that happen due to negligence and visibility conditions. In this paper, the technology proposed will work on vehicular ad hoc network by using the vehicle to vehicle communication. In this system, the antecedent vehicle will be connected to just the preceding vehicle and this preceding vehicle will be connected to the vehicle just in front of it. The connection between vehicles is done through Wi-Fi connectivity in line of sight view. Every vehicle will be installed with NodeMCU board, Wi-Fi module, LCD, ultrasonic sensor, speed sensor, DC motor (MOSFET as a motor driver), crash detection sensor, and SIM808 (GPS/GSM/GPRS/Bluetooth) module. The LCD of the antecedent vehicle will display the speed and distance of just the preceding vehicle. When the distance between two vehicles reduces to a specific limit the speed of the antecedent vehicle will be controlled by using an ultrasonic sensor and DC motor controller and reduced to avoid the collision. This technology will also maintain efficient traffic flow and capable of providing priority to emergency vehicles.

Key Words: DSRC, V2V, Ad Hoc, Collision Avoidance, Intelligent Traffic Management, VANET.

1. INTRODUCTION

In this fast-paced world, everyone nowadays demands the safest transport system. For the fast-paced world, the transport system needs to be fast enough but with no accidents and all safety. The main problem in the transport system is unorganized traffic, poor traffic management and lots of accidents, if this isn't prevented the death rate in road accidents is expected to be one of the major causes of death contributing to one-third of total deaths. As the automotive is advancing towards self-driven vehicles and automatic vehicles. Vehicle-to-vehicle communication and connected vehicles are contributing to safety and accident prevention. Our proposed system of vehicle-to-vehicle communication

through vehicular ad hoc network (VANET) is providing the solution to this problem.

In this system, two vehicles in the line of sight will communicate with each other wirelessly using Wi-Fi technology for fast data transfer between vehicles. In this prototype, vehicles are fitted with a set of NodeMCU board, Wi-Fi module, LCD 16*2, ultrasonic sensor, speed sensor, DC motor with which MOSFET is used as a motor driver, crash detection sensor, and SIM808 (GPS/GSM/GPRS/Bluetooth) module.

The speed sensor and ultrasonic sensor will measure the speed and distance between two vehicles and sends it to LCD for display as well as to microcontroller for doing calculations to control the speed and apply brakes to prevent accident and this process is done continuously. LCD will continuously display the data received from the speed sensor and ultrasonic sensor as speed and distance. If the distance between two vehicles becomes less the microcontroller will lower the speed of DC motors and apply brakes and the ultrasonic sensor also sense any other obstacle in front of the vehicle and apply brakes by lowering down the speed to prevent accidents. If this system fails to prevent accidents and apply brakes the crash detection sensor will come into action and detect the accident and send the location of the vehicle to emergency vehicles to get immediate help with the help of a GPS module.

This prototype is not designed for any specific vehicle it can be used in any vehicle irrespective of its size, brand, or model. Most it takes is little modification which differs from vehicle to vehicle and it is designed by keeping in consideration that normal cars can also use it. This suggested system is cost-effective, highly efficient, and adaptable to prevent accidents.

2. HARDWARE REQUIREMENTS

2.1 NodeMCU Board

NodeMCU is an open-source platform, its hardware design is open to editing, modifying, and building. It has 128 KB of RAM whereas flash memory is 4 megabyte to store codes, data, and programs. NodeMCU has Tensilica 32-bit RISC CPU Xtensa LX106 microcontroller. Its operating voltage is 3.3 V and input voltage 7-12 V. There are in total 16 general-purpose digital I/O (DIO) pins varying from GPIO1 to GPIO16 of which one is analog input pin (A0), UART pins (TXD0, RXD0, TXD2, RXD2), SPI pins (SD1, CMD, SD0, CLK), one I2Cs, and two control pins i.e. (EN, RST). It also has a reset button and a flash button. NodeMCU is powered via a micro-USB and there are also ground pins and external power supply pins that are GND and Vin. The board has an antenna attached to it and the clock speed is 80 MHz. The NodeMCU board is widely used because of its easy-to-use nature, handy, cost-effectiveness. ESP8266 is a widely used Wi-Fi module with a NodeMCU board and this board can be easily programmed through Arduino software.

2.2 Wi-Fi Module (ESP8266)

ESP8266 is a cost-effective Wi-Fi chip. It is mostly used with the NodeMCU board. This ESP8266 Wi-Fi module is a self-contained SOC with which the TCP/IP protocol stack is integrated and this module can give access to any of the microcontrollers of the Wi-Fi network. The ESP8266 module has a powerful onboard processing capacity and also has enough storage capability through which it allows to be integrated with devices like sensors and other application devices through the GPIO pins with minimal loading during runtime. In this prototype, ESP8266 is used with NodeMCU for establishing connectivity between two vehicles wirelessly.

2.3 LCD (16*2)

LCD is most popularly known as or full form is liquid crystal display. This LCD has 16 columns and 2 rows i.e. 16*2. There is a backlit in LCD having the colour yellowish-green and it allows optimal view in all of the lighting conditions. There are in total 16 pins in LCD 16*2 they are Vss, Vdd, Vo, RS, R/W, DB0 – DB7, A (LED+), K (LED-). The voltage drop of light emitting diode is 4.2 V. The cons of using this module are that it is cost-effective, programming this module is easy, no limit on the number of characters to be displayed. In this prototype, the LCD will display the speed and distance data received from sensors.

2.4 Ultrasonic Sensor (HC-SR04)

The HC-SR04 is popularly known as an ultrasonic sensor. The use of an ultrasonic sensor is to measure the distance and give the data to other sensors and microcontrollers for processing. There are typically 4 pins attached to the HC-SR04 sensor that are Vcc, Trigger, Echo, Ground. Voltage on which this sensor work is +5 V, the accuracy of this sensor is 3mm, and the operating current and operating frequency are less than 15mA and 40 Hz respectively. The angle covered by this ultrasonic sensor is less than or equal to 15 degrees. This sensor consists of a transmitter and receiver where transmitter send ultrasonic wave and it travels in the air and when obstructed by any obstacle or any object it gets reflected back and this is observed by the receiver for calculation of distance. This sensor works on the simple formula: Speed= Distance x Time.

2.5 Speed Sensor (LM393)

In this prototype, we have used LM393 as a speed sensor. LM393 is widely used as a speed detection sensor. There are two outputs to this sensor of which one is digital and one is analog. It works in a voltage range between 3.3 V to 5 V. It has 4 pins Vcc, GND, D0, A0. The working of this sensor is as that if anything is passed between the slots of the sensor, the digital pulse on pin D0 is created and this pulse goes between zero volts to five volts and this is a TTL signal.

2.6 DC Motor (MOSFET as motor driver)

The DC motor is known as a direct current motor which is an electrical device and runs on a direct power supply. This DC motor converts electrical type of energy to mechanical type of energy. The speed of this direct current motor is measured in terms of RPM i.e. rotation per minute, it counts that how many numbers of times the shaft is rotated in a minute. The MOSFET motor driver will act as interfacing between motors and microcontrollers. In this prototype, we have used a DC motor, and MOSFET is used as a motor driver to control the speed of this direct current motor to prevent the collision. There are two terminals in the DC motor. MOSFET will act as a current amplifier as they take a low-level current control signal and thus provides a high-level current signal. The same high-level current signal is used to drive a DC motor There are different types of DC motor like 12V motor, geared motor, etc. An STDP (single pole double throw) switch is used and when the switch is in on state that means the motor has stopped running and a brake is applied to the vehicle.

2.7 Crash Detection Sensor

A crash detection sensor is basically a limit switch and impact sensor's combination. This sensor includes a piece of electronic safety equipment that detects an impact with the help of vibrations. This is the same sensor that is used to activate emergency airbags in cars while collisions or crashes. This sensor helps to improve the safety of the transport system and thus saves human lives.

2.8 SIM808 (GPS/GSM/GPRS/Bluetooth) module

SIM808 (GPS/GSM/GPRS/Bluetooth) module is an entire Quad-Band GSM/GPRS module that combines GPS technology with it for satellite navigation. There are in total 22 tracking's and 66 acquisition receiver channels in this module and have high GPS receive sensitivity. The supply for this is in the range of 3.4 - 4.4V. The GSM/GPRS has point-to-point MO and MT, SMS cell broadcast, text, and PDU mode. It is controlled by using AT Command (3GPP TS 27.007, 27.005 and SIMCOM enhanced AT Commands). Due to compact design, integrated GPRS and GPS in an LCC package, easy to use, handy it has become a variable asset that is used to be track location easily and smoothly at any location and anytime with signal coverage.

3. SOFTWARE REQUIREMENTS

3.1 Arduino IDE

Arduino IDE refers to Arduino Integrated Development Environment. This IDE software is introduced by Arduino.cc company. It is used to write and compile codes and upload them to the physical board. Simplicity being one of the major reason for Arduino IDE to be most preferred and famous among all and other reasons are its ease of use and free availability. The IDE supports C as well as C++ language whereas embedded C remains on top. There are two basic areas of IDE one is the editor and the other is the compiler where the editor is used to write code and the compiler is used to compile and upload those codes into the board. This main code is called as the sketch and the hex file for this sketch is created and uploaded to the controller on board. Arduino IDE comes under GNU general public license i.e. available free of cost and widely used.

3.2 Embedded C Programming Language

Embedded C programming language is the most used programming language in the development of the embedded system. In between many embedded developing languages like python, assembly, C++, Ruby, etc. embedded C is most popular because of its ease of use nature, high-efficiency level, and less development time.

4. BLOCK DIAGRAM

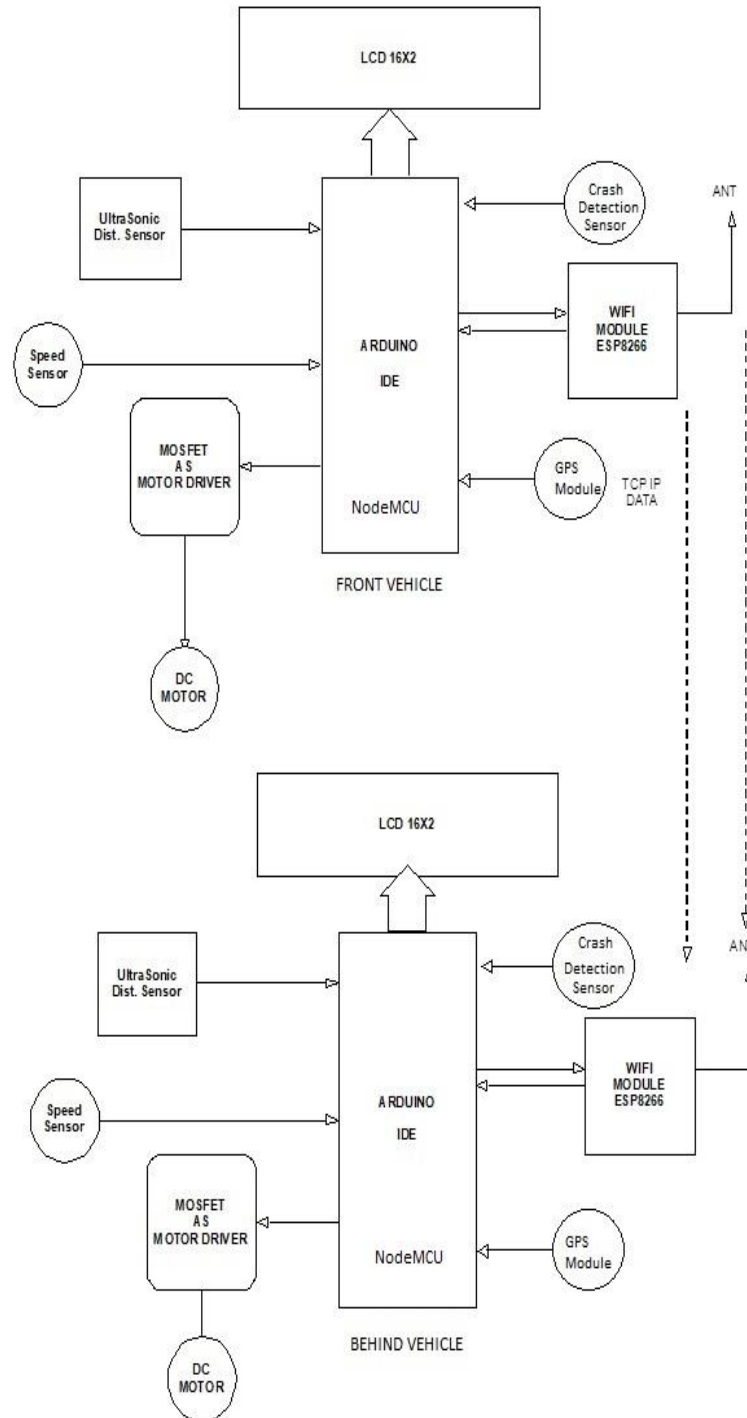

Fig -1: Block diagram of Collision Avoidance System

5. INTERFACING AND SERIAL OUTPUT

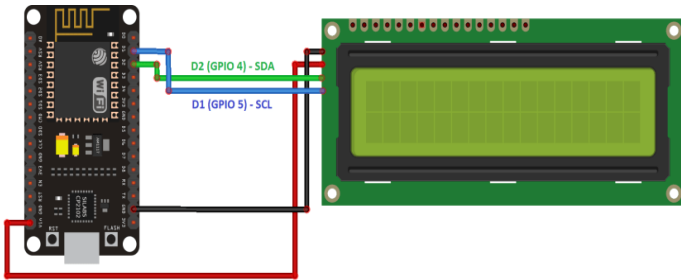

Fig -2: Interfacing of LDC with NodeMCU

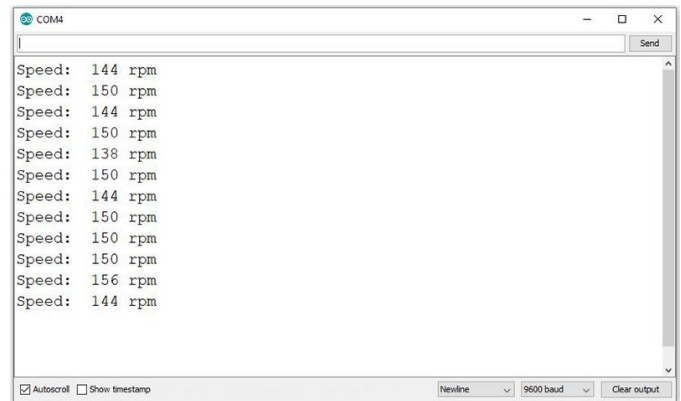

Fig -4: Interfacing and Serial Output of Speed Sensor with NodeMCU

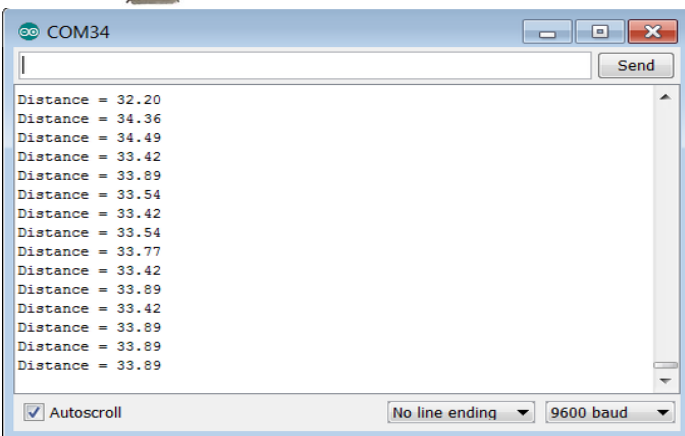
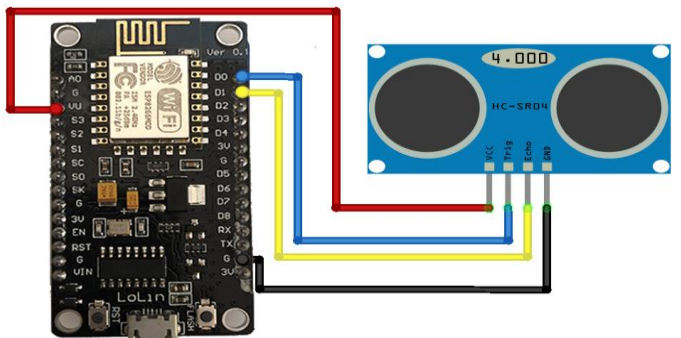

Fig -3: Interfacing and Serial Output of Ultrasonic Sensor with NodeMCU

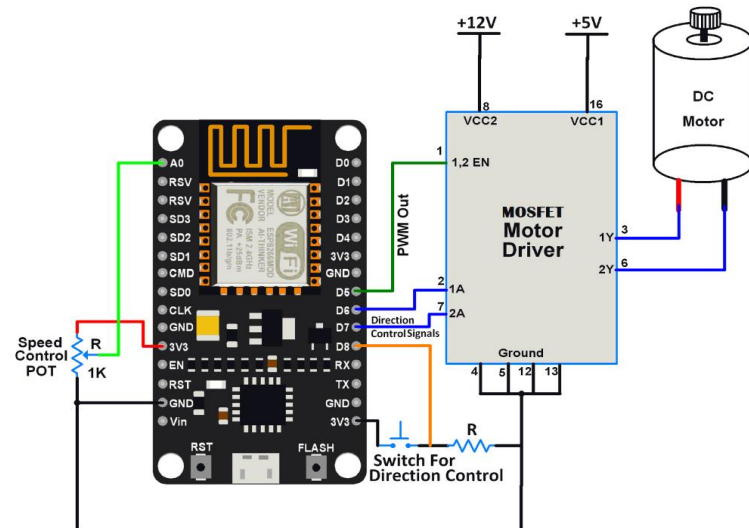

Fig -5: Interfacing of DC Motor with NodeMCU

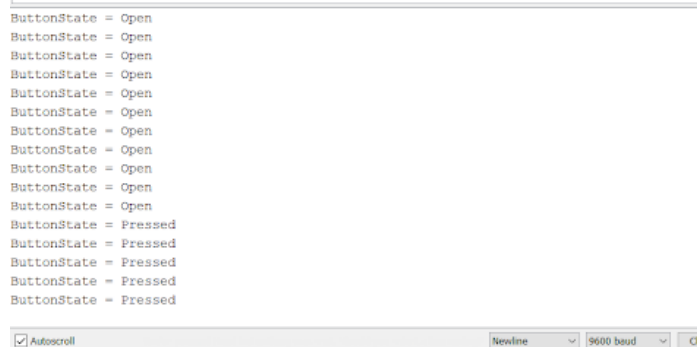
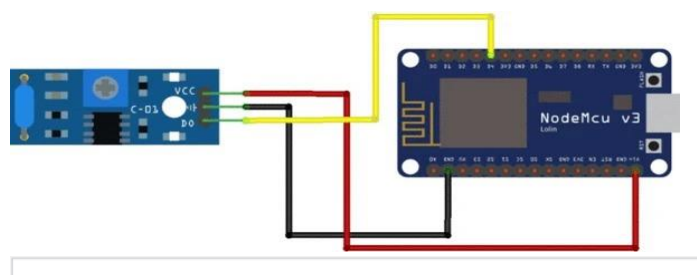
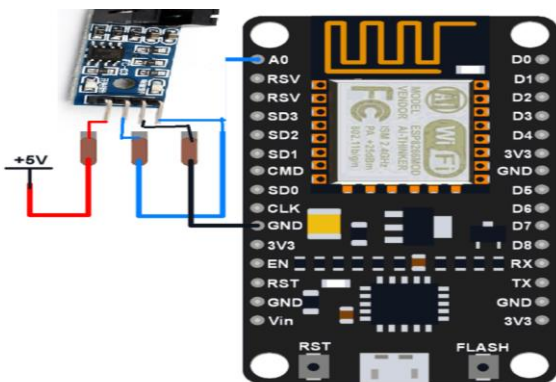

Fig -6: Interfacing and Serial Output of Crash Sensor with NodeMCU

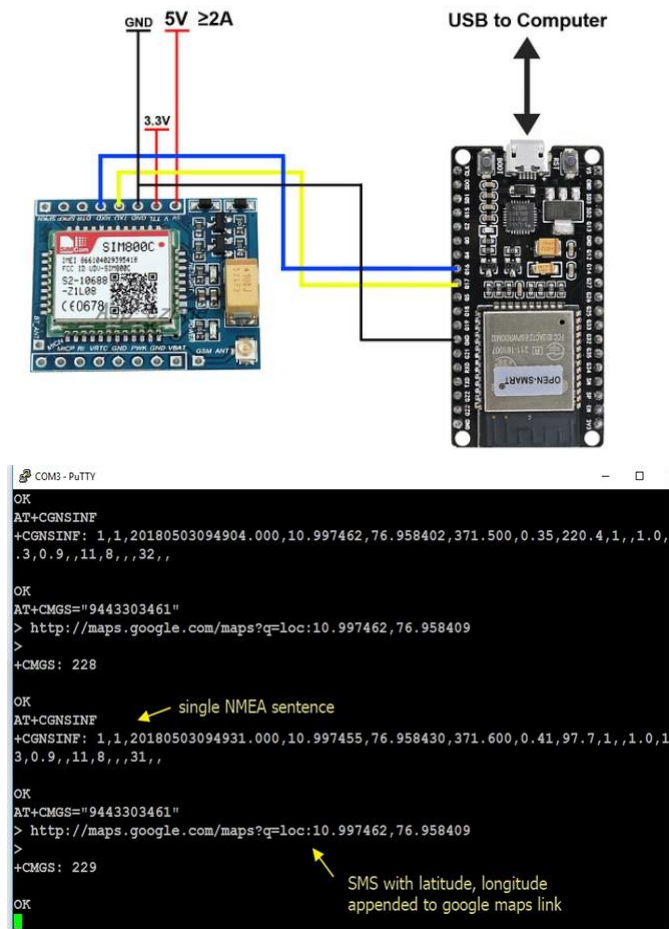

Fig -7: Interfacing and Serial Output of SIM808 (GPS/GSM/GPRS/Bluetooth) module with NodeMCU

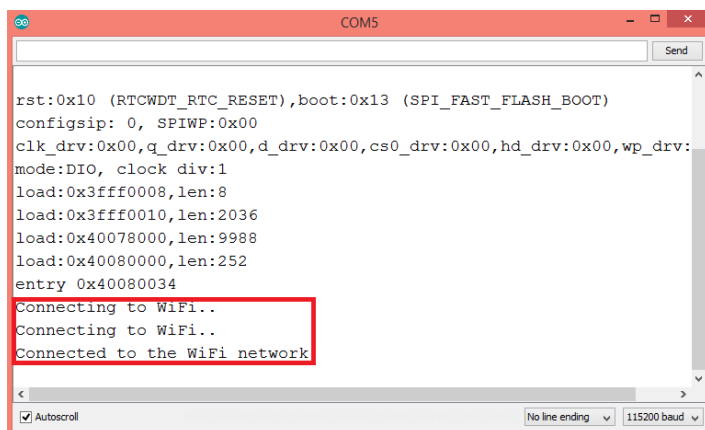

Fig -8: Serial Output Connection Status of ESP8266 Wi-Fi Module

6. WORKING AND ANALYSIS

In this prototype of collision avoidance vehicles in the line of sight will be connected to each other in the manner antecedent vehicle will be connected to the preceding vehicle only. The connection between the two vehicles will be wireless and established through the ESP8266 Wi-Fi

module. The ultrasonic sensor will calculate the distance between two vehicles and send it to the microcontroller and if the distance is less than the predetermined distance then the speed of the DC motor is controlled through MOSFET which is used as a motor driver and brake is applied to avoid the accident. The ultrasonic sensor will also detect any other obstacle in front of the vehicle and a brake is applied to avoid the collision. The output speed sensor and ultrasonic sensor i.e. speed and distance will be displayed on the LCD. If somehow this system fails and the accident happened the crash detection sensor will detect it and will send the location of the vehicle with the help of the SIM808 module to all nearby vehicles and the emergency contacts for immediate help.

This system not only prevents an accident but also helps in traffic management, efficient traffic flow thus helps in maintaining safe and efficient traffic flow in Intelligent Transport System (ITS). This system has the capability of providing priority to the emergency vehicles on road.

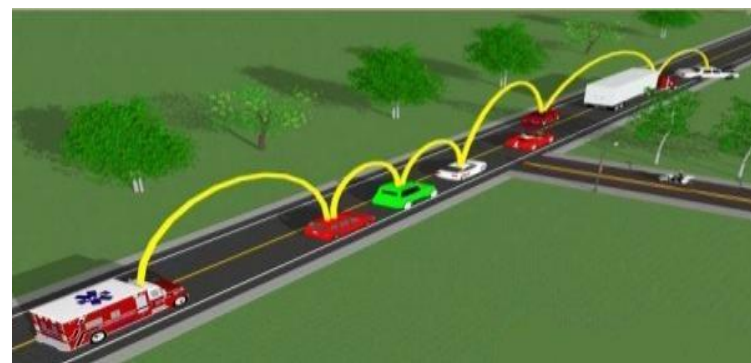

Fig -9: Connected Vehicles in Line of Sight

7. CONCLUSION

In this paper, the Collision Avoidance System is discussed by using the concept of Vehicle to Vehicle (V2V) Communication through Vehicular Ad Hoc Network (VANET) technology also the backup technique if this system fails is discussed. This system is powerful enough to prevent road accidents and the main purpose of our system is high speed processing, cost-effectiveness, reliability, accuracy. In the near future, this suggested system has the capability of providing priority to the emergency vehicles on road.

REFERENCES

- [1] A.Boukerche et al., "Vehicular Ad Hoc Networks: a new challenge for localization-based systems", Computer Communications, Science Direct, pp. 1-12,2008.
- [2] Thiruvallur, V. & Vimal, E.. (2021). Smart Traffic Management for Collision Avoidance Using V2V.

Bonfring International Journal of Industrial Engineering and Management Science. 11. 01-07. 10.9756/BIJEEMS/V11I1/21001.

- [3] Botkar, Sonali & Godse, Sachin & Mahalle, Parikshit & Shinde, Gitanjali. (2021). Communication in VANET. 10.1201/9781003157069-2.
- [4] G. S. Khekare and A. V. Sakhare, "A smart city framework for intelligent traffic system using VANET," 2013 International Mutli-Conference on Automation, Computing, Communication, Control and Compressed Sensing (iMac4s), Kottayam, India, 2013, pp. 302-305, doi: 10.1109/iMac4s.2013.6526427.
- [5] A. Demba and D. P. F. Möller, "Vehicle-to-Vehicle Communication Technology," 2018 IEEE International Conference on Electro/Information Technology (EIT), Rochester, MI, USA, 2018, pp. 0459-0464, doi: 10.1109/EIT.2018.8500189.
- [6] Image source Google.
- [7] Khadse, G., & Adhav, N. (2016). Comparative study of data transfers using Wi Fi modules. *International Journal Of Enaineering And Technical Research (IJETR)*, Volume-5(Issue-4).
- [8] Sivakumar, S., Alagumurugan, A., B.Baala Vignesh, G., & Dhanush, S. (2020). ACCIDENT ANALYSIS AND AVOIDANCE BY V2V COMMUNICATION USING LIFI TECHNOLOGY. *International Research Journal Of Modernization In Enaineering Technology And Science*, 02(03), 1-5. Retrieved 12 April 2021, from.

**Co-Author⁴**

"A zestful and empirical engineering student having good communication and programming skills."

**Co-Author⁵**

"A nice fun and friendly person who is honest and punctual, also work well in a team but also on her own as like to set herself goals which will be achieved, having good listening and communication skills."

**Co-Author⁶**

"A motivated and enthusiastic team player, reliable for team mates, with good communication and ability to work under high pressure with mutual skills."

BIOGRAPHIES

**Author¹**

"A dynamic and result oriented engineering student, proficient in communication and having wide set of technical and interpersonal skills."

**Co-Author²**

"An enthusiastic engineering student with expertise in technology and communication. Having good communication skills."

**Co-Author³**

"A hardworking individual who is good timekeeper, always willing to learn new skills and friendly, helpful, polite. Always able to work independently in busy environments and also within a team setting."