

## Development and Analysis of Angle Shear Die

G.Ravisankar<sup>1</sup>, P.Vijayakumar<sup>2</sup>, TTM.Kanann<sup>3</sup>, S.Sukumar<sup>4</sup>, P.Renukadevi<sup>5</sup>

<sup>1</sup>M.Tech student, Department of Mechanical Engineering, PRIST Deemed to be University, Thanjavur-613403, India,

<sup>2-4</sup>Associate Professor, Department of Mechanical Engineering, PRIST Deemed to be University, Thanjavur-613403, India,

<sup>5</sup>Assistant Professor, Department of Mechanical Engineering, PRIST Deemed to be University, Thanjavur-613403, India,

\*\*\*

**Abstract** – Metal Shearing is a widely used process in high volume production of sheet metal components. The main objective of this paper is to present the development of a model to predict the form of the cut side. This paper presents the enhanced design of angle shearing die and punch for efficient shearing. The Die and punch are made using Oil hardened no shrinking steel (OHNS) and surface hardened by cyanide heat treatment method. The Supporting Block are made using EN8 Carbon steel. The Hardness of the fabricated die is measured by Rockwell Harness testing method and we have analyzed the stress and deformation in the Die assembly through ANSYS software. We have attempted to avoid unwanted or irregular cutting surface of specimen and to obtain efficient shearing operation.

**Key Words:** Shearing Die, OHNS, Design, Fabrication, FEM

### 1. INTRODUCTION

In today's industrial era the most basic thing for any industry is to supply and manufacture the merchandise with shortest time interval and with greatest accuracy. Shearing die is widely used in our present day manufacture industry. Die design, an outsized division of tool engineering may be a complex, fascinating subject. It is one among the foremost exciting of all areas of the overall field of tool designing. Industrial era demands something that is simple and economical in this regard the shearing die will play a very important role. The first step of designing a shearing die is to study the piece part drawing carefully and to plan the operations to be carried out in different stations. The drawing of the stock strip is laid out because it will appear after it has skilled all stations, till a finished piece part is far away from it. It should be dimensioned and should carry all information's necessary to start with the tool design like the feed direction, the amount by which the strip advances after each stroke of the press. The metal is delivered to the plastic stage by pressing between two shearing blades in order that fracture is initiated with the movement, finally results in the separation of the slug from the parent strip. The two shearing elements of the press tool are the hardened punch and the die plate having sharp edges and a particular shearing clearance. The punch is connected to the ram of the facility press and while descending contacts the stock, exerts pressure over the stock round the cutting edges and shears it precisely. [1] Fabrication of Shearing Die and Supporting block using unconventional machining technique like EDM wire cutting and by conventional machining like Milling by using EN8 Carbon Steel material. PRO E is used to Design the Angle Shearing Die and the supporting block.[2] Surface hardening of the Die and Supporting block are made by cyanide heat treatment process.[3] Analyzed hardness of the Die and Supporting block. Rockwell hardness testing procedure is adopted as measuring method [4] Assessment of stress distribution and deformation in Die and the punch are done through ANSYS software. Finally Angle Shearing Die is developed, and analyzed. It is recommended to avoid unwanted or irregular cutting surface of specimen and for efficient shearing operation.

### II- METHODOLOGY

In this Experimental work, we design and fabricate the angle shear die which is made of EN 8 steel. The proposed die design (fig 2.1 & 2,2) such as Base with die assembly( fig 2.3) and punch with holder assembly (fig 2.4) created by PRO-E modeling software. The model is fabricated as per design drawings of die and punch assembly.

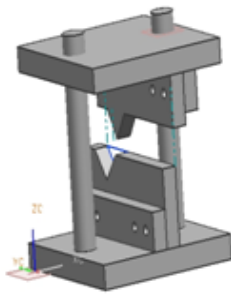

Fig: 2.1 Existing model

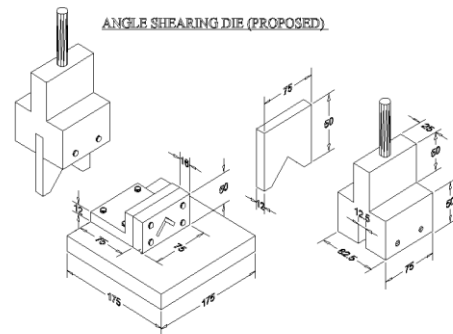

Fig: 2.2 proposed model

2.3 PRO E Design of Proposed Angle shearing die

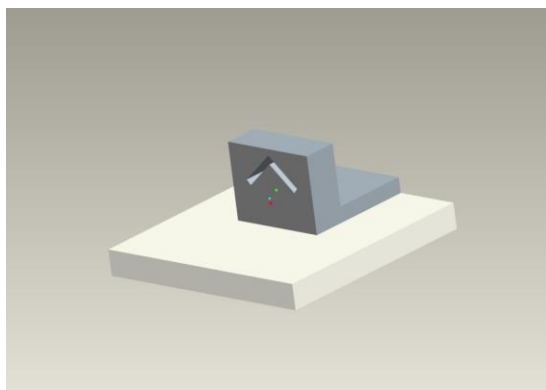

Fig: 2.3 Base with Die Assembly

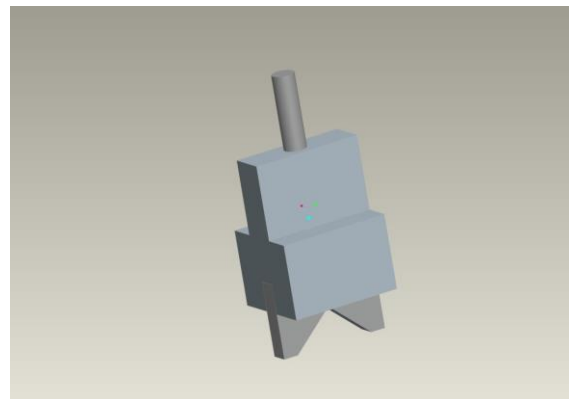

Fig: 2.4 Punch with holder Assembly

2.4 Design calculation of angle shearing die

The angle shear die design parameters and corresponding calculations are given and referred by PSG data book.

2.4.1 Material calculation

$$A_1 = l \times b = 23 \times 3 = 69 \text{ mm}^2$$

$$A_2 = l \times b = 26 \times 3 = 78 \text{ mm}^2$$

$$A = A_1 + A_2 = 69 + 78 = 147 \text{ mm}^2$$

2.4.2 Shear stress:

$$\text{Shear stress} = 0.5 \times \sigma_y / n$$

Where,

n = factor of safety = 0.3

$\sigma_y$  = tensile stress for m.s plate

$$= 0.5 \times 380 / 0.3$$

$$= 633.33 \text{ N/mm}^2$$

Shear stress = load/area

Shear stress x area = load

$$633.33 \times 147 = F$$

$$F = 93.09 \text{ KN}$$

2.4.3 Die clearance:

$$C = 0.0032t\sqrt{fs}$$

Where,

$$t = \text{thickness of material} = 3\text{mm}$$

$$= 0.0032 \times 3 \times \sqrt{380}$$

$F_s$  = Shear strength

$$C = 0.18 \text{ mm}$$

### 3. RESULT AND DISCUSSION

In this work involves fabrication of the shearing die and punch with holder by unconventional machining EDM wire cutting and by conventional machining Milling, the fabricated shearing die with supporting block and punch with holder is hardened by cyanide heat treatment process. EN8 Carbon steel is used as raw material for supporting block and Oil hardened no shrinking steel OHNS is used as raw material for shearing die (fig 3.1 & 3.2). After fabrication of angle shearing die and supporting block, hardness values are measured.(Table 3.1 & 3.2)

#### 3.1 Fabrication of angle shearing die

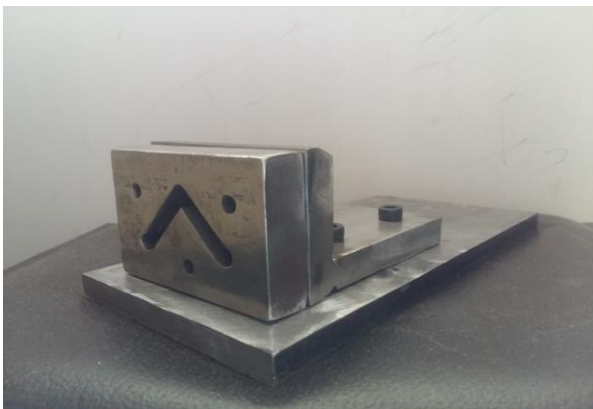

**Fig: 3.1 Base with Die Assembly**



**Fig: 3.2 Punch with holder Assembly**

Hardness of shearing Die

**Load = 150kgf**

*Table: 3.1 Hardness of Shearing Die*

Trail	HR <sub>c</sub>
1	57
2	53
3	55
4	53
5	54
Average	54

Hardness of supporting block

**Load = 150kgf**

*Table: 3.2 Hardness of Supporting Block*

Trail	HR <sub>c</sub>
1	52
2	52
3	51
4	50
5	51
Average	51

### 3.2 FEM of angle shearing die

The deformation and stress are analyzed through finite element analysis. Investigation is made to present the development of a model to predict the shape of the cut side. The Simulation study has been done to avoid the expensive and difficult experiments before actual production operations. The Simulation study is used to determine stress distribution in the Die with supporting Block and in punch. The study has been conducted on ANSYS software. The experimental work is carried out on angles having their thicknesses of 3 mm. The various parameters of die are shear elastic strain (Fig3.3), total deformation (3.4), directional deformation (3.5), Von misses stress (3.6), Shear stress (3.7) and elastic strain (3.8) are analyzed by finite element methods.

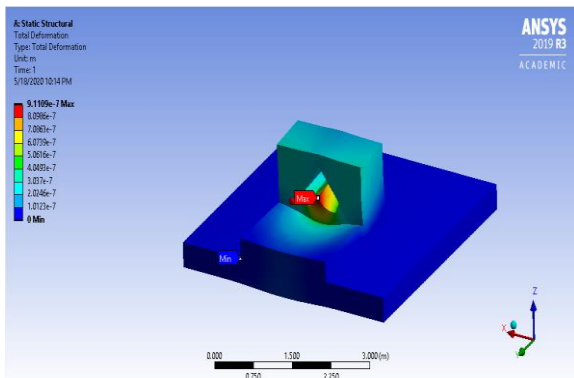

Fig: 3.3 Shear Elastic Strain

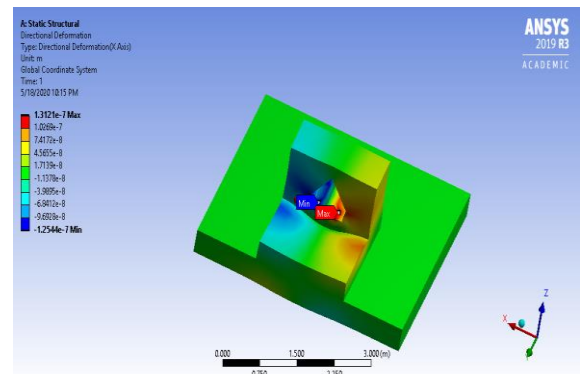

Fig: 3.4 Total Deformation

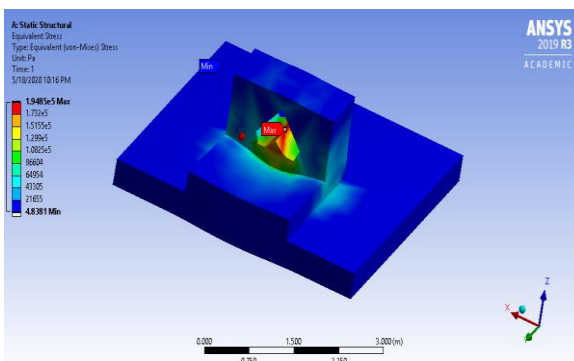

Fig: 3.5 Directional Deformation

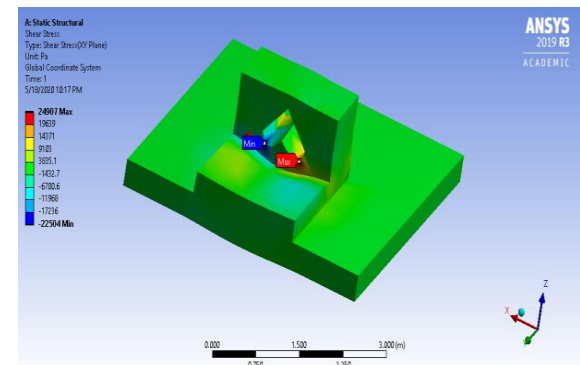

Fig: 3.6 Equivalent Von Misses Stress

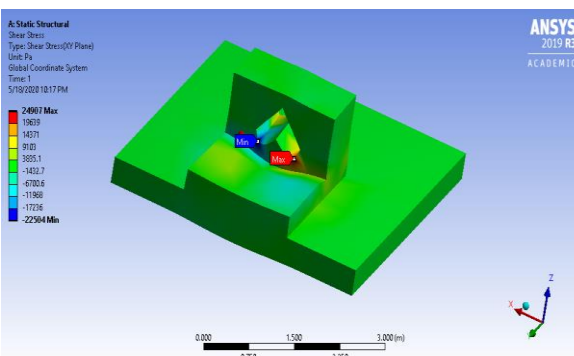

Fig: 3.7 Shear Stress

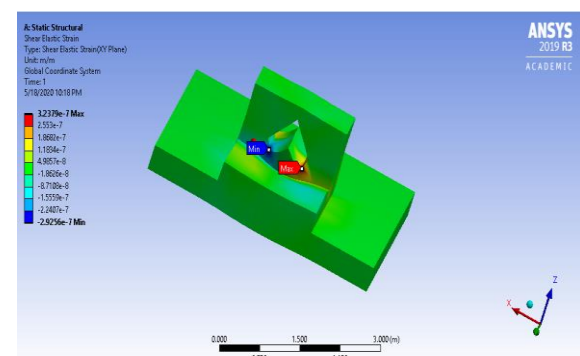

Fig: 3.8 Equivalent Elastic Strain

Table: 3.3 Result Summary

RESULTS	MINIMUM	MAXIMUM	UNITS	TIME(s)
Shear Elastic Strain	-2.9256e-007	3.2379e-007	m/m	1.
Shear Stress	-22504	24907	Pa	1.
Total Deformation	0	9.1109e-007	m	1.
Directional Deformation	-1.2544e-007	1.3121e-007	m	1.
Equivalent Elastic Strain	2.419e-011	9.8483e-007	m/m	1.
Equivalent Stress	4.8381	1.9485e+005	Pa	1.

The various parameters of shear strain, shear stress, deformation, equivalent elastic strain and stress of die block and holder is presented in the table 3.3. The analysis showed that the prediction of failure occur in between the die and punch. Especially the inner surface of the die where the specimen is placed was attained more shear stress in XY direction. Based on the Von Miss Stress distribution and the values identified through the finite element analysis, optimum stress was developed in the die inner surface area. Stresses are all directional and the consolidated stress is normal.

#### 4. CONCLUSIONS

In this work we concluded that the analysis showed that the prediction of failure occur in between the die and punch. Especially the inner surface of the die where the specimen is placed was attained more shear stress in XY direction. Based on the Von Miss stress distribution and the values identified through the finite element analysis, optimum stress was developed in the die inner surface area. The heavy impact of the punch created the cutting operation on the specimen to avoid unwanted or irregular cutting surface of specimen. We detailed with design and fabrication of shearing die with suitable drawings. Therefore, the result obtained from the work is to reduce the time taken and efficient shearing operation.

#### REFERENCES

- [1] Ivo Pahole, Karl Gotlih, Dejan Studencnik, Joze Balic, Mirko Ficko "Influence of the Milling Strategy on the Durability of Forging Tools". Journal of Mechanical Engineering 57(2011)12, 898-903.
- [2] Arda Ozgen. "Cutting strategies for forging die manufacturing on cnc milling machines".
- [3] B. Kecelj, K. Kuzman, J. Kopac - Specialty of HSC in manufacturing of forging dies. Journal of Materials Processing Technology 157-158 (2004)536-542
- [4] R.Rajendra, G.Chandramohan reddy, A.M.K.Prasad, K.L.Udaykiran "Study of Surface integrity Characteristics on Al and Die Steel Components using Copper tool in Sink EDM Process". International Journal of Current Engineering and Technology, 2014
- [5] J R Paquin, "Die Design Fundamentals," Industrial Press Inc., 200 Madison Avenue, New York, N.Y.10016, 1962. Anthony Davidson, "Handbook of Precision Engineering, Vol.10. N.V Philips, Gloeilampenfabrieken,
- [6]. Tool design by Donaldson, Lecain, Goold published by Tata McGraw Hill company.
- [7]. Machine tools by Elanchezhian, M.Vijayan published by Anurada agencies.
- [8]. Machine tools and tool design by P.C. Charma published by S.Chand and company.
- [9]. Design of jigs, fixtures and press tools by C.Elanchezhian, T.Sunder Selwyn, B.vijaya Ramnath Published by Eswar press.
- [10]. Design of jigs, fixtures and press tools by Venkataraman published by Tata McGraw hill.