

DESIGN AND FABRICATION OF LEAF VACUUM MULCHER MACHINE

¹Mayur Shelke | ²Sumit Badode | ³Vishesh Wasnik | ⁴Yash Badole | ⁵Tushar Patil | ⁶Ritesh Shende

¹Assistant Professor, Department Of Mechanical Engineering, KDK College of Engineering, Rashtrasant Tukdoji Maharaj Nagpur University, Nagpur

^{2,3,4,5,6} Students, Department Of Mechanical Engineering, KDK College of Engineering, Rashtrasant Tukdoji Maharaj Nagpur University, Nagpur

Abstract: In many public places and colonies, leaves fell from the trees usually these leaves are gathered by sweeper and burn them in a corner which lead in air pollution. Instead of burning it can be used as compost fertilizer by applying some methods for recycling this natural debris that one of the methods is using leaves as mulch. So, for making use of leaves to its fullest we are designing a leaf vacuum which will be discussed in this paper.

Key Words: Vacuum, Crusher, Reuse,

1. INTRODUCTION

In our day to day life, we see various types of wastes along with shed leaves sometimes beside roads or even walk ways in locality. This causes various organisms to take birth resulting in different diseases to the living being nearby it. We have volunteers of Municipal Corporation to clean those wastes from locality and drop them to dump yard. But usually sweepers gather all the leaves from the ground and arrange it at road side and burn it, as it's not efficient for them to move those waste materials to dump yard, each and every time. So in order to avoid burning of this waste material causing harmful gases and air pollution, we have designed leaf vacuum system which is in order to save the man power required for raking and also to separate and recycle the natural debris from it as well as the other unwanted materials. This system will help to collect large quantity waste in smaller place and later on to carry the same material for processing of it.

1.1 PROBLEM STATEMENT

Cleaning the leaves is a tiring as well as time consuming task. In spite of cleaning leaves manually, it's quite difficult carry those leaves in one take for elderly and the disabled. As a result burning these leaves is the only option left for such peoples, which causes air pollution.

1.2 OBJECTIVE

The main objective of our project is to design and manufacture a vacuum mulch system that will help in cleaning work so that the efficiency cleaning operation is increase.

We know in collecting the leaves it take too much effort for our labor first they have to gather then put in one sack or a box, after that they put the leaves in dumping yard it became very time consuming work so to resolve this issue and save time our project will help the labor. When labors or workers dump or simply fire them without thinking about their repercussions the firing the leaves create air pollution hence to reduce the effect of the shaded leaves on surface and pollution caused by it we are going to design a leaf vacuum mulcher machine. We can have one more benefits from it because of the shredded leave we used them as a organic fertilizer without wasting a single penny on it.

2. LITERATURE REVIEW

1984 John et. al. DESIGN OF LEAF AND TRASH ASSORTMENT EQUIPMENT the target of the invention is to produce a equipment for cleaning up leaves & different trash from lawns, flower beds.

1992 Michael et. al. CONVERTIABLE BLOWER VACUUM a device which is used as a blower or to control as a vacuum. Blowers which might convert to vacuums give an extra degree of skillfulness to the current product.

1980 Charles et. al. TRANSPORTABLE BLOWER-VACUUM UNIT improvement of vacuum unit. A mulching blade rotates with the blade to cut any solid material passing through the hose.

1995 David et. al. CONVERTIABLE LEAF BLOWER AND VACUUM EQUIPEMENT optimizing device to be a equipment.

1986 Robert et. al. REPRESENTS CONVERYTIBLE VACUUM BLOWER ARRANGEMENT incorporates a housing having associate degree air body of water associate decreed an air outlet in disclosed.

3. RESEARCH METHODOLOGY

- Planning of the project
- Selection of the material
- Designing the parts and assembly
- Working
- Usage

4. Selection of Components

Components			
1.	Frame	5.	Bag
2.	Motor	6.	Pipe
3.	Air blower	7.	Cover Body
4.	Suction chamber	8.	Hand grips

5. ASSEMBLY

The arrangement of the part includes the motor, vacuum and the structure of the collector capacity. The collector is arranged in such a way that they are used for collecting the easy disposal of the leaf. CAD diagrams using Fusion360.

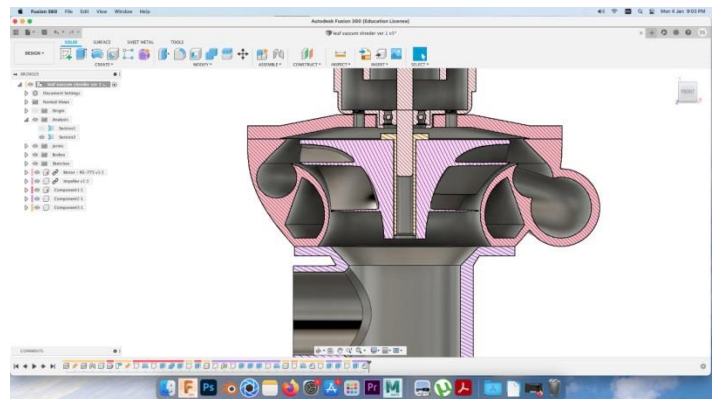
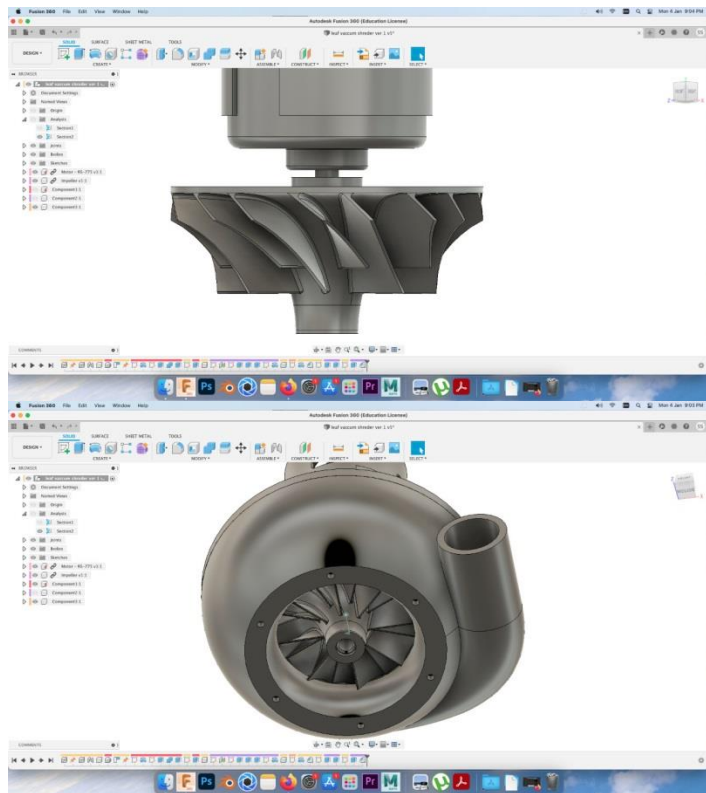

Part for which a 3d printer is used is



6. WORKING

The leaf is collected by the vacuum by the hose connected to it. The sucked leaf is fed into the blade which is driven by the motor. Then the leaves are chopped into several small pieces by the blade. The size of the leaf is reduced to small, then the collected leaves can be used as the manure for the garden or parks.

Before Processing



After Processing



7. APPLICATION

- The issues of the disposal of leaves can be solved.
- Organic manure is obtained instead of burning them openly and release of harmful substances into the atmosphere.
- Collecting and carrying gets easier.
- Public places are easily cleaned and this machine is easy to use.

8. CONCLUSION

The main aim of this project is to make a clean environment with less human effort. The leaves that are collected is chopped well by the blade attached to the motor. The chopped leaves can be used as manure or mulch for the garden purpose. This project is collecting the leaves in the garden, roadways, pathways etc. The human power is reduced and time consumption is reduced for collecting the leaves. It is cost effective and easy operating mechanism compare to other leaf collecting instruments and machines. It is eco-friendly and energy efficient and does not cause any pollution the society.

REFERENCES

- [1] <https://www.bestgardenoutdoor.com/walk-behind-leaf-vacuum-mulcher/>
- [2] <https://www.fresh-group.com/leaf-clearing-equipment.html>
- [3] <https://www.leafblowersdirect.com/lawn/walk-behind-lawn-vacuums.html>
- [4] Anonymous, 2008. Lawn and tractor collection system catalogue, John Deere Company, USA, <http://www.johndeere.com>.