

Quick Lifting Jack with Spur Gear Arrangement

KAMALESRE P S¹, MUTHUSARAVANAN M², NANDHAKUMAR M³, PRAGATHEESWARAN G⁴,
Dr.M.ELANGO VAN⁵

^{1,2,3,4}UG Scholar, Department of mechanical Engineering, SNS College of Technology, Coimbatore, India.

⁵Dr.M.ELANGO VAN⁵ Professor, Department of mechanical Engineering, SNS College of Technology, Coimbatore, India.

Abstract: After studying the challenges of lifting any sort of light vehicle, we came up with our project, "FABRICATION OF QUICK LIFTING JACK WITH SPUR GEAR ARRANGMENT." As a result, the project has shifted its attention to this issue, and a suitable device has been created. So that the vehicle can be pushed off the ground without having to use any impact force and the vehicles are easily transported. There is no manual supervision, and it is simple to repair and replace parts.. The manufacturing process has been considered in almost every case because of its flexibility and cost-effectiveness.

1. Introduction

The Fast LIFTING JACK for automobile garages was designed to meet the needs of small and medium-sized garages, which are normally man-powered and have a small number of professional employees. The majority of garages use a screw jack to lift vehicles. A large amount of manpower, as well as skilled labour, will be needed. To put an end to all of these drawbacks. This hydraulic jack with motor has been designed to lift a vehicle smoothly and without creating any impact force. The operation of the motorised hydraulic jack is made simple enough for even unskilled labour to handle by demonstrating its purpose only once. Via a cam mechanism, the hydraulic jack is attached to the DC motor. The cam shaft moves up and down due to the rotary motion of the DC motor, which is driven by a spur gear arrangement. This is a straightforward automation project.

1.1 Machine components

The components that are used in the project QUICK LIFTING JACK WITH GEAR ARRANGEMENT are as follows

- Frame
- Bearing
- Battery
- DC Motor
- Spur gear
- Hydraulic jack

1.2 Description of Equipment

DC MOTOR: A system that transforms electrical energy into mechanical energy is known as an electric motor. A current-carrying conductor encounters a magnetic force that meets Fleming's left hand law when it is put in a magnetic field. Torque is generated when a motor is turned on. This torque can cause physical rotation.

Hydraulic jack : Hydraulic jack are distinguished by their use of an incompressible liquid, such as hydraulic fluid or jack oil, as the means by which force multiplication is achieved. Hydraulic jack are distinguished by their use of an incompressible liquid, such as hydraulic fluid or jack oil, as the means by which force multiplication is achieved.

Spur gear : One of the most common types of precision cylindrical gears is spur gears. Straight, parallel teeth are placed around the circumference of a cylinder body with a central bore that fits over a shaft in these gears. The gear is machined with a hub in many configurations, thickening the gear body around the bore without adjusting the gear face.

Bearing : A bearing is a machine component that reduces friction between moving parts by restricting relative motion to only the desired motion. The bearing may be designed to allow free linear movement of the moving part or free rotation around a fixed axis; or it may be designed to prevent motion by regulating the vectors of normal forces acting on the moving parts.

2. Literature Survey

PRATHER, THOMAS J. (2009) There was an introduction to the vehicle lift system in this. The piston was mechanically connected to a drive assembly. The drive assembly was rotated in the first direction to lift the piston's upper end in relation to the housing. To lower the piston's upper end in relation to the housing, the drive assembly was moved in the opposite direction. The drive assembly was connected to a removable power supply port that provided the drive assembly with electrical power.

FARHAD RAZZAGHI (2007) demonstrates an electrically driven jack that can be used to lift and lower a car from the ground. The mechanism can be used in conjunction with a standard portable car jack, and it consists of a power drill, a rod, and a variety of jack adapters.

PATIL MANOJ (2014) Screw jack is to be designed in this general article to overcome human effort. For pregnant women and the elderly, operating is a difficult task. It is not a pleasurable experience to change a tyre. Women, in particular, are unable to operate with greater force. As a result, an electric car jack is introduced. tarachand lokhande (2012) The purpose of this paper was to improve the effectiveness of a square threaded mechanical screw jack by varying the helix angle.

R.S. AND J.K. GUPTA With the advancement of technology, the amount of effort required to produce any type of work has been steadily declining. By implementing better designs, the effort needed to achieve the desired output can be reduced effectively and economically. Power screws are used to convert rotary motion into translatory motion. A screw jack is an example of a power screw that raises or lowers a heavy load with a small force applied in a horizontal plane. Its working principle is analogous to that of an inclined plane. The ratio of the load applied to the effort applied is the mechanical advantage of a screw jack. A lead screw is used to operate the screw jack. The height of the jack can be adjusted by turning a lead screw, which can be done manually or with the help of an electric motor. An electric motor will be integrated with the screw jack in this project, and the electricity required for operation will be drawn from the vehicle's battery, increasing the mechanical advantage.

3. Block Diagram

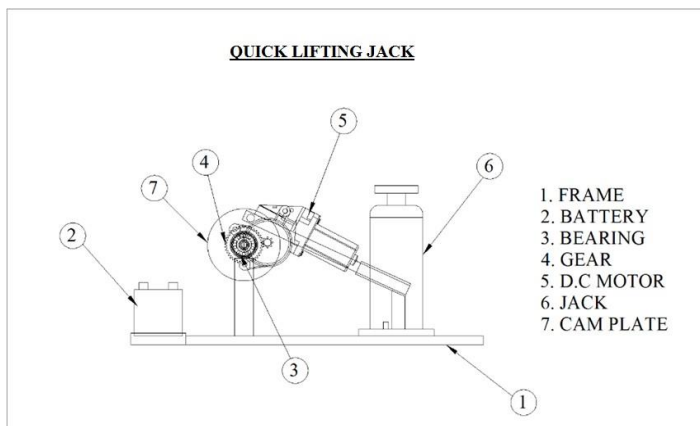

Fig 1.Quick lifting jack

4. Proposed System

Figure 1 is a block diagram of the Fast LIFTING JACK WITH GEAR ARRANGEMENT. The d.c motor is powered by a lead-acid battery. A spur gear arrangement links the d.c motor shaft to the cam wheel. When the D.C motor is driven, it will spin at the same speed as the D.C motor, which allows the cam wheel to spin at the same speed as the D.C motor. The cam mechanism raises and lowers the cam shaft. On the other end, the hydraulic pump handle is connected to the cam shaft. In addition to the movement of

the cam shaft, the hydraulic handle swings up and down. As a result, pressurised oil is guided to the hydraulic jack, which lifts the vehicle off the ground by raising the piston.

5. Conclusions

This project has given us an excellent opportunity to bring our limited experience to good use. While working on this project, we gained a lot of practical experience planning, ordering, assembling, and machining. We are pleased that we were able to complete the work in such a short period of time.

The "Quick LIFTING JACK WITH GEAR ARRANGEMENT" functions perfectly. We understand how difficult it is to keep tolerances and, more importantly, accuracy in order.

We have worked to the best of our abilities, making the most of the opportunities at our disposal. Last but not least, some reflections on our dream. As a result, the "Fast LIFTING JACK WITH GEAR ARRANGEMENT" was born. By using additional methods, they can be revised and enhanced in accordance with the applications.

6. Advantages

- The oil in this system is used to keep the system's moving parts cold. As a result, no additional cooling equipment is needed for this project.
- The light vehicles are easily transportable when fully loaded.
- Checking and cleaning are simple since the key components are screwed together.
- It is easy to manage.
- There is no manual supervision, and it is simple to repair and replace parts.

7. Application

- It's ideal for four-wheeler applications.

8. References

- 1) V. P. Bondaletov, "Pawl Motion in Free-Running Ratchet Gear at High Ratchet Speeds", ISSN 1068-798X, Russian Engineering Research, 2008, Vol. 28, No. 9, pp. 845-848.
- 2) J. A. Kennedy, L. L. Howell, "The Ratchet and Pawl Ring (RaPR) Mechanism", 12th IFToMM World Congress, Besançon (France), June18-21, 2007.
- 3) V. P. Bondaletov, V. I. Medvedev, and A. V. Petrov, "Extending the Life of Free_Wheel Ratchet Mechanisms by Backup of the Working Components", ISSN 1068_798X, Russian Engineering Research, 2010, Vol. 30, No. 12, pp. 1208- 1219

4) I.S. Rout et al., Design and fabrication of motorized automated object lifting jack, IOSR Journal of Engineering. 04(05) (2014) 6-12.

5) K.R. Mounika, C.H. Priyanka, Design and fabrication of motorized screw jack for four wheeler, A Project Report, Department of Mechanical Engineering, Gokaraju Rangaraju Institute of Engineering and Technology, 2011.

6) C.A. Okoronkwo et al., Design of a hand water pump using a quick-return crank mechanism, African Journal of Science, Technology, Innovation and Development. 8(3) (2016) 292-298.

7) S. Chaudhary et al., Development of motorized car jack, Journal of Applied Mechanical Engineering. 5 (2016) 216.

8) M.N. Kumar et al., Design and fabrication of screw jack using worm gear, International Conference on Systems, Science, Control, Communication, Engineering and Technology, 2016, pp. 794-798.

9) R.K. Rajput, A textbook of engineering thermodynamics, Firewall Media, 2010. International Journal of Engineering and Technologies Vol. 13 49 10) M.A. Parker, F. Pickup, Engineering drawing with worked examples, Third Edition, Vol. 1, Hutchinson, New Delhi, 1976, pp. 690-699.

11) Manufacturing technology (Machine Processes & Types), -G.K.Vijayaraghavan.

12) Engineering economics & cost analysis (Cost of Material), -S.Senthil, L.Madan, N.Rabindro Singh.

13) Design data book - PSG College of technology

14) Strength of materials - R.S Kurmi

15) <https://www.semanticscholar.org>

16) <https://engineeringhelponline.xyz>

17) <https://www.ijedr.org>