

## Design and Fabrication on Cultivator and Sprayer Machine

Niraj B kendre<sup>1</sup>, Abhishek M Lodh<sup>2</sup>, Vipin Tekade<sup>3</sup>, Prashant Shende<sup>4</sup>

<sup>1,2,3</sup>B.E. Student, Dept. of Mechanical Engg., Yashwantrao Chavan College of Engineering, Nagpur.

<sup>4</sup> Professor of Mechanical Engg. Dept., Yashwantrao Chavan College of Engineering, Nagpur.

\*\*\*

**Abstract:** In the Indian economy, agriculture holds a dominant position. Due to changes in climate and inflation of the insects, pests, etc. it is vital to protect the crop by getting rotten and damaged by insects using pesticides and fertilizers. The main objective of this project is to help the farmers by reducing their efforts and enhance operation speed. Pesticide sprayer pump mounted on a frame with a wheel which is operated mechanically without using any external source of energy. After completing spraying the pump is removed and replaced by fertilizer spreader. It is a multipurpose model that is efficient in operation. The advancement of this concept prevents the defects of the pump being used conventionally. The farmer has to carry the pesticide in the pump and then spraying which is another rigorous task to be completed. One hand is continuously busy operating the handle and the farmers don't take enough precautions which result in fatal diseases because of direct contact with the chemicals.

The farmer acute labor shortage, decreasing income per acre of cultivation, and economic frustration are some of the key factors hurting a farmer's confidence in continuing farming. Hence mechanical Cultivator is necessary to reduce the labor force. Environmental degradation and pollution caused by chemical is reduced by the use of Mechanical Cultivator. We have developed mechanical power Cultivator with Sprayer.

**Keywords:** Enhance operation speed, reducing their efforts, multipurpose model, conventionally, Rigorous task, Labour force, degradation and pollution.

**Introduction:** In India, almost 75% of the population are dependent on agricultural for economic growth. So the agricultural system in our country should be changed to reduce the manual efforts of farmers required while farming. It includes the various operations is to be performed in the agricultural field like sowing, ploughing, cutting, fertilizer spraying in a manual manner by the farmers. One of the basic and significant operations is seed sowing which is a lot time consuming process. So the traditional equipment used for sowing is very difficult and inconvenient to handle. So there is a

need to re-develop the machine which will minimize the manual efforts of farmers such as Broadcasting and Dribbling. To overcome these difficulties, in this paper, efforts had been taken to develop a Cultivator and Sprayer machine. This technology in the farming system minimizes the efforts taken by the farmers, saving their time, labor cost and their energy as well.

### Literature review:

- 1) **Performance Evaluation of Power Tiller in Bauchi State Nigeria Authors: F. A. Adamu, B. G. Jahun, B. Babangida [2014]** In this paper authors draws our attention towards the performance factor of a power tiller. Among those demand for light weight power tiller was sought out most. Fuel efficiency and field capacity of such parameters are also discussed. We took those points in consideration while designing a sustainable Agricultural machine.
- 2) **Employment Characteristics of Tine Cultivators at Deeper Soil Loosening Authors; P. Sarec, o Sarec [2015]** Lowest values of soil penetration resistance below the cultivated profile were determined with the cultivators equipped with chisel shaped shares, i.e. in the case of Farmed and Kockerling. These results have taken for our research basis.
- 3) **Kamlesh Kishor Rangari, Swapnil B. Bandane, Pravin Jaybhaye, Dr. S.K. Choudhary, Prof. R.D. (2015)** "Design and fabrication of organic fertilizer and pesticides sprayers". International Journal for Scientific Research & Development| Vol. 3, Issue 01, 2015 | ISSN (online): 2321- 0613.
- 4) **P. V. Sawalakhe and Amit , Sontakke, (global journal of solar seeding machine), [Cited on research paper]- 2016** they investigated that there is a rapid development in all sector including the agricultural sector as well. So in order to meet the future food requirements, the farmers need to change their techniques to overcome the traditional method of farming. This

Paper describes the various sowing methods implemented in agriculture for seed placements.

**Problem Statement:**

There are many developments in the existing cultivating machineries but it is too costly. It is not affordable for each and every farmers in India as It has a complex design and inconvenient to handle. Basically, it is not compact in size and their weight is a major factor for handling purpose and hence, it requires a much effort to accomplish its transportation cost from one place to another place.

Reason for selecting the problem:

1. Lack of mechanization in farming
2. Required excess efforts for different process
3. Required more man power
4. Excess time consumption for performing individual process

**Objectives:**

- To study the farming process.
- To Design and development of Multipurpose Cultivator.
- To perform the field testing and Design Finalization

**Concept Diagram:**

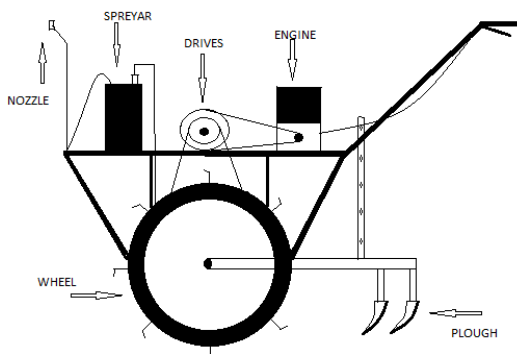

**MAJOR COMPONENT IN THE PRAPOSED MACHINE:**

- ENGINE
- CHAIN DRIVE
- SPROCKET
- PLOUGH
- WHEELS

- SPRAYER

**Component Details:**

**Engine:** An engine is some machine that converts energy from a fuel to some mechanical energy, creating motion in the process.

**Wheels:** Ground wheel is the primary drive given by the driver to generate the power in the device. The ground wheel consists of a circular disc having a number of teeth provided on their periphery i.e., at their outer circumference and it provides a fine grip with the land.

**Power Transmission System:** It consists of a Belt drive which is connected in between the shaft through Engine then it's transmitting to chain drive to wheels.

**Sprayer:** A sprayer is a device used to spray a liquid, where sprayers are commonly used for projection of water, weed killers, crop performance materials, and pest maintenance chemicals.

**Plough:** Used to turn and break up soil, to bury crop residues, and to help control weeds.

**DESIGN AND ANALYSIS:**

\*CALCULATIONS FOR TOTAL POWER REQUIRED TO MACHINE:

POWER REQUIRED FOR SELECTION OF ENGINE:

$$\text{Power} = \text{Pressure} \times \text{Area} \times \text{Velocity}$$

$$\text{Power} = \text{Soil resistance} \times \text{Area} \times \text{Velocity}$$

POWER REQUIRED TO WEEDING BLADE:  $\text{Power} = \text{Soil resistance} \times \text{Area} \times \text{Velocity}$

$$\begin{aligned} \text{Soil Resistance (S.R)} &= 1.05 \text{ Kg/cm}^2 \\ &= 1.05 \times 9.81 \\ &= 0.0001 \text{ N/m}^2 \\ &= 103005 \text{ N/m}^2 \end{aligned}$$

$$\text{Area (A)} = \text{Depth of Cut (mm)} \times \text{Width of Cut (mm)}$$

$$= 0.050 \times 0.450$$

$$= 0.0225 \text{ m}^2$$

$$\text{Linear Velocity (V)} = \frac{\pi DN \times \mu}{60}$$

Where,

$$\mu = \text{Coefficient of Friction} = 0.1 \text{ N} = 160 \text{ R.P.M.}$$

$$\text{Linear Velocity} = \frac{\pi \times 375 \times 160 \times 0.1}{60}$$

$$= 3.146 \text{ m/s}$$

So,

$$\begin{aligned} \text{Power} &= \text{Soil resistance} \times \text{Area} \times \text{Velocity} \\ \text{Power} &= 103005 \times 0.0225 \times 3.146 \times 0.25 = 1822.80\text{W} \\ &= 1822.80\text{hp} = 2.44\text{hp} \\ &746 \end{aligned}$$

$$\begin{aligned} \text{Total Power} &= P = \frac{\text{Power}}{\eta} \\ &= \frac{2.44}{0.80} \\ &= 3.054\text{hp} \end{aligned}$$

Where,  $\eta$  = Transmission efficiency.

**\*POWER REQUIRED FOR WHEELS:**

$$\begin{aligned} \text{Power} &= P_W = \frac{R \times V \times 1000}{1000 \times 60 \times 60} \quad \text{hp} \\ &= \frac{R \times V}{1000} \quad \text{in Kw} \end{aligned}$$

Where,  
 $R = (R_a + R_r)$  When Vehicle moves along level road  
 $V$  = Speed of Vehicle in Km/hr.

$$\text{Power required to drive the wheel} = P_w \quad \text{inKW}$$

$$\begin{aligned} &= \frac{3600 \times \eta \times \pi \times D \times N}{60 \times 1000} \\ \text{Where,} \\ \eta &= \text{Transmission efficiency} \\ R_a &= \text{Air Resistance (N)} \\ R_r &= \text{Rolling Resistance (N)} \\ \text{Air Resistance-} \\ R_a &= K_a \times A \times V^2 \\ \text{Where,} \\ K_a &= \text{Coefficient of Air Resistance (N/m}^2\text{)} \\ &= 0.023 \text{ [Best Streamline Shape]} \\ A &= \text{Projected Frontal Area (m}^2\text{)} \\ &= 0.75 \times 0.15\text{m}^2 \\ &= 0.1125 \text{ m}^2 \\ V &= \text{Speed of Vehicle (Km/hr)} = \frac{\pi D N}{60 \times 1000} \times 60 \text{ m/min} \\ &= \frac{\pi \times 0.0225 \times 160 \times 60}{60 \times 1000} \text{ m/min} \\ &= 0.8738 \text{ Km/ hr} \end{aligned}$$

Therefore,  
 Air Resistance =  $K_a \times A \times V^2$   
 $= 0.031 \times 0.1125 \times (0.8738)^2$   
 $= 0.002662\text{N}$  [It is negligible]  
 Rolling Resistance-  $R_r = K \times W$   
 Where,

$$\begin{aligned} W &= \text{Total Weight of the Vehicle (in N)} \\ &= 1500 \text{ N} \\ K &= \text{"Constant of rolling resistance"} \\ &= 0.0059 \text{ [For Good Road]} \\ &= 0.18 \text{ [For Loose sand Road]} \\ &= 0.015 \text{ [For Representative Value]} \\ R_r &= K \times W \\ &= 0.18 \times 1500 \\ &= 270 \text{ N} \\ \text{So,} \\ \text{Rolling resistance} &= 270 \text{ N} \\ \text{Therefore,} \\ R &= R_a + R_r \\ &= 270 + 0.002662 \\ &= 270.00266 \text{ N} \\ \text{Power required-} P &= \frac{R \times V}{3600 \times \eta} \quad \text{in Kw} \\ &= \frac{270 \times 3.146}{0.8} \\ &= 1061.423 \text{ KW} \\ &= 1061.423 \\ &746 \quad \text{hp} \\ &= 1.423\text{hp} \end{aligned}$$

**POWER CALCULATION:**

- 1) For Blade (Tool) = 3.05 hp
  - 2) For Wheels = 1.423hp
- TOTAL POWER REQUIRED FOR MACHINE:**  
 $P_{\text{Total}} = P_{\text{Plough}} + P_{\text{Wheels}}$   
 $= 3.05 + 1.423$   
 $= 4.473\text{hp}$   
 So, maximum power required considering some Accessories power and losses,  
 $P_{\text{total}} \cong 4.473\text{hp}$   
**SELECTION OF I.C ENGINE:**  
 Engine type: - 2 Stroke  
 Displacement:- 74.08 cc  
 Maximum Power:- 4.8 PS @6000 Rpm  
 Maximum torque:- 5.4 NM @ 4500 Rpm  
 Fuel Type:- Petrol  
 No Of Cylinder:- 1

\*Power :- 4.5 hp  
 Required Power:-  $0.3319 = 4.5 \times 0.746 = 3.357 \text{ kw}$   
 According to Max Shear Stress =  $S_{sy} = 0.5 \text{ Syt}$   
 $= 0.5 \times 320$   
 $= 160 \text{ mpa}$   
 Assume Factor Of safety= 4  
 Permissible Value Of Max Shear Stress =  $S_{sy}/f_s$   
 $= 160/4 = 40$

Power =  $2 \times 3.57 \times N \times T / 60$

T= 100.17 N.m

We Know That

Torque transmitted By the Solid Shaft and Find

Diameter = 24 mm

Say Standard Shaft Diameter Size = 24 mm Power :- 4.5 hp

Required Power:-  $0.3319 = 4.5 \times 0.746 = 3.357$  kw

According to Max Shear Stress =  $S_{sy} = 0.5 S_{yt}$

=  $0.5 \times 320$

= 160 mpa

Assume Factor Of safety= 4

Permissible Value Of Max Shear Stress =  $S_{sy} / fs$

=  $160 / 4 = 40$

Power =  $2 \times 3.57 \times N \times T / 60$

T= 100.17 N.m

We Know That

Torque transmitted By the Solid Shaft and Find

Diameter = 24 mm

Say Standard Shaft Diameter Size = 24 mm

#### CAD Design:

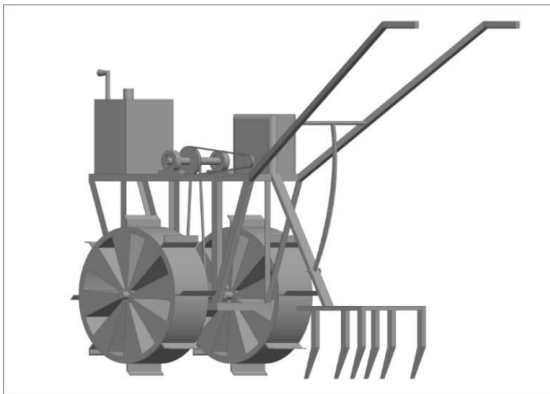

#### Conclusion:

We can infer that our planned mechanical machine is beneficial over the current machines in the accompanying ways: It is of minimal effort similarly and accounts less than 50% of the current expenses.

- This equipment consist of a low maintenance cost which does not consist of a fine texture which can be easily broken or damaged
- More no. of nozzle which cover maximum area of spray in minimum time at maximum rate. Proper adjustment facility in the model with respect to crop helps to avoid excessive use of pesticides
- Which result into less pollution? Imported hollow cone nozzle should be used in the field for the better performance. Muscular problem is removed and there is no need to operate lever...

- Proper expertise not required for working this machine and simple to exchange.

#### Reference:

- Nitin Kumar Mishra, Shashwat Khare, Sumit Singh, and Mithun Dabur, Multi-Purpose Agriculture Machine International Journal of Advances in Science Engineering and Technology, ISSN: 2321- 9009, Vol-5, Iss-1, Spl. Issue-2 pp 40-43, and Feb.2017
- Vishakha Bodke, Mahesh Gaikwad, Pratibha Patil, Karan Pawar and Prof. Firdos J. Khan, Multipurpose Manually Operated Automatic Spraying and Fertilizer Throwing Machine, International Journal for Research in Applied Science & Engineering Technology, ISSN: 2321-9653, Volume 5 Issue -4, pp 1453-1464, April 2017.
- Laukik P. Raut, Smit B. Jaiswal, Nitin Y. Mohite, Design, development and fabrication of agricultural pesticides sprayer with weeder, International Journal of Applied Research and Studies (IJARS) ISSN: 2278-9480 Volume 2, Issue 11, pp 1-8, Nov. 2013
- Veerasha G, Abdul Raheem, Abdul Kadeer Ansari, Dinesh Yadav and Md. Mainudin Ansari, Design and Fabrication of Multipurpose Agricultural Equipment, International Research Journal of Engineering and Technology, e-ISSN: 2395-0056, Volume: 05 Issue- 07, pp 912-914, July 2018
- Faijubhai Malek, Dipam Patel, Yash Padia, Mit Kundariya and Varun Jarsania, Mechanically Operated Cart for Pesticide Sprayer for Agriculture, International Journal of Innovative Research in Science, Engineering and Technology ISSN: 2347- 6710, Volume 5, Issue 5, pp 6704-6711, May 2016
- Shailesh Malonde, Shubham Kathwate, Pratik Kolhe, Roadney Jacob, Nishat Ingole and Rupesh D. Khorgade, Design and Development of Multipurpose Pesticides Spraying Machine, International Journal of Advanced Engineering and Global Technology ISSN No: 2309-4893 Volume 4, Issue-03, pp 1945- 1953, May 2016.
- Ahmad Suhaizi Mat Su and Desa Ahmad, Friction Coefficients of Selected Agricultural Soil and Agro-Products A Review, in conference Mytribos Symposium 2, pp.19-21, 8 Oct 2017

- Nitish Das, Namit Maske, Vinayak Khawas, Dr. S. K. Chaudhary and Er. R. D. Dhete, Agricultural Fertilizers and Pesticides Sprayers – A Review, International Journal for Innovative Research in Science & Technology ISSN: 2349-6010, Volume 1 Issue 11, pp 45-47, April 2015
- Prof. Basavraj R. Birajdar<sup>1</sup>, Prof. Mallikarjun B. Awate, Prof. Prasad N. Kulkarni, and Prof. Aditya D. Dhobale. Design and Fabrication of Fertilizer Spreading Machine, ISSN: 2321-9653, Volume 6 Issue 7, pp 238-245, July 2018.