

A Review on Power Quality Enhancement Using Custom Power Devices

Anita Y. Solanki ¹, Dr. Sanjay R. Vyas²

¹PG Scholar, LDRP Institute of Technology and Research, Gujarat, India

²Dr.Sanjay R. Vyas, Professor, Department of Electrical Engineering, LDRP ITR, Gujarat, India

Abstract - A Power Quality (PQ) is one of the most important aspects of power system. This paper presents brief review on various power quality issues and its mitigation techniques used at distribution side because various industrial and commercial consumer equipments are highly affected by power quality disturbances. With the proliferation of power electronics, most of the industrial and commercial consumers are incorporating power electronic based controlling devices which are very sensitive to quality of power. The sensitive devices/equipment may fail or malfunction due to PQ disturbances which in turn shut down the processing. Industrial consumers experience huge loss of revenue due to shutdown of production units. To mitigate such PQ issues, devices such as Active filters, Passive filters, Hybrid power filters and custom power devices (CPDs) are in practice. This paper reviews mainly three compensating CPDs; Distribution static compensator(D-STATCOM), Dynamic voltage restorer (DVR), and Unified power quality conditioner (UPQC). Their classification and main features are discussed in this paper.

Key Words: Power Quality, D-STATCOM, DVR, UPQC

1. INTRODUCTION

“Power quality is the concept of powering and grounding sensitive equipment in a manner that is suitable to the operation of that equipment”. There are various PQ disturbances like voltage sag, swell, harmonics, interruptions, noise and transients which result in damage or mal-operation of consumer’s devices. Custom power devices are becoming popular to mitigate such PQ issues. An increasing demand for high quality, reliable electrical power and increasing number of distorting loads may leads to an increased awareness of power quality both by customers and utilities. Since the pollution of electric power supply system is much severe at the utilization level, it is important to study at the terminals of end users in distribution systems. Evolution has been seen in custom power devices such as D-STATCOMs for power factor correction, voltage regulation, compensation of excessive neutral current, and load balancing; DVRs for mitigating voltage quality problems in transient and steady-state conditions; and UPQCs as a combination of D-STATCOM and DVR for mitigating current and voltage quality problems in a number of applications.

1.1 PQ Disturbances

With the proliferation of power electronics, most of the

Industrial and commercial consumers are incorporating power electronic based controlling devices such as ASDs, UPS, computers etc. which are highly sensitive to PQ disturbances. Some common PQ disturbances are categorized as;

(a) Voltage Sag

As per IEEE standard 1159-1995, voltage sag is defined as Decrease in rms voltage from 10% to 90% of nominal value for durations of 0.5 cycles to 1 minute.

(b) Voltage Swell

Voltage swell is a temporary increase in rms voltage of more than 10% of the nominal value at power system frequency which lasts from 0.5 cycles to 1 minute

(c) Interruptions

The complete loss of voltage (below 0.1 p. u) on one or more phase conductors for a certain period of time.

(d) Harmonics

Sinusoidal voltages or currents having frequencies that are multiples of the fundamental power frequency. Distorted Waveform comprises of fundamental frequency component and harmonic components. Harmonics are caused by nonlinear loads.

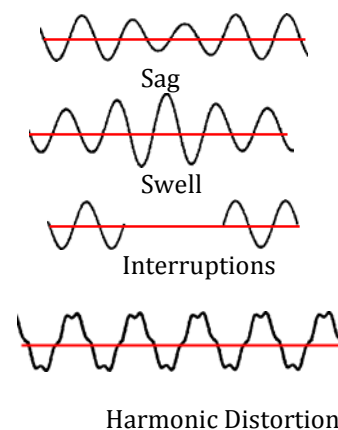

Fig.1 Waveform distortion associated with poor PQ

1.2 Causes of PQ Disturbances

The main causes of PQ issues are classified as natural and man-made in terms of current, voltage and frequency. Natural causes are mainly due to faults, lightning, storms and so on. Whereas man-made causes are due to loads and operations. Different nonlinear loads causing PQ disturbances are saturating transformers and loads using solid state controllers such as UPS, Adjustable speed drives, computers and so on. Operations which cause PQ problems are switching of system loads, capacitor banks and transformers.

1.3 Effects of PQ Disturbances on Users and Mitigation Devices

Consumer equipment/device may get damaged or malfunction due to poor quality power. These power quality problems cause failure of capacitor banks, increased losses in the distribution system, false metering, Relay and breaker malfunction etc.

To improve PQ efforts are made time by time in the name of passive filters (PF), active filters (AF), hybrid filters (HF) and custom power devices (CPDs). PFs are one of the good solutions to PQ problems, which can mitigate the harmonic distortions. However, these passive filters can provide only fixed compensations as well as resonate with the supply voltage, Due to these limitations their place has been taken by active filters. The AF can compensate the nonlinear load current of electrical systems: harmonics, reactive power etc. However, they are costlier solution for PQ improvements due to almost same rating as load. HFs have been also used for better performance with cost effective solution. There are various power electronic based devices are also incorporated to mitigate PQ problems at customer side, commonly referred as custom power devices.

2. CUSTOM POWER DEVICES

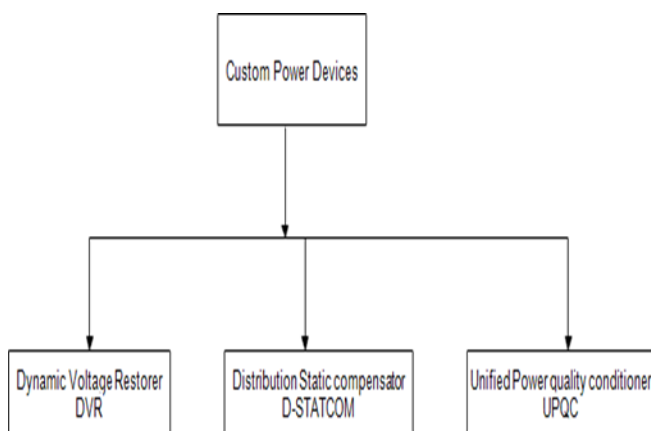

Fig.2 Different types of custom power devices

Custom power devices are referred as power electronic based controllers used for PQ enhancement at distribution

side. The power electronic controllers that are used in the custom power solution can be network reconfiguration type or compensating type. CPDs discussed in this review paper are Compensating type. Custom power devices can be classified on the basis of different topologies and the number of phases. For power quality improvement the voltage source inverter (VSI) bridge structure is generally used for the development of custom power devices, while the use of current source inverter (CSI) is less reported. The topology can be shunt (D-STATCOM), series (DVR), or a combination of both (UPQC). The second classification is based on the number of phases, such as single phase – two wire and three-phase- three or four wire systems.

2.1 Distribution Static Compensator (D-STATCOM)

The D-STATCOM basically consists of Voltage Source Converter (VSC), Energy Storage Circuit, coupling transformer connected in shunt with AC lines and associated control circuits. Multilevel converters are used commonly in practice.

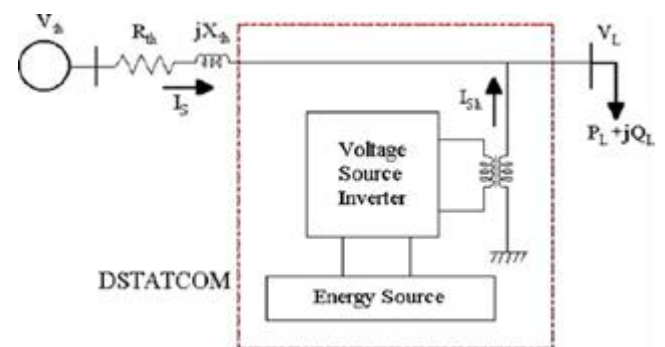

Fig.2.1 Schematic diagram of D-STATCOM

Fig.2.1 shows the schematic representation of the D-STATCOM. The VSC converts the dc voltage across the storage device into a set of three-phase ac output voltages. These voltages are in phase and coupled with the ac system through the reactance of the coupling transformer. Suitable adjustment of the magnitude and phase of the D-STATCOM output voltages allows effective control of active and reactive power exchanges between the D-STATCOM and the ac system. The VSC connected in shunt with the ac system of different topologies can be used for distinct purposes;

- (1) voltage regulation;
- (2) power factor improvement;
- (3) harmonics mitigation.

The D-STATCOM is used to regulate voltage at the point of connection. The control is based on sinusoidal PWM and only requires the measurement of the rms voltage at the load point

D-STATCOM is firstly classified based on converter either VSC or CSC. It can be secondly classified based on supply system namely, single-phase two-wire, three-phase three-

wire, and three-phase four-wire configurations and third classification is based on topology.

One of the major factors in advancing the D-STATCOM technology is the advent of solid-state devices and the latest control algorithms implementation such as PI, Fuzzy logic, neural network. With these advancements D-STATCOM has become fast device capable for PQ improvements even with continuously varying load.

2.2 Dynamic Voltage Restorer (DVR)

A dynamic voltage restorer (DVR) is a power-electronic converter-based device that has been designed to protect critical loads from all supply-side disturbances other than outages. DVR is a series active compensator which injects a voltage with desired magnitude and phase to control load side voltage even when the source side supply is distorted.

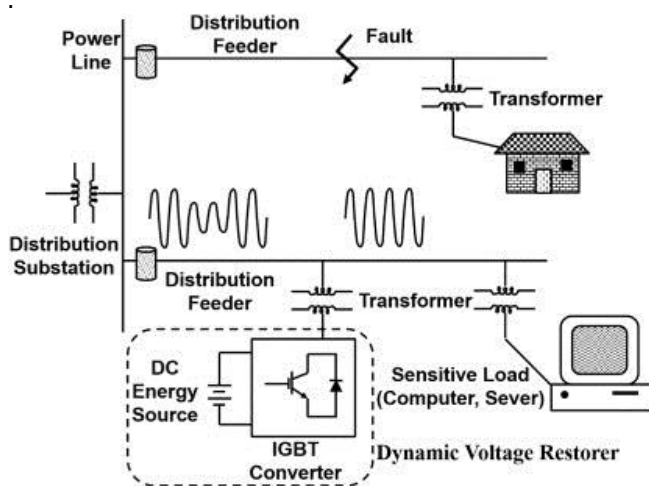

Fig. 2.2(a) DVR operating principle

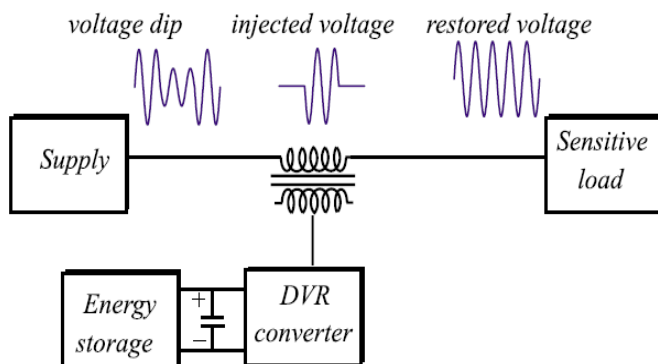

Fig.2.2(b) Schematic of DVR for voltage sag correction

As shown in fig. 2.2(a) the DVR consists of DC power sources, an IGBT converter, and an injection transformer which is connected in series with the power line and the sensitive

load. A voltage sag is experienced by a feeder connected with sensitive loads when another feeder has some fault. This voltage sag is corrected by injecting voltage with desired magnitude and phase in series with the line. Fig.2.2(b) shows the schematic diagram of DVR for voltage sag correction.

Classification of DVR is on the basis of topology, converter type and supply system. Converter based DVR can be VSC or CSC type. Topology based DVR can be half bridge, full bridge or transformer less type. Supply system-based DVR can be of single phase -two wire, three phase -three wire or three phase four wire type.

2.3 Unified Power Quality Conditioner (UPQC)

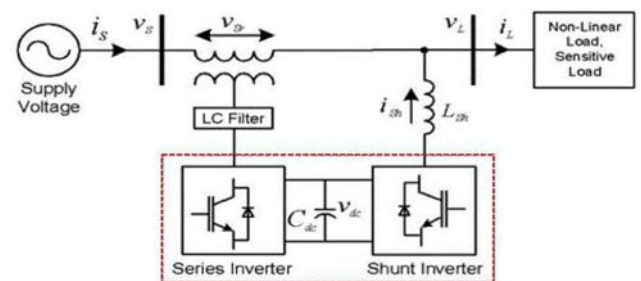

Fig.2.3 Unified Power Quality Conditioner

UPQC is a combination of shunt and series compensators for mitigating various PQ problems. As shown in fig.2.3 the power circuit of a UPQC consists of two VSCs joined back-to-back by a common DC link. The shunt device known as the DSTATCOM provides reactive power compensation along with load balancing, neutral current compensation, and elimination of harmonics (if required) and is positioned parallel to the consumer load. The series device known as the DVR keeps the load end voltage insensitive to the supply voltage quality problems such as sag/swell, surges, spikes, notches, or unbalance. The DVR injects a compensating voltage between the supply and the consumer load, and restores the load voltage to its reference value.

There are many control techniques and topologies reported for the control of UPQCs. It can be classified based on converter type, topology, supply system and control method. First classification is based on converter type either VSC or CSC. Second classification is Topology configurations that depends upon the type of connection between DVR and D-STATCOM. Third classification is based on supply system such as single phase two wire, phase three wire or three phase -four wire. The fourth classification is based on the method of control, such as UPQC-Q, UPQC-P, UPQC-S.

CONCLUSIONS

This paper gives brief review about various Power quality disturbances viz. Voltage sag, swell, flicker, Harmonics and their causes such as natural or based on switching

operations. PQ disturbances highly affect sensitive devices/equipment at consumer side such as ASDs, UPS, Computers etc. With the advent of Solid-state device-based process control huge loss of revenue has been reported by the industrial consumers due to poor power quality. This paper deals with study of custom power devices such as D-STATCOM, DVR and UPQC to enhance power quality at load side. Each CPD has different feature, classification and topology therefore one can choose appropriate device for mitigating particular power quality problem.

REFERENCES

- [1] "IEEE Recommended Practice for Monitoring Electric Power Quality," in IEEE Std 1159-1995.
- [2] Yash pal, A Swarup, Bhim singh, senior IEEE member "A Review of Compensating Type Custom Power Devices for Power Quality Improvement" IEEE paper ,2008.
- [3] M.H.Haque, "Compensation of distribution system voltage sag by DVR and D-STATCOM," in *Proc. IEEE Power Tech.*, vol.1, pp.5, Sept.2001.
- [4] Arindam Ghosh, Senior Member, IEEE, "Compensation of Distribution System Voltage Using DVR, *IEEE transactions on power delivery*, vol. 17, no. 4, October 2002
- [5] Olimpo Anaya-Lara and E. Acha, "Modeling and Analysis of Custom Power Systems by PSCAD/EMTDC", *IEEE transactions on power delivery*, vol. 17, no. 1, January 2002
- [6] S. S. Bhosale, Y. N. Bhosale, U. M. Chavan and S. A. Malvekar. "Power Quality Improvement by Using UPOC: A Review." 2018. ICCPCCT, Kannur. 2018, pp. 375-380, doi: 10.1109/ICCPCCT.2018.8574264.
- [7] Chanchal Katariya & Rakesh Shriwastava, "Power Quality Improvement By Using D-STATCOM: Review", *IOSR Journal of Electrical and Electronics Engineering*, pp 15-20,2014
- [8] D. R. Dobariva and P. A. Upadhyav, "Notice of Removal: Simulation and comparison between hybrid active power filter and shunt active power filter." *2015 International Conference on Electrical, Electronics, Signals, Communication and Optimization (EESCO)*, Visakhapatnam. 2015. pp. 1-6, doi: 10.1109/EESCO.2015.7253908.
- [9] Mr.Y.Prakash, Dr.S.Sankar, "Power Quality Improvement Using DVR in Power System," 2014 Power and Energy Systems: Towards Sustainable Energy (PESTSE 2014), 2014 IEEE.
- [10] Ravilla Madhusudan and G. Ramamohan Rao, "Modeling and Simulation of a Distribution STATCOM (D-STATCOM) for Power Quality Problems-Voltage Sag and Swell Based on Sinusoidal Pulse Width Modulation (SPWM)", IEEE- International Conference on Advances In Engineering, Science And Management (ICAESM - 2012) March 30, 31,2012
- [11] Power Quality Guidebook, by Tenaga Nasional Berhad, Malaysia,2018
- [12] N. G. Hingorani, "Introducing custom power," *Proc. IEEE Spectrum*, vol.32, pp.41-48, June1995.
- [13] C. Sankaran, "Power Quality," CRC Press, New York, 2001
- [14] Arindam Ghosh, Gerard Ledwich, "Power Quality Enhancement Using Custom Power Devices" Kluwer Press, 2002.
- [15] Bhim Singh, A Chandra, K Al-Haddad "Power quality problems and mitigation techniques", John Wiley and Sons Ltd, UK,2015
- [16] R. C. Dugan. M. F. McGranaghan. S. Santoso. and H. W. Beatv. "Electrical Power Systems Quality", Third Edition: McGraw-Hill Education, 2012.
- [17] "Innovative system solutions for power quality enhancement", ABB review ,1998