

Review on Isolated DC-DC Converter Fed DC Motor for Bidirectional Electric Vehicle

¹Hiral A. Vaja and ²Monika D. Patel

¹Department of Electrical Engineering, M. Tech student, Atmiya University, Rajkot, India

²Department of Electrical Engineering, Asst. Professor, Atmiya University, Rajkot, India

E-mail: ¹hiralvaja001@gmail.com, ²mdpatel@aits.edu.in

ABSTRACT - This paper presents a review on isolated dc-dc converter fed dc motor for Bidirectional Electric Vehicle. An Isolated dc-dc converter is implemented through bi-directional full bridge converter having transformer which segregate input and output. The input side is the main battery side with relatively high voltage up to 310V and the output side with low voltage of 220V to achieve step down voltage power conversion. A dc-dc converter developed is composed with two stages inverter and rectifier stage. Sinusoidal pulse width modulation technique is used for triggering the switches. This paper presents switching technique applied in full-bridge converter. This technique reduces the over voltage across semiconductor devices. Simulation results are verified by MATLAB/Simulink.

Keywords: Isolated DC-DC Converter; Electric Vehicle; power converter; Isolation Transformer; Separately Excited DC Motor; PWM technique; snubber less converter.

1. INTRODUCTION

Researchers have studied diverse techniques to enhance performance and strength density of EV chargers [1]. The dc output can be regionally generated by using renewable power resources such as sun PV gadget, wind energy technology, fuel cell, and so on, and can be linked to a commonplace dc bus. In DC applications, some new technologies, e.g., micro-grids, renewable resources, power storages and solid state transformers are primarily based on power electronics converters.

Among them, the isolated bidirectional DC-DC converter is one of the most famous [2-3]. Lots of electric equipment in automobile employs power electronics technology with semiconductor power devices. To respond above demand, electronics with higher switching frequency is one of the key technology[4]. Traditionally, the isolated bidirectional DC-DC converter is one of the most popular converter. Bidirectional converters are appropriate for dc power flow in both directions. Isolated DC-DC converters have excessive voltage isolation from quite a few hundreds to thousand volts relying on the kind of standards. In this review, two different configurations are discussed. fig. 1 is Block diagram of an isolated bidirectional DC-DC converter.

There are two configurations, one is full-bridge inverter and another is single-phase rectifier. Two converter connect with isolation transformer via interconnected DC link.

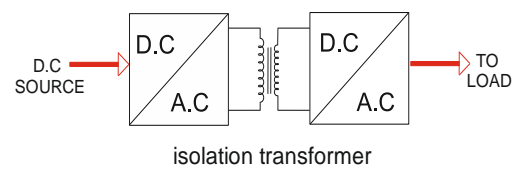

Fig.1 Block Diagram of the Full-Bridge Converter.

2. OPERATION AND CONTROL PRINCIPLE

2.1 Converter Topology

Bidirectional dc-dc converters can be divided into two parts: (1) isolated and (2) non-isolated converters. The isolated converter increases system safety and reliability even though it is more expensive than the non-isolated converter. Commonly, single-phase inverters use half bridge or full bridge configuration. Mostly, full-bridge configuration is used in high-power applications due to its low voltage and current stress, minimum VA rating of the high-frequency transformer, and minimal ripple currents at the output filter.[5]. Fig.2 illustrate an isolated bidirectional DC-DC step down converter, as mentioned in earlier circuit is divided into two parts. One is full bridge inverter and another is single phase Rectifier. Two converter connected with isolation transformer via interconnected dc link.

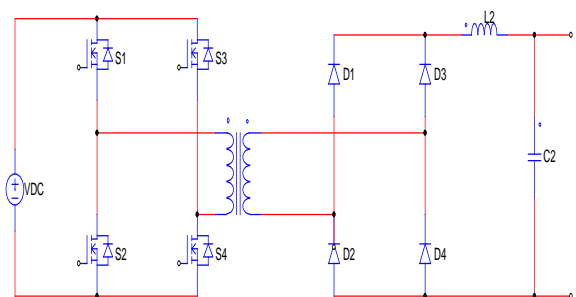

Fig.2 Full-Bridge isolated DC-DC Converter.

The primary side is the main battery side with relatively high voltage up to 310V and secondary side is output side with low voltage of 220V. To achieve step down voltage DC DC converter is composed with two stage inverter and rectifier. When a switch turns ON and OFF alternatively, charged capacitor work as the energy storage devices and then after some time release energy. Charge capacitor energy is now delivered to the load, because of this ripple generate at the output side. Ripple magnitude is dependent on the capacitor, load resistance and switching frequency. Constant output voltage required for all applications, so ripple magnitude should be minimum. There are various methods for minimizing ripple magnitude. Out of all the method PWM method are used for minimizing the output ripple magnitude [6].

For simplifying the circuit following factor should be considered. 1) All semiconductor devices and an isolation transformer considered ideal; 2) The dead band between the switches represents a time that is small enough to neglected.

2.2 Working principle

Assuming that V_{in} is the input and V_o is the output, the circuit operates as voltage reducer and acts like non-isolated buck converter in four stages. The principle of the topology is introduced in this mode. the working process of each cycle is divided into four modes. As shown in Fig. 3, dc supply V_{in} powering the bi-directional converter. All the switches on the primary side are gated at duty ratio 0.77 Fig.3 show the various stage of operation during one switching time period T . fig.4 show the theoretical waveforms of converter. Where, V_T is transformer across secondary voltage.

(1) Mode 1 [t_0-t_1]: In this mode at interval [$t_0 - t_1$] switch S_1 and S_4 are turned ON. While S_2 and S_3 are turned OFF. A V_{in} voltage appears across the primary winding and Secondary winding of transformer side semiconductor diode D_2 and D_3 are forward bias and provide rectification to load as a result of charging inductor L and capacitor C .

Assume a V_{in} voltage across the block switch at primary side while reverse diode present voltage equal to V_o . V_L is voltage across inductor and i_L is current through inductor.

$$V_L = V_{in} - V_o \tag{1}$$

$$i_L = i_c - i_o \tag{2}$$

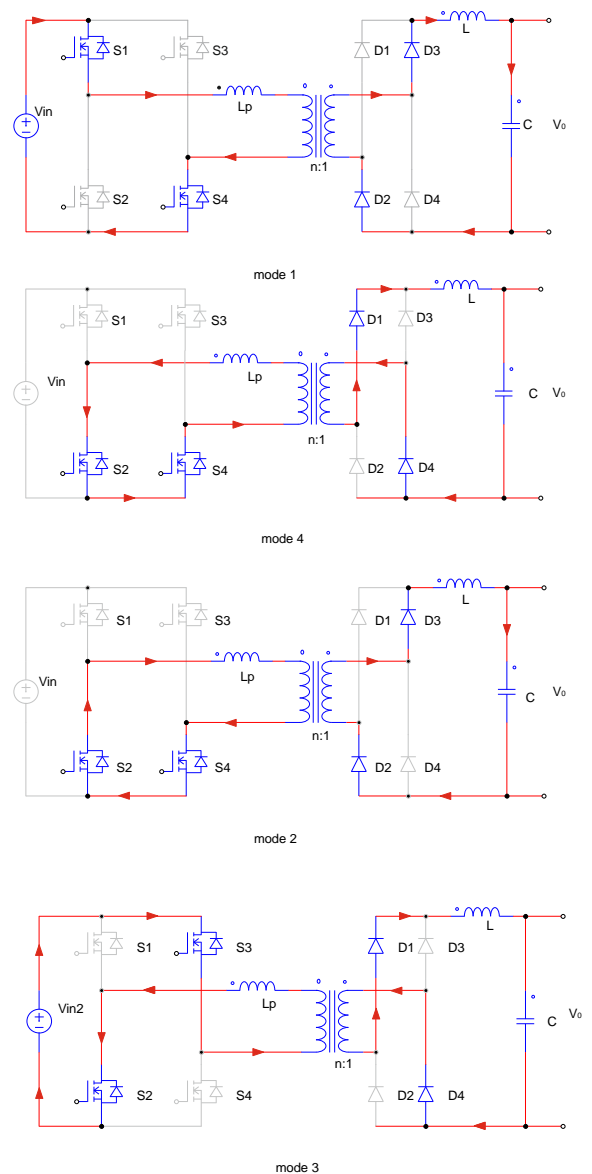

Fig.3 Modes of Operation for Bi-Directional Isolated Converter

(2) Mode 2 [t_1-t_2]: In this mode, the Switch S_2 and S_4 are turned ON. During this mode Zero voltage is given to transformer no power transfer to primary side. The energy stored in inductor result in freewheeling of the current equally through the diode D_2 and D_3 due to the excess current at the transformer switch S_2 and S_4 is turned On, while S_1 and S_3 is turned OFF. It is the best possible way to avoid over voltage across the blocked semiconductor device.

$$v_L = -v_o \tag{3}$$

$$i_L = i_C - i_0 \quad (4)$$

TABLE I

STAGES OF OPERATION OF THE CONVERTER IN BUCK MODE

State S	Switching interval			
	t ₀ -t ₁	t ₁ -t ₂	t ₂ -t ₃	t ₃ -t
S ₁	ON	OFF	OFF	OFF
S ₂	OFF	ON	ON	ON
S ₃	OFF	OFF	ON	OFF
S ₄	ON	ON	OFF	ON
D ₁	OFF	OFF	ON	ON
D ₂	ON	ON	OFF	OFF
D ₃	ON	ON	OFF	OFF
D ₄	OFF	OFF	ON	ON

(3) Mode [t₂-t₃]: In this mode, a switch S₂ is continuously turned ON at t₂ while switch S₁ and S₄ are turned OFF and presents a voltage equal to V_{in}. The operation is similar to that during interval t₀-t₁. but now negative voltage applied to the transformer. In this mode diode D₁ and D₄ conducts and provide secondary side rectification while D₂ and D₃ are blocked across the voltage equal to V_o. Inductor current increase again as the voltage across inductor increases so, inductor and capacitor charged again. for this mode equation 1 and 2 are valid.

(4) Mode [t₃-t]: The converter operation during this interval is closely resembles to the interval of (t₁-t₂) again Zero voltage applied to the transformer. S₂, S₄ remains On and S₁ and S₃ are turned OFF. An inductor and capacitor release the energy. Diode D₁ and D₄ are in conduction. Equation 3 and 4 are valid. For sufficient operation of converter average voltage of transformer is should be zero. This is the best way to avoid core saturation.

$$V_L = (V_{in} - V_0)DT + (-v_0)(1 - D)T = 0 \quad (5)$$

Note that output voltage depends on only the input and duty ratio D. If the input voltage fluctuates the output voltage can be regulated by adjusting the duty ratio appropriately.

It must be noted that during the interval [t₀-t₁] and [t₂-t₃] an inductor and capacitor is charged due to this instances are referred to as T_{ON}. Interval [t₀-t₁] and [t₂-t₃] are equal for this reason, the duty cycle of converter is $D = \frac{2 \cdot T_{ON}}{T}$

2.3 Design of LC Filter

The equation that determine output filter is found according to theoretical analysis presented in [7] [8].

Inductance is given by,

$$L = v_L \cdot \frac{\Delta t}{\Delta i_L} \quad (6)$$

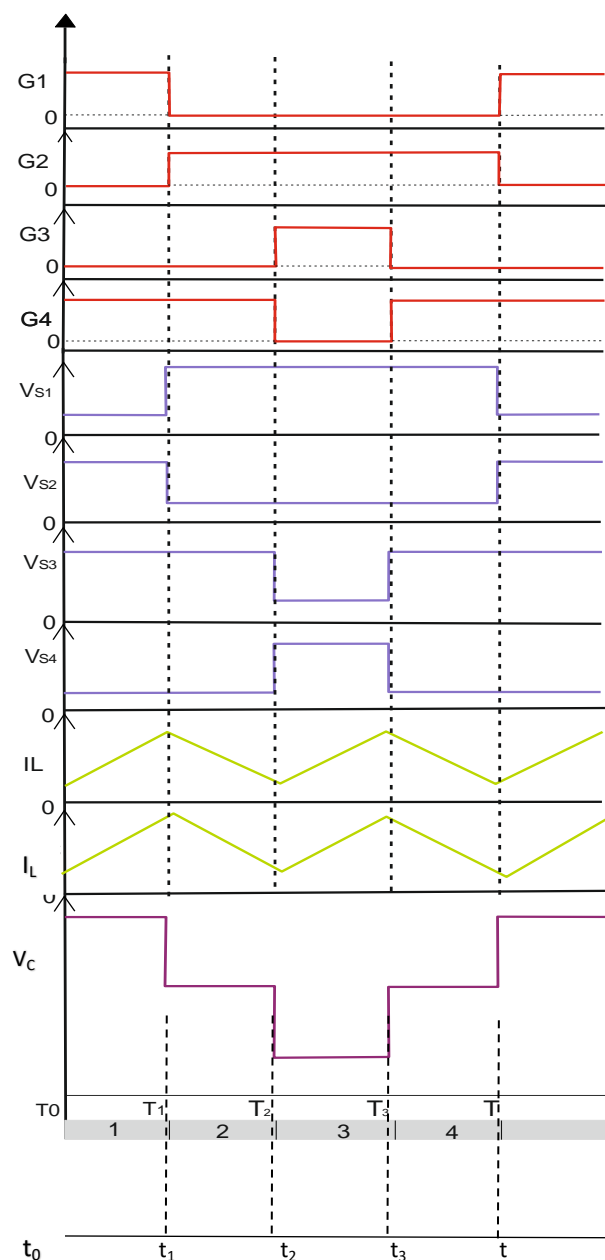

fig.4 wave form of isolated BI directional DC DC Converter

In mode 2 and 4 converter is turned OFF so voltage across inductor is V_o . As stated in equation 3 this condition occurs in mode 2 and 4. For the time referring to $(1-D) T/2$. Due to this it is possible to replace the voltage in inductor v_L and Δt equation (6).

$$L = \frac{v_o(1 - D)}{2 \cdot f \cdot \Delta i_L} \quad (7)$$

Where, f is switch frequency. The capacitor value is derived by charge variation given by,

$$\Delta Q = C \cdot \Delta v_C \quad (8)$$

In converter capacitor is charged $1/4$ period of operation and the time of current is equal to $\frac{\Delta i_L T}{2}$ so, equation (6) is given by,

$$\begin{aligned} \Delta Q &= \frac{1}{2} \cdot \frac{T}{4} \cdot \frac{\Delta i_L}{2} \\ &= \frac{T \cdot \Delta i_L}{16} \quad (9) \end{aligned}$$

From equation (7) capacitor value is,

$$C = \frac{\Delta Q}{\Delta v_C} = \frac{T \cdot \Delta i_L}{16 \cdot \Delta v_C} \quad (10)$$

Equation (7) is that occurs at the moment when converter is turned OFF. In result time period is $(1-D) T/2$. And $\Delta i_L = \frac{v_o}{L}$

Therefore, the capacitor value is

$$C = \frac{v_o(1 - D)}{32 \cdot \Delta v_C \cdot L \cdot f} \quad (11)$$

The design of converter has the following parameter (Assuming all ideal component).

TABLE II: SPECIFICATIONS OF THE SIMULATION

Parameter	Value
DC input voltage (V_{in})	310v
DC output voltage (V_o)	240v
duty cycle	0.774
Transformer	1KVA
Ripple voltage Δv_C (%)	12
Ripple current Δi_L (%)	0.833
Switch frequency(f)	20kHz
Inductor(L)	2.1026mH
Capacitor(C)	3.3630mF
DC motor	240v,5HP,1750rpm, 4KW

3. SIMULATION RESULTS

In Fig. 4(a) dc voltage is applied to inverter. By using SPWM method. Switching provided to the high frequency isolated transformer. L and C filter is used to eliminate ripple in output. The operation of isolated bi directional dc-dc converter has been verified through the simulation result. It should be noted that simulation is done only for motoring mode.

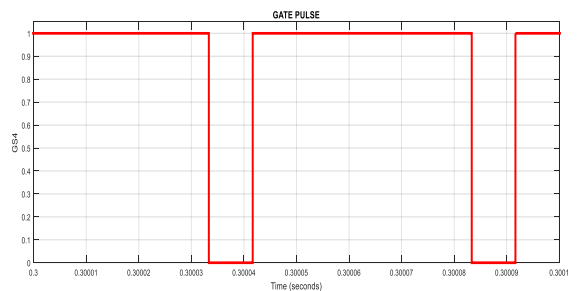
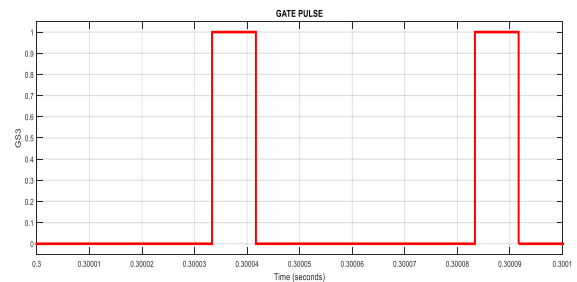

Fig. 4(b) Simulated result of the Gate pulses

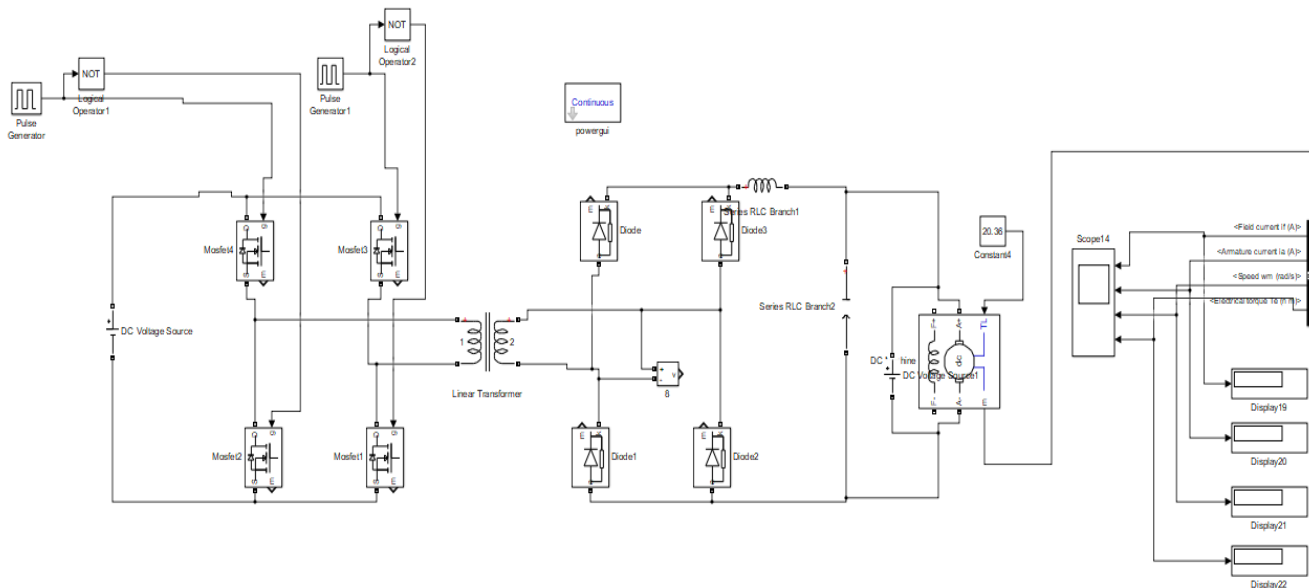

Fig. 4(b) Simulation model of an isolated dc-dc converter

Fig.4(c) show the switching pulse wave form of S_1 , S_2 , S_3 and S_4 . Fig. 4(c) shows that switch voltage wave forms of bridge inverter when the 310V is applied.

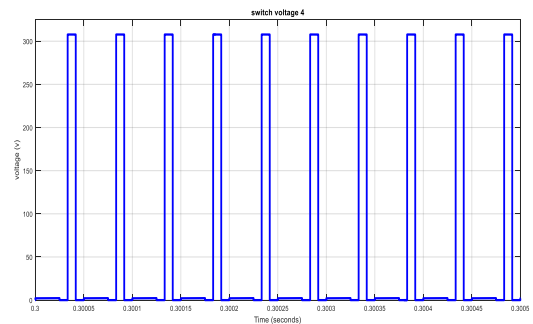
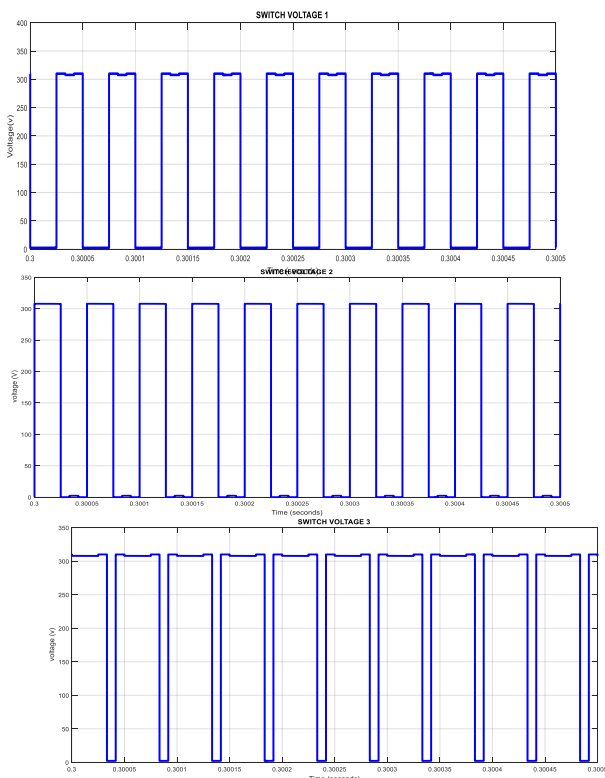

Fig.4(c) Simulated result of the switching voltage

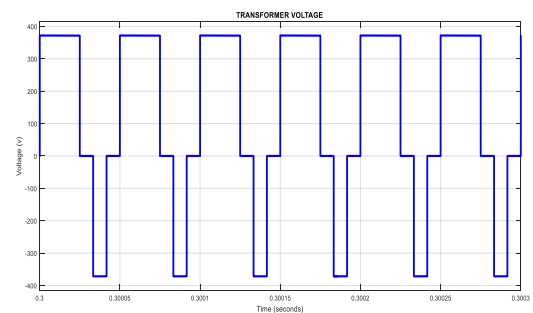

Fig. 4(d) Simulated result of transformer secondary voltage

Fig. 4(d) is the wave form of the output voltage of

steady state transformer when circuit operate from 310V to 220V. If the input voltage is changed the output voltage varies according to change in voltage.

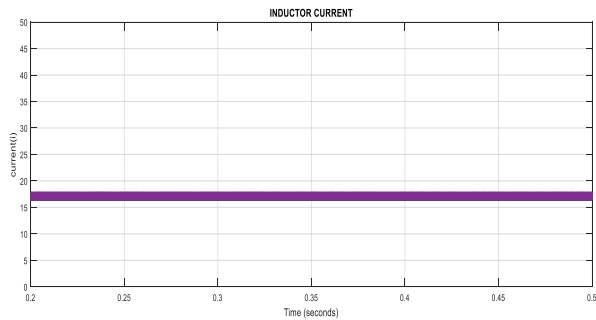

Fig.4(e) inductor current

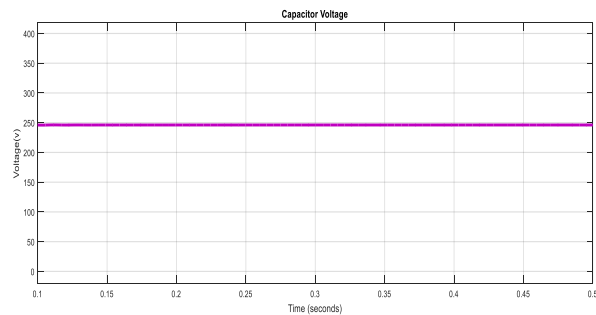

fig. 4(f) capacitor voltage

Fig.4 (e), (f) shows the inductor current and capacitor voltage when the input voltage is 310V. It can be seen that the dynamic performance is good.

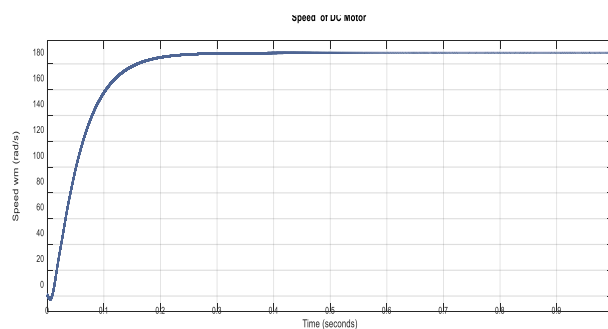

fig. 4(g) speed of dc motor

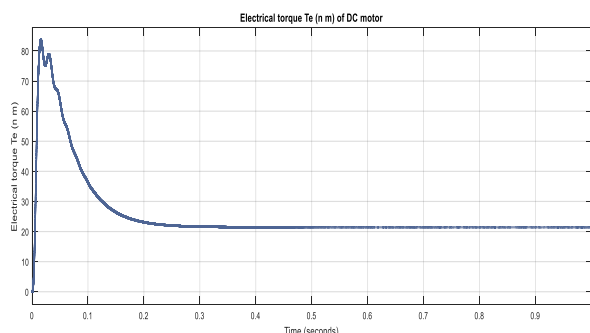

fig.4(h) Electrical torque

fig.4(i) field current of dc motor

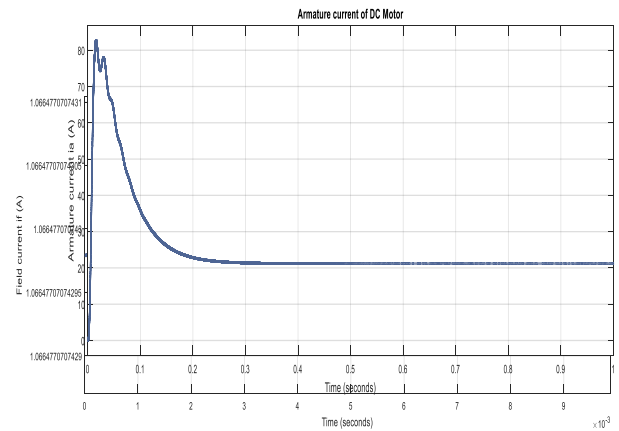

fig.4(j) Armature current of dc motor

4. CONCLUSION

This paper present analysis and design of isolated bi directional converter. Firstly, the topology and working principle of converter introduced and then design of converter is discussed. This configuration is providing low ripple voltage and current. For this method SPWM technique is used for minimizing the output ripple magnitude.

REFERENCES

- [1] He, Peiwen, and Alireza Khaligh. "Comprehensive analyses and comparison of 1 kW isolated DC-DC converters for bidirectional EV charging systems." *IEEE Transactions on Transportation Electrification* 3.1 (2016): 147-156.
- [2] Karthikeyan, V., and Rajesh Gupta. "Multiple-input configuration of isolated bidirectional DC-DC converter for power flow control in combinational battery storage." *IEEE Transactions on Industrial Informatics* 14.1 (2017): 2-11.
- [3] Ge, Junjie, Xing Huang, and Hailian Xie. "Fast equivalent model of isolated bidirectional dc-dc converters for dc microgrid study." *IECON 2015-41st Annual Conference of the IEEE Industrial Electronics Society*. IEEE, 2015.
- [4] Matsumori, Hiroaki, et al. "Isolated DC-DC Converter utilizing GAN power device for Automotive Application." *2019 IEEE Applied Power Electronics Conference and Exposition (APEC)*. IEEE, 2019.
- [5] Tan, Nadia ML, Takahiro Abe, and Hirofumi Akagi. "Topology and application

- of bidirectional isolated dc-dc converters." 8th International Conference on Power Electronics-ECCE Asia. IEEE, 2011.
- [6] Ho, Charlotte Yuk-Fan, et al. "Optimal PWM control of switched-capacitor DC-DC power converters via model transformation and enhancing control techniques." IEEE Transactions on Circuits and Systems I: Regular Papers 55.5 (2008): 1382-1391.
- [7] Book title: Power Electronics, Author Name: Daniel W. Hart, Publisher Name: McGraw-Hill, Year: 2011.
- [8] Carvalho, Edivan Laercio, et al. "Analysis, design and implementation of an isolated full-bridge converter for battery charging." 2017 Brazilian Power Electronics Conference (COBEP). IEEE, 2017.