

SMART ELECTRICITY DISTRIBUTION CONTROL AND RELAY SYNCHRONIZATION SYSTEM

YOGESH. B. GIRASE¹, MAYUR. N. PATIL², BIPASA PATRA³

¹Scholar, Electrical Engineering, GHRIEM, Jalgaon, Maharashtra, India

²Scholar, Electrical Engineering, GHRIEM, Jalgaon, Maharashtra, India

³Assistant Professor, Electrical Engineering, GHRIBM, Jalgaon, Maharashtra, India

Abstract -: Power distribution system consists of various load lane. Suppose these distribution systems consist of 3 load lane which is attached to the same distribution line. If due to some problem, load lane one is off but another load lane also connected to the same line so that these two load lanes also become off if there is no problem in these load. So that main part of our project is to "Relay co-ordination for electrical distribution system using PLC for stand by supply arrangement". In these project when one load lane is off, the other load lane which is attached to the same line will be automatically on through relay.

Key Words: programmable logic controller (PLC), Current transformer (CT), Relay, instrument transformer (IT), Rectifier etc.

1. INTRODUCTION

PLC can help in achieving complete automation. In above years there are many techniques are done by our engineers with the help of relay synchronization. When PLC was not seen, control, sequencing, and safety interlock logic for manufacturing automobiles was accomplished using hundreds or thousands of relays, cam timers, and drum sequencers and dedicated closed-loop controllers. The process for updating such facilities for the yearly model changeover was very time receiving and expensive, as electricians needed to individually rewire each and every relay.

The main purpose of this project is to rescue the distribution transformer in power system network against the internal and external faults. In the past the movements of industrial machines were controlled by relay cards. These relay-controlled systems were replaced by PLC. The primary function of the PLC was to perform the linear operations that were previously implemented with relays. Overloading of transformer beyond the rating transformer rise in temperature of both transformer oil and over current fault accrue in second side of distribution transformer. as the winding temperature increases it will

increase the stress on the insulation and then insulation degrade and may fail power system external faults to transformer can increase or decrease voltage transformer which lead to over voltage.

1.1 WPL SOFT

WPL Soft is a programming software that are made for the Delta DVP-PLC series used under WINDOWS. also for general program planning and other general functions (e.g. cut, paste, copy, multi-windows, etc.) Today, PLC is being used in every process and manufacturing industries, apart from knowing the wires and connections, anyone should know the way to do PLC programs.

PLC Programmable logic controller is an industrial solid state computer that monitors input and output, and makes logic-based decisions for automated processes that's make work easy.

Delta PLC is a control system using electronic operation. It's easy storing procedures, handy expanding principles, functions of sequential/position control, timed counting and input/output control are widely applied to the field of industrial automation control.

WPLSoft is a program-editing (logic development) software made for the Delta DVP-PLC series used under WINDOWS. And this course is covering complete programming of PLC Model DVP-14SS2 of Delta PLC.

After doing this course, you can softly program the other PLC. This software is also used for all the PLC series. And the instructions will be the same.

This course will teach you step by step How to make a Ladder Logics and Programming to any industrial process Control.

We have made explanation by Real Time LIVE Camera and Designing Software to understand the concepts clearly.

2. LITERATURE SURVEY

In2007, Roberto Benato and Roberto Caldon, explain that the paper focuses the attention on the need for new

strategies of control protection of future distribution networks with high penetration of distribution generator and point out how plc could have a key roll among the technologies that are expected to be applied. (APPLICATION OF PLC FOR THE CONTROL AND THE PROTECTION OF FUTURE DISTRIBUTION NETWORK) [2]

In2016, Anu Priyaa K and Sabari Karthiga T C, proposed that when to protective apparatus installed in series have certain characteristics, which provide a specified operating sequence, they are set to be coordinated or selective. The objective protective relay coordination is to achieve selectivity without loosening sensitivity and quick fault clearance time. (RELAY COORDINATION FOR DISTRIBUTION SYSTEM)

In2019, Mr. Rangrez Mushtaque, Mrs. A. N. Shewale, Mr. R.R. Karhe. Concluded that In these project when one load lane is off, the other load lane which is attached to the same line will be automatically on through relay. (PLC BASED RELAY COORDINATION SYSTEM FOR SMART ELECTRICITY DISTRIBUTION SYSTEM)

In2015 T. Vignesh, J. Kirubakaran proposed that in this project the basic idea behind substation control project the switchyards in substation. In substation many relay and circuit breaker are used when any one breaker is trip because of the problems', we can monitor and control SCADA window so if power consumption increases then substation monitoring is important for the proposed of controlling the hardware and software optimization with the help of PLC ladder logic system. (AUTOMATION BASED POWER TRANSMISSION CONTROL STATION USING PLC AND SCADA)

In2014 Gavali Amit Bhimrao, Patil Mahadev S. described that how the present automation system come into existence through its various stages. in the past automation is done through relays and contactor logics. Since the innervation is more, the scope of error was also more. But with the advent of microprocessors and micro controllers several new tools PLCs come In to use. These have reduced human intervention. Which in turn has increased accuracy, precision and efficiency.

In2008 Dhanraj Shiv and Kamal Niwaria. Described that PLC in industrial automation. PLC controllers in today's day are staple mechanism to controller operation of large number of machine and device in the industry. (A STUDY OF PROGRAMMABLE LOGIC CONTROLLERS (PLC) AND GRAPHICAL USER INTERFACE: A SURVEY)

In2018 Ajit B. Bachhav, Nikhil S. Sarode, Ms. Harshhdda Gagre, Ms. Dipti Shirsath, Rajashree S. Kadam. Proposed that Transmission line are the important factor of the power system. Transmission and distribution lines as good contribution in the generating unit and consumers to obtain the continuity of electric supply. (OVERHEAD LINE PROTECTION WITH AUTOMATIC SWITCH BY USING PLC AUTOMATION SWITCH BY USING PLC AUTOMATION)

In2019 Rajan V. Patel, Snehal B. Jadhav, Vikiraj R. Kadale, Bhagyshri S. Walzade. Concluded that Fire is one of the main caused of trouble in long tunnels and its effect are obtain severe also because of the produced smoke and toxic gases. (TUNNEL AUTOMATION USING PLC)

3. PROPOSED TOPOLOGY

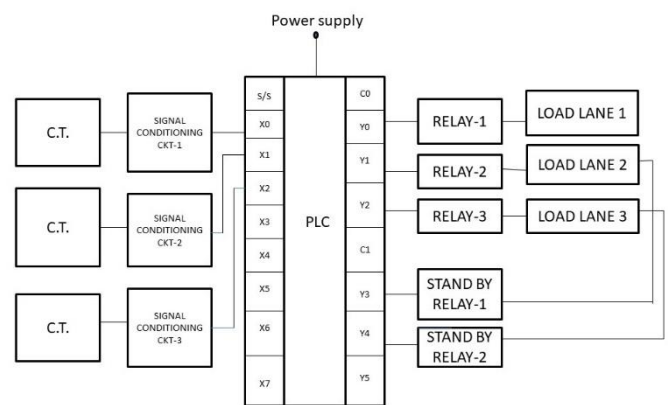

3.1 CURRENT TRANSFORMER (CT)

A transformer is a device that is used for the transformer of current from a higher Value into a proportion angle current to a lower value. It transformer the high voltage current into the low voltage current due to the which the heaving current flows through the transmission line. Is safely mentioned by the ammeter.

The current transmission (CT) is used with the AC incitement, meter or control apparatus where the current to be measured is of such magnitude that the meter or sufficient current carrying capacity.

The primary and secondary current of thr CT are proportional each other, the Ct is used in meter for measuring the current up to 100 amperes.

3.2 RELAY

The relay is the device that open or close the contact to cause the operation of the other electric control. It defects the understanding condition with an assigned area and gives the commands to the ckt breaker to disconnect the affected area. Thus protect the system from damage.

It works on the principle of an electromagnetic attraction when the ckt of the relay sense the fault current, it energies electromagnetic field which produce temporary magnetic field, This magnetic field moves the relay armature for opening or closing the connection.

3.3 PLC

It is a digital electrical device used in commercial and industrial application. A PLC monitors the input and make a decision based on its program and control output to automation a process or machine. When the PLC program execute the calculations of formula, sequence, counter, timer and logic according to the status of value. The mostly used program language are plc ladder diagram.



4 REFERENCES

1. R. Hemminger, L.J.Gale, F.Amoura, B. O'Neal: "The effect of Distribution Transformers on Distribution Line Carrier Signals", IEEE Trans. on Power Delivery, Vol. PWRD-2, No. 1, January 1987, pp. 36-40.
2. R.Benato, R.Caldon, F.Cesena: "Carrier Signal-Based Protection To Prevent Dispersed Generation Islanding On MV Systems", Proceedings of 17th International Conference on Electricity Distribution, CIRED2003, 12-15 May 2003, Barcelona, Spain.
3. R. Benato, R. Caldón, F. Cesena: Application of Distribution Line Carrier-based protection to prevent DG islanding: an investigating procedure, Proceedings of IEEE Bologna Power Tech'03 Conference, 23-26 June 2003, Bologna, Italy.
4. Dharmendra Kumar Singh, Dr. S. Gupta "Protection Of Power System By Optimal Coordination of Directional Overcurrent Relays Using Genetic Algorithm" International Journal of Modern Engineering Research (IJMER) Vol. 2, Issue.1, pp. 326-331, Jan-Feb 2012.
5. H.H.Zeineldin, Y.R.Mohamed, V.Khadkikar, And V.Pandi, "A Protection Coordination Index for Evaluation Distributed Generation Impacts On Protection For Meshed Distribution Systems," Ieee Trans. Smart Grid, vol.4, no.3, pp. 1523-1532, sep:2013.
6. Hima A. Patel, Vaibhav M. Sharma, Anuradha Deshpande "Relay Coordination Using Etap" International Journal of Scientific &Engineering Research, Volume 6, issue 5, may-2015.
7. Karol Rastocny, Juraj Zdansky, Jozef Balak, Peter Holecko University of Zilina, Faculty of Electrical Engineering Department of Control and Information Systems Univezitná 8215/1, 010 26 Zilina, Slovak Republic, "Effects of Diagnostic on the Safety of a Control System Realised by Safety PLC" IEEE Trans.. Power Electron. IEEE 2016. PP. 462-467.
8. Awadallah Sulieman Rahama and Dr. Dalia Mahmoud Department of Control, Faculty of Engineering, Al Neelain University, Khartoum, Sudan, "Control of Induction Motors by Using Programmable Logic Controllers (PLC)," International Journal of Science and Research (IJSR) Volume 5 Issue 5, May 2016 PP 1923-1926.
9. Akansha Dubey and Dr. Jyoti Shrivastava M.Tech (Power System), Shuats, Allahabad, India Assistant Professor , Electrical Engineering Dept. , Shuats , Allahabad, India, "REAL-TIME MONITORING, CONTROL &PROTECTION OF TRANSFORMER USING PLC AND SCADA" International Research Journal of Engineering

- and Technology (IRJET) Volume: 04 Issue: 05 May 2017 PP 2250–2252.
10. Mohammad khan J. Yusufjai¹, Chintan H.Vekariya², Rajat A. Joshi³, Manan M. Desai⁴ Students, B.E - Electrical Engineering, 4 Assistant Professor Dr. Subhash Technical Campus, Junagadh, Gujarat, "PLC And SCADA Based Load Security System," International Journal of Engineering Development and Research , 2017 IJEDR | Volume 5, Issue 2 | ISSN: 2321-9939 PP 115–119.
11. Bipasa Roy Patra "Smart electricity generation with solar technology - A Transformation", IJERECE, ISSN:2394-6849, June 2017.
12. Ajit B. Bachhav, Nikhil S. Sarode, Ms. Harshaddha Gagre, Ms. Dipti Shirsath, Rajashree S. Kadam, "OVERHEAD LINE PROTECTION WITH AUTOMATIC SWITCH BY USING PLC AUTOMATION," International Research Journal of Engineering and Technology (IRJET), Volume: 05 Issue: 03 | Mar-2018 PP 2613–2616.
13. Poonyapa Sookrod and Paramet Wirasanti Dept. of Electrical Engineering Fact. Of Engineering Chiang Mai University Chiang Mai, Thailand "Over current Relay Coordination Tool for Radial Distribution Systems with Distributed Generation". 2018 5th International Conference on Electrical and Electronics Engineering 2018 IEEE PP.13-17.
14. Bipasa Roy Patra "Sustainable trends & Necessity of improving power quality for future smarter nation by smart grid", International journal of innovations in engineering and science, ISSN: 2456-3463, April 2018.
15. Bipasa Bimalendu Patra "Smart Grid - Sustainable Shaping of the Future Smarter Nation", International Journal of Emerging Technology and Advanced Engineering, First International Conference on Innovations & Engineering, Volume 8, Special Issue 10, Oct 2018 (ISSN 2250 – 2459 (Online)), pg. 101-107.
16. Prafulla Desale " A review of smart metering & Energy management in smart grid " International conference on "cyber physical system & its application" ICCPSA, 6TH-7TH Feb 2019.
17. Vipeen Joshi, Prafulla Desale , "Real Time Electrical Parameter Monitoring and Protection System for Transformer" , IJSRD , Volume 7 Issue 3 May 2019.
18. Bipasa Bimalendu Patra "Necessity for future smarter nation with Sustainable Trend- Smart Grid", PRATIBHA: International Journal of Science, Spirituality, Business and Technology (IJSSBT) ISSN (Print) 2277-7261.
19. Bipasa Patra, "Comprehensive Topological Analysis of Solar Integrated Multilevel Inverter for Power Filters", Springer indexed- International Conference on Smart Technologies for Energy, Environment & Sustainable Development [ICSTEESD 2020], organized by G H Raison College of Engineering, Nagpur on dated 4-5, December 2020.
20. Adesh P. Tadas, Kapil S. Tadas, Yogesh A. Tayde, Akshata Kirtiwar, "Off Grid Solar PV System", IRJET, Vol 07, Issue 09, Sep 2020.
21. Bipasa Patra and Dr. Pragya Nema, "Analysis of Solar Integrated Multilevel Inverter for Smart Grid Power Filters"- 2021 First IEEE International Conference on Advances in Electrical, Computing, Communication and Sustainable Technologies (ICAECT 2021), organized by Shri Shankaracharya Technical Campus, Bhilai, Chattisgarh on dated 19-20, February 2021.

5 Authors



Yogesh B. Girase.
BE Electrical (pursuing).



Mayur N. Patil.
BE Electrical (pursuing)

**Bipasa Patra.**

Head of Department
Electrical Engineering Dept.
G H Rasoni Institute of Business
Management, Jalgaon
BE (Electrical Engineering) from
NMU
M TECH (VLSI) from WBUT
M TECH (Electrical Power system)
from RGPV
P hd (Pursuing in Electrical
Engineering) from Oriental
University Indore
Teaching Experience of 11 years.