

DEVELOP LASER SECURITY SYSTEM USING ARDUINO

Mr. J.A. Dharne¹, Shreyash Dongare², Santosh Dhisale³, Atesh Dongare⁴

¹Prof. Dept. of Electronics and Telecommunication Engineering, Amrutvahini Polytechnic, Sangamner, India

^{2,3,4}Students, Dept. of Electronics and Telecommunication Engineering, Amrutvahini Polytechnic, Sangamner, India

Abstract – Technology develops day by day in the world. Now days the crime gang also improves their technology to carry out their operation. So technology of security should be modern with time to protect the world from crime. We decide to make a security issue as our project. In this project we have used laser beam to cover a large area. We know laser light goes to long distance without scattering effect. It's additionally obvious just at source and occurrence point, in any case invisible. These two properties help us to develop a modern security system, which may name as "Laser Security System." When any person or object crossover the laser light, automatically the buzzer starts ringing. Laser beam goes through long distance without scattering effect and the ray is almost invisible. The project involves the use of Arduino Nano, Laser light, Buzzer, LDR and a simple program. With this equipment's we can easily set up a security alarm anywhere for unwanted intruders. A Laser Security System goes about as a standalone system, which makes sound or commotion when it distinguishes any sporadic action or can be part of a much bigger security or any other automation system which can alert owner.

Key Words: Laser Light, LDR, Buzzer Alarm, Security System, Arduino Nano.

1. INTRODUCTION

Security is a most important factor in day to day life. Need of security is the basic necessity of every individual. The feeling that we are safe and everything around us is all right is imperative for a peaceful living. Be that as it may, in this unsafe world, when crime, terror and dangers are on their pinnacle, how might one achieve that suspicion of safety? Here, laser security system provides us with a solution and for this reason more and more people are installing them in order to stay safe and secure. Laser Security alarm is a device used for security purposes. It has a wide application in fields of security and defense starting from the security of a simple house hold material to a very high valued material of an organization. They once used to be very expensive solutions for security needs. Owing to cost cutting and fast technological advancements, this form of security system is becoming more affordable.

In this project, we have designed Laser Light Security System Using Arduino with Alarm with the application of Laser Diode Module KY-008. The project idea revolves around creating a security system. Whenever any object will obstruct the LASER ray the buzzer alarm will start ringing. This project can be implemented anywhere, not only buildings or premises but many precious things like jewelry,

diamonds, precious antique items in the museum, etc many other things are also secured using such an invisible LASER beam. Many people secure their home, office, shops, warehouses, etc with the LASER beam security system.

1.2. LITERATURE REVIEW

The earliest security system comes from the early 1990's. They were very expansive at that time and hard to monitor an intrusion. Now the technology has developed very much more than the old days. Laser security system is also known as burglar alarm systems. In most common security system laser and light dependent resistor are used. This system is easy to construct and install. Now day's lots of advance security system such as PIR based security system, temperature detecting based security system, infrared security system, etc. has come into existence. Among them this system is single and effective too.

Circumstance has shown that most criminals are usually cut off by the help of the simple existence of an alarm security system in our homes hospitals, schools, organization, and industries. Criminals usually invade far more defenseless constructions compared to those guarded by security alarm systems. The improvement of the security alarm systems started with the creation of man. To give threatening information, human being implements a form of a signal, shout, and sound. It was then replaced with the help of the clapping of hands and with the instilling of signals to notify society or to blowout a certain message during the early periods of some African society [2].

The earliest electronic fire, security alarm system was developed by a man named William .F. Channing. Late on an electrical electronics engineer, Mr. Moses G. Farmer invented the construction. This alarm system uses automatic indicator boxes to label the position of the outbreak fire and was first lunch in Boston,

United States of America. The development of this alarm system by Dr. William was then followed by the improvement of various stylish and difficult fire and intruder security alarm system technology that is so many to deliberate [4].

Researchers from Malaysia have developed a multilevel home security system which consists of different sensor nodes as input elements while the output elements respond to the signals received from input elements. The sensor nodes include an alarm, presence detecting circuit and a camera [5]

Researchers from China have developed a system using WSN and GSM technology. It can detect theft, fire, leaking of gas and send message to the owner. The hardware consists of single chip C5081F310, wireless receiving and sending chip CC1100 and Simens TC35 GSM module [6].

2. PROPOSED SYSTEM

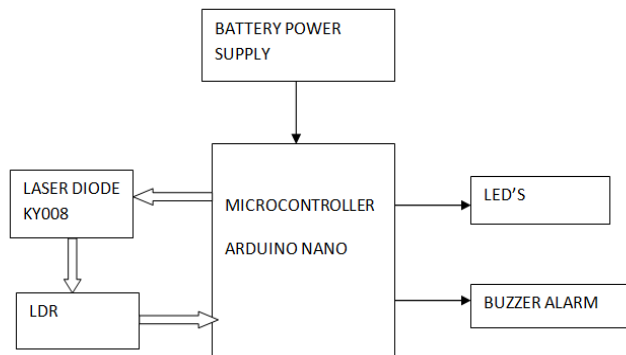

Fig 1: Block Diagram of System

In this, we present the theory on laser security system. In this proposed block diagram consist of several blocks like laser module, LDR, buzzer Alarm is connected to our controller. There are three essential components to a laser security system: a laser, a arduino and LDR module. The laser is a concentrated light source that puts out a straight line, pencil beam, of light of a single color. The LDR is sensitive to light. The LDR is connected to the Arduino NANO. When the laser bean is interrupted and can't reach the LDR, its voltage output changes, and the circuit senses the change and puts out a warning signal and then the buzzer starts alert signals. The project basically works on the principle of interruption. If by any means the laser light is interrupted the alarm will start unless it is reset with the pushbutton. The laser is a concentrated light source that puts out a straight beam of light of a single color.

The LDR is sensitive to light and puts out a voltage when the laser light hits it. When the laser beam is interrupted and can't reach LDR, its voltage output changes, and eventually the alarm will ring.

A. Arduino Nano:

The Arduino Nano is a small, complete, and breadboard-friendly board based on the ATmega328 (Arduino Nano 3.x). It has more or less the same functionality of the Arduino Duemilanove, but in a different package. It lacks only a DC power jack, and works with a Mini-B USB cable instead of a standard one. The Arduino Nano can be powered via the Mini-B USB connection, 6-20V unregulated external power supply (pin 30), or 5V regulated external power supply (pin 27). The power source is automatically selected to the highest voltage source. The ATmega328 has 32 KB, (also

with 2 KB used for the boot loader. The ATmega328 has 2 KB of SRAM and 1 KB of EEPROM. Each of the 14 digital pins on the Nano can be used as an input or output, using pin Mode(), digital Write(), and digital Read() functions.



Fig -2: Arduino Nano

B. Laser Diode Module (KY-008):

Laser Transmitter module KY-008 for Arduino emits a dot-shaped, red laser beam. The KY-008 Laser transmitter module consists of a 650nm red laser diode head and a resistor. Handle with caution; do not look directly into the laser head. The specification of Laser Transmitter Module KY-008 is as follows:

- Operating Voltage – 5V
- Output Power – 5mW
- Wavelength – 650nm
- Operating Current – less than 40mA
- Working Temperature – -10°C ~ 40°C [14°F to 104°F]
- Dimensions – 18.5mm x 15mm [0.728in x 0.591in]



Fig -3: Laser Diode KY008

C. LDR:

A photo resistor or light dependent resistor is an electronic component that is sensitive to light. When light falls upon it, then the resistance changes. Values of the resistance of the LDR may change over many orders of magnitude the value of the resistance falling as the level of light increases. Although

other electronic components such as photodiodes or photo-transistor can also be used, LDRs or photo-resistors are a particularly convenient to use in many electronic circuit designs. They provide large change in resistance for changes in light level.

The most common type of LDR has a resistance that falls with an increase in the light intensity falling upon the device (as shown in the image above). The resistance of an LDR may typically have the following resistances: Daylight= 5000Ω ,Dark= 20000000Ω



Fig -4: LDR

D. Buzzer:

This buzzer can be used by simply powering it using a DC power supply ranging from 4V to 9V. A simple 9V battery can also be used, but it is recommended to use a regulated +5V or +6V DC supply. The buzzer is normally associated with a switching circuit to turn ON or turn OFF the buzzer at required time and require interval. This buzzer can be used by simply powering it using a DC power supply ranging from 4V to 9V. A simple 9V battery can also be used, but it is recommended to use a regulated +5V or +6V DC supply. The buzzer is normally associated with a switching circuit to turn ON or turn OFF the buzzer at required time and require interval.



Fig -5: PIZOELECTRIC BUZZER

D. LEDS:

A light-emitting diode (*LED*) is a semiconductor light source that emits light when current flows through it. Electrons in the semiconductor recombine with electron holes, releasing

energy in the form of photons. Recent developments have produced high-output white light *LEDs* suitable for room and outdoor area lighting.



Fig -5: LEDS

2. CONCLUSIONS:

Laser security system provides us the security against any crime, theft in our day to day life and so people are installing them in order to stay safe, secure and Sound. Various electronic securities can be used at home and other important working place for security and safety purpose.it is great opportunity and source of saving man power contributing no wastage of electricity. The “Laser Security System” is an important helping system. Using this system robbery, theft and crime can be avoided to large extent. Avoiding thieves result in the safety of our financial assets and thereby this system provides us protection against all. The laser and LDR System are highly sensitive with a great range of working. The system sense the light emitted by the laser falling over the LDR connected with the circuit. Whenever the beam of light is interrupted by any means, it triggers the alarm or siren. This highly reactive approach has low computational requirement, therefore it is well suited to surveillance, industrial application and smart environments.

REFERENCES

[1] Olarewaju .I. K, Ayodele, O. E, Michael. F. O, Alaba. E. S, Abiodun. R. O, 2017. “Design and Construction of an Automatic Home Security System Based on GSM Technology and Embedded Microcontroller Unit”, American Journal of Electrical and Computer Engineering, Vol. 1, No. 1, pp. 25-32, Doi: 10.11648/j.ajece.20170101.14

[2] Zungeru. A. M, Kolo. J. G, Olumide. I, September 2012. “A Simple and Reliable Touch Sensitive Security System”, International Journal of Network Security & Its Applications, ISSN 0975-2307, Volume: 4; Issue: 5; pp. 149-165, DOI: 10.5121/ijnsa.2012.4512

[3] British Security Industry Association (BSIA), “Journal on security system section strategy for intruder alarm system”, Page 1-3, April 2005. Accessed at <https://www.thenbs.com/PublicationIndex/documents?Pub=BSIA>

[4] "History of Security Alarms",
http://www.icee.org/organization/history_center/fire_alarm.html

[5] Mohd. Saifuzzaman, Ashraf Hossain Khan, Nazmun Nessa Moon, Fernaz Narin Nur, "Smart Security for an Organization based on IoT", International Journal of Computer Applications Volume 165 -No.10, May 2017

[6] Suresh.S, J.Bhavaya, S.Sakshi, K.Varun and G.Debarshi, "Home Monitoring and Security System", ICT in Business Industry & Government (ICTBIG