

# FIND MISSING PERSON USING ARTIFICIAL INTELLIGENCE

Sanskar Pawar<sup>1</sup>, Lalit Bhadane<sup>2</sup>, Amanullah Shaikh<sup>3</sup>, Atharv Kumbhejkar<sup>4</sup>, Swati Jakkan<sup>5</sup>

<sup>1-4</sup>Department of Computer Engineering, JSPM Narhe Technical Campus, Pune, Maharashtra, India

<sup>5</sup>Assistant professor, Department of Computer Engineering, JSPM Narhe Technical Campus, Maharashtra, India

\*\*\*

**Abstract** - Face recognition is a biometric-based technology that mathematically maps a particular person's or individual's facial features and stores all that data as a face print. By using this technique, the information of the face of a person is saved mathematically or in the format of graphs in the database, which is used for detecting that particular face. Face recognition model in our system will find a match of that person in the database. If a match is found, it will be notified to the police and the guardian of that person.

In this paper we will use the ideas of the AWS facial recognition algorithm which is based on Artificial Intelligence (AI) and will detect faces with the maximum accuracies to find the missing person.

**Key Words:** Amazon Web Services (AWS) Face recognition, Amazon S3 bucket, AWS Lambda indexer, Face Recognition, missing person, Rekognition.

## 1. INTRODUCTION

In the world, a countless number of people are missing every day which includes kids, teens, mentally challenged, old-aged people with Alzheimer's, etc. Most of them remain untraced. This paper proposes a system that would help the police and the public by accelerating the process of searching using face recognition.

Face recognition technique can be used for many things and finding the missing person is a biggest advantage for any face recognition technique. To make the task of finding the missing person easier we are planning to make an application which will be accessed by some volunteers through which we can find missing person in short span of time. This will make the work of police to find a particular person easier.

Meanwhile, there is a need of automation for automating the task of finding the particular person by recognizing particular image and comparing that image with other image in order to check whether both images has same characteristics or not. By doing this we will come to know whether the missing person in the image clicked from particular location is correct or not, and if it is correct then police can start their next steps to find the person from that area.

In our application there will be the feature of saving all the data of the missing person so that system can detect that image data and trace the missing person.

## 1.2 Motivation

Physically it takes huge time, as it is lengthy procedure for finding missing person as it increases time to launch an FIR in police station. Also during handy process workforce for searching missed person is not so great and due to this half of the cases remain mysterious.

An alarming fact about India's missing children is that 296 children go missing every day on average. And every month, that is a disturbing number of 9,019, half of them remain untraceable.

Shockingly, when India was dealing with the Covid-19 pandemic in 2020, the total number of children missing across India was 1,08,234, according to the National Crime Records Bureau data. 33,456 girls were reported missing and 15,410 boys were missing, and 43,661 of them remained untraceable till the end of the year.

However, the statistics are indicative of the absence of a national Missing Children's repository. "There are no budgets earmarked for tracking missing people," said an official source.

## 2. EXISTING SYSTEM

When we went through the website, we immediately understood the issue. The process to submit pictures of a child (you find suspicious) in your area is tricky and not anonymous.

People who employ these children are powerful people nobody wants to mess with; this is why the user prefers anonymous submission.

The initiative wasn't using the power of machine learning. Since it is happening on a large scale, there should be an automated solution.

As shown in below image we can access the all information of missing person under the tab of 'Photographs of Missing persons' as well as we can access the photographs of recovered children under the tab of 'Photographs of Recovered children.



By clicking on 'Photographs of Missing children' we can get all information as well as photographs of missing persons as shown below:

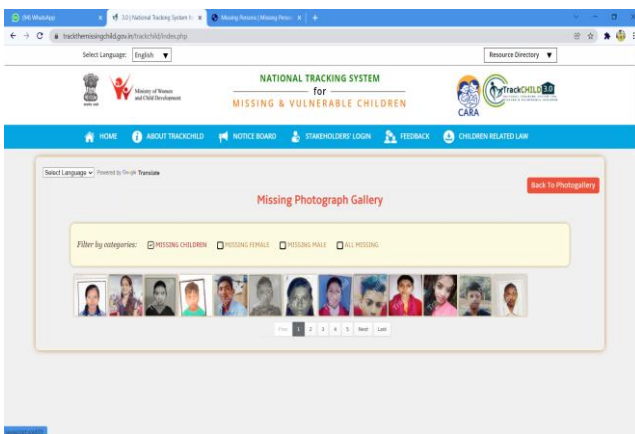

They have published it for peoples that really want to help police for finding the missing persons. But if people who employ these children as child labors or any dangerous purpose got that particular person's information on the website then those people will definitely make things difficult for that person. In this way the information present on website can be misused by such peoples.

### 3. LITERATURE SURVEY

We did lot of survey and summed up following regarding literature survey so firstly, S. AYYAPPAN and his fellow mates from IFET College of Engineering have a presented a paper which deals with a similar problem statement and objective. The system proposed by them makes use of Deep Learning based Facial Feature Extraction and matching with stacked convolutional auto encoder (SCAE). The images of missing Persons are stored in a database. Faces are detected from those images, and a Convolutional Neural Network learns features. These learned features were utilized for training a multi-class SVM classifier. They used this method to identify and label the kid correctly. The main difference between their work and ours is that we are going to create a dataset of lost persons with the help of people who want to

contribute to society (voluntary work). Also we are not going to disclose the details of lost person with the public. And their system involves complex algorithms which make the process of extraction and classification slower [1].

Previously, Shefali Patil and his fellow mates from SNDT Women's University, Juhu, Mumbai have a presented a paper which deals with a similar problem statement and objective. The system proposed by them uses KNN Algorithm which makes use of  $136 * 3$  data points to recognize Face. The main disadvantage of using the KNN method is its accuracy 71.28% and also it does not address cross-age face recognition. The main difference between their work and ours is that here we are going to create a dataset using a mobile application with voluntary work of people. we are going to use AWS facial reorganization which has cross-age face recognition. Also, our dataset is going to be stored in the cloud database.[2]

In 2020, Sarthak Babbar, Navroz Dewan, Kartik Shangle and his fellow mates from Jaypee Institute of Information Technology, Noida, India team gave out a paper in which gave us very clear idea about how Amazon Web Services (AWS) Recognition works and it compares AWS recognition with other algorithms and systems like CDAC-VS, CNN. So this paper helped us in identifying the algorithm that we are going to use in our project e.g Amazon Web Services (AWS) Recognition Our faces will change with time as our age increases, while the pictures in our dataset remain the same. We intend to study the accuracy of Residual Network (ResNet) for the purpose of cross-age face recognition. The performance is compared to cross-age reference coding (CARC), Amazon Web Services (AWS) Recognition and other techniques on the various data set viz., cross-age celebrity dataset (CACD) and a verification subset CACD-VS. ResNet and AWS Recognition achieved 98.40% and 99.45% accuracy, respectively on the CACD-VS dataset.[3]

In August 2016, Rohit Satle and his team presented a paper which addresses the face recognition system built by using Principal Component Analysis(PCA) method. The two main drawbacks of applying the PCA method are that computational complexity is high, and it can only process faces with similar facial expressions. The main difference between their project and ours is that our project can identify the particular person even if different facial expressions are there in both images. Our system will also detect particular person's 2 different images, one image with moustache and another image with no moustache. We will make use of AI for recognition of images which will definitely increases our accuracy level.[4]

According to the research paper presented by Birari Hetal and her fellow mates from Late G.N. Sapkal College of Engineering, who had also deal with the similar problem statement and objective. They have made the Android application for making the task of missing person easier. The Android Application proposed by them makes use of SWF-

SIFT algorithm for comparing two images. In their application, only Admin and some trusted people like police, etc., can update the data set continuously. The main difference between their system and our system is that we are going to allow application users for uploading images (update data sets) of suspicious peoples like child beggars whom they think that they are missing. Although the images uploaded by that particular user is not viewed on our application to anyone except Police Department. So we are trying to keep that data in safe hands. [5]

In August 2014, Swarna Bai Arniker and K.Sita Rama Rao his team from Research Centre Imarat, Hyderabad presented a paper which gives use insights of RFID Based Missing Person Identification System This RFID reading equipment may be maintained at all police stations and public gatherings in the future. This has applications for recognizing lost children, physically challenged children, senior citizens and handing them over to their guardians. The prerequisite is that the person must physically put on the RFID tag. So it has limitation of carrying that RFID Chip which will track the particular person.[6]

#### 4. PROPOSED SYSTEM

The proposed system makes use of various methods for finding missing people.

The system structure is presented in Fig.1.

Overall Structure of Proposed System To prevail over the drawbacks of previous systems. We are building a system that existing systems were not having. We plan to add concepts regarding how the interface ought for adding new complaints and how to register the new case.

The face recognition model in our system will try to find a match in the database with the help of AWS rekognition. It is performed by comparing the face encodings of the uploaded image to the face encodings of the images in the database. If a match is found, it will be notified to the police and the people related to that person along with the location of where the person is found.

The proposed system contains the following Modules:

##### Volunteer Module:

- Volunteer Registration/ Login (Using E-mail ID, Mobile Number, Password, etc.)
- Filling in the details such as the location, age of the suspected missing person and then upload the image of a suspected missing person.

##### Police / Authority Module:

- Police/ Authority Login (Using Email ID, Mobile Number, Password)

- Registering Complaint about the missing person.
- Uploading the image and other details of the missing person (eg. Name, Age, Sex, Living Location).
- Search the uploaded image with a stored database, if found then give result as match found and also send an email to the user and if not then store as a new entry.
- Inform via e-mail to the respective authority when a match is found with AWS Rekognition. (Ref. Fig. 2)

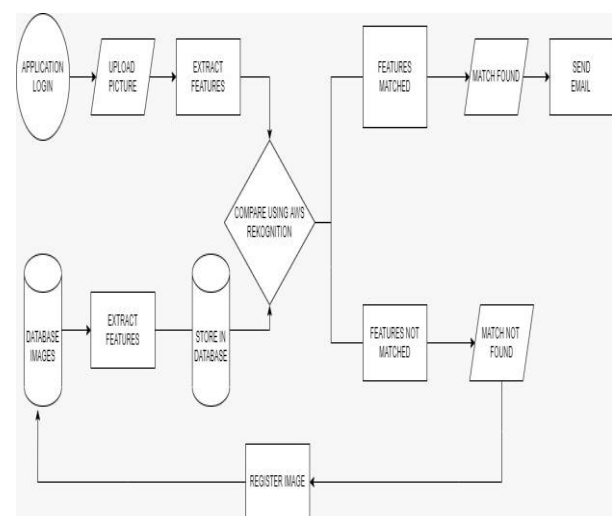

Fig -1: Structure of System

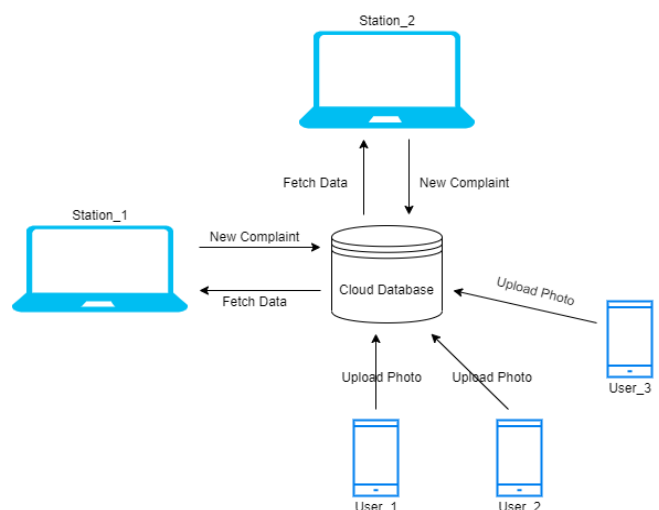

Fig -2: Architecture

**4.1 TECHNICAL PROPOSITION:**

This is the high-level system Design of our proof of concept which uses AWS Rekognition for facial recognition. The picture of a missing person will be uploaded to the application with the help of AWS Rekognition.

AWS Rekognition will identify a face in that picture and then that face ID along with the missing details will be stored in the S3 bucket. Then the search of the user's human face will happen by uploading an image. If this new image has a face already available within the database, then AWS recognition will trigger an SNS notification to an email id. That's the high-level design, the first business process by using volunteers to capture an image of a human being.

Then we will store that image in the application with the help of AWS Rekognition along with some other details of the human being. Those details will be stored in the S3 bucket. AWS Rekognition will analyze the image uploaded. It will return a unique face id which is always unique for a given face and then that face id will be used as a unique key to store the related details of the missing person in DynamoDB and once we want to search the face, we will use an existing Image.

Using the search functionality, that new face image will be uploaded to the application with AWS recognition. If a face match is found, an SNS notification will be triggered and an email will be sent to the respective authority's email id. (Ref Fig.3)

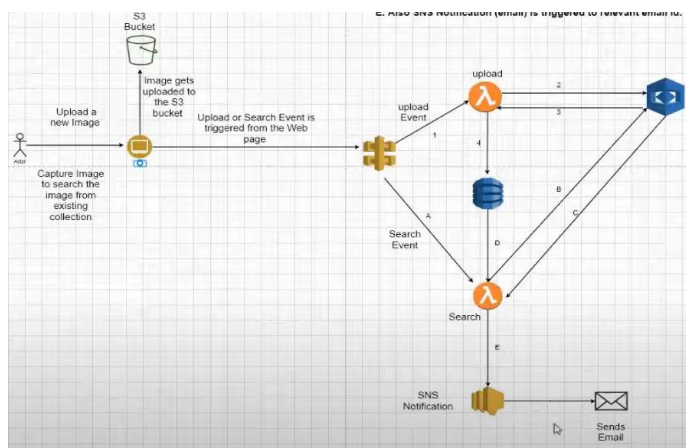

**Fig -3:** Flow

We plan to add two events:

Upload Image Event:

1. Use an existing image and upload the image to the S3 bucket.
2. Once the image is uploaded to the S3 bucket, the upload lambda is invoked.

3. Upload lambda stores the image in Rekognition under a collection and faceld is returned.
4. Lambda Stores the faceld and other details in DynamoDB S3 Bucket.(Ref-4)

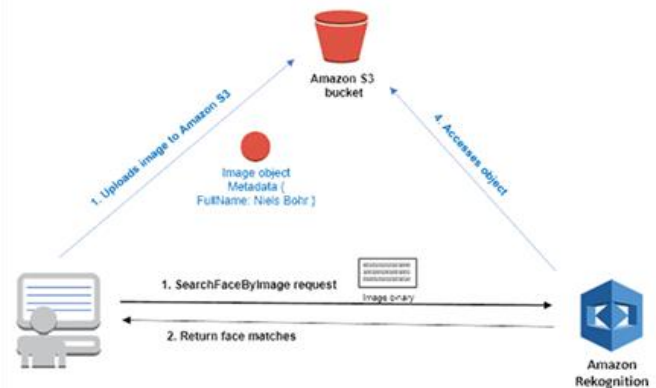

**Fig -4.** Working of AWS Rekognition

Search Image Event:

1. Using an Existing image for Search Event an image is uploaded to the S3 bucket.
2. Once the image is uploaded to the S3 bucket, the Search lambda is invoked and the search event is triggered in Rekognition.
3. Image is Searched in Rekognition using searchFaces ByImage API and faceld is returned in case of a successful match.
4. Lambda uses the faceld to fetch the other related details (e.g. name, age, sex, address) from the DynamoDB.

Also, SNS Notification (email) is triggered to the relevant email id.

**5. CONCLUSIONS**

Image recognition with the use of one-shot learning has become very powerful. This technology when put into good use, can be beneficial. It can even be used in Hotels, Hospitals, etc., to find criminals instantly.

Process of identifying the missing people is fastened. Our system replaces the manual scanning process through the databases for each picture to check the match, by an efficient face recognition method which finishes the work in no time.

In the future, we are planning to extend this system further by connecting our system to public cameras and detect faces real-time. The frames will be continuously sent by the public cameras to our system where our system will be continually monitoring the frames. When a lost person is identified in

any of the frames, It will notify the concerned authorities, the method that finishes the work in no time.

## REFERENCES

- [1] S. Ayyappan and S. Matilda, "Criminals and missing children identification using face recognition and web scrapping" IEEE ICSCAN 2020.
- [2] Shefali patil, Pratiksha Gaikar, Divya Kare, sanjay Pawar, "Find missing person using AI", International journal of Progressive Research in Science and Engineering, Vol. 2, No. 6, June 2021.
- [3] Sarthak Babbar, Navroz Dewan, Kartik Shangle, Sudhanshu Kulshreshtra, Sanjeev Patel, "Cross Age Face recognition using Deep Residual Networks ". IEEE 2019 Fifth International Conference on Image Information Processing (ICIIP).
- [4] Bharath Darshan Balar, D S kavya, Chandana M, Anush E, Vishwanath R Hullipalled, "Efficient Face recognition system for identifying lost people", International Journal of engineering and standard technology (IJEAT), ISSN:2249-8958, Volume-8, Issue-5 S, May 2019.
- [5] Birari Hetal, Sanyashiv Rakesh, Porje Rohan, Salwe Harish," Android Based Application-Missing Person Finder", IRE Journals, Volume1 Issue 12, ISSN: 2456-8880
- [6] Swarna Bai Arnikar, G. Kalyani, D. Meena, M. Lalitha, K. Shirisha, Seetasaikiran, "RFID based missing person identification system", IEEE 2014 International Conference on Informatics, Electronics & Vision (ICIEV).
- [7] Sayan Deb Sarkar and Ajitha Shenoy, "Face Recognition using Artificial Neural Network and Feature Extraction", IEEE 2020 IEEE 7<sup>th</sup> International Conference on Signal Processing and Integrated Networks.
- [8] <https://trackthemissingchild.gov.in/trackchild/index.php> National government tracking system for missing & vulnerable children's.