

IMPLEMENTING A SUSTAINABLE SMART CITY MODEL OF A UNIVERSITY CAMPUS

Derya Betül UNSAL^{1,2}

¹Sivas Cumhuriyet University, Department of Energy Science and Technology Engineering, Sivas, Türkiye.

²Sivas Cumhuriyet University, Renewable Energy Research Center (CUYEM), Sivas, Türkiye.

Abstract - Recently, in the world, the technology is developing and the use of energy is increasing day by day. This situation also increases the rate of environmental destruction of energy resources. The gradual decrease in fossil resource reserves, causing irreversible damage to humans and nature, has led to the search for alternative energy sources. Within the scope of sustainability, renewable energy sources have many advantages. In order to utilize this advantage, environmentally sustainable systems can be designed using smart technologies. The first step in transforming the existing urban functioning into a smart city model is to create the necessary technological infrastructure based on IOT (Internet of Things), to develop plans, strategies and models within this framework, and to evaluate the obtained data and disseminate the appropriate ones. In this study; By giving general information about energy resources and smart cities, the positive and negative aspects of renewable energy resources, as well as the requirements of sustainability in energy and environment are examined, designed and concluded with smart campus.

Key Words: Renewable Energy Sources, Sustainability, Smart Campus Design, Smart Cities.

1.INTRODUCTION

In recent years, increasing energy use with the development of technology has revealed the possibility of depletion of energy resources. This has been a force that has encouraged researchers to seek alternative energy sources. For this very reason, energy and the environment have become subjects that have been closely examined and interrelated with an increasing rate in the world in recent years. The environmental damage that will occur as a result of not using alternative energy sources with the right technologies can lead to irreversible problems over time. From this point of view, the concepts of environment and energy should not be evaluated independently of each other.

Sustainability, on the other hand, is defined by the United Nations (UN) as "The practice of maintaining world productivity processes indefinitely by replacing the resources used with equal or more valuable resources without destroying or endangering natural systems" [1].

When the developments about energy and environment are considered in terms of the use of energy resources, the use of fossil fuels causes many negative effects on the environment, such as high greenhouse gas production, soil pollution,

pollution of ground and surface waters. However, it is observed that the international fossil fuel reserves of the whole world are also decreasing and some studies mention that there will be a significant problem in annual oil availability for 2050. Due to these facts, the necessity of developing fuels obtained from new, alternative and especially sustainable sources arises.

Energy resources can be classified according to their purpose of use and production method. Energy resources, which are considered as self-renewing or non-renewable, can be used with various technologies for different purposes. Alternative energy sources to fossil fuels, which will be examined in detail in the chapter, have the potential to change the structure of technology and production activities all over the world. Thanks to alternative energy sources, which have solutions that include the use of materials considered as waste in energy production and use processes, not only the environment is protected while energy is consumed, but also sustainable development can be supported. However, if the right technologies are not used, the environment can be harmed when using alternative energy sources. For this reason, the relationship between energy, environment and sustainability should be well understood.

The aim of this study is to provide information to researchers who aim to carry out an analysis on similar topics: the development of alternative energy sources, their environmental advantages, disadvantages and a review of the latest technology used in the right application, and attention to smart systems that combine environmental protection energy production and consumption, the goals and processes in the development of these systems.

The concept of smart city was used for the first time in 1994. In the years when the concept emerged, it was observed that the number of studies on this subject was very few and generally focused on research on the importance of information and communication technologies in the establishment of modern infrastructures in cities [3].

The California Institute is recognized as one of the first institutions to focus on how communities can become smart and how a city can be designed to apply information technologies [4].

In 2010, the European Union's use of the concept of "smart" to characterize sustainability projects and actions in urban areas led to a significant increase in the number of studies

and different aspects of the city were added to the studies on the subject [3].

Some defined the smart city as a more efficient and elegant urban environment than the messy urban environments we live in today, while another group defined it as a market for urban governance and firms selling the sensors, controllers and servers that enable the smart system to be installed. In other words, it has been described as an urban form that provides capital accumulation. However, there are studies that define a smart city as a city that uses publicly available data to solve problems such as waste management and traffic control [5].

Although there is no clear consensus on the definition of the smart city, it is generally tried to be defined through two basic approaches. The definitions made within the scope of the first approach emphasize the use of technologies to facilitate the coordination of fragmented urban subsystems such as energy, water, mobility and the built environment. In this approach, it is assumed that the improvement of subsystems, in other words, making them “smart” is associated with new employment opportunities, wealth creation and economic growth. The second approach has a futuristic perspective. In this approach, it is assumed that the experience with smart cities will reveal a new reality. Another problem that arises outside the definition of the concept of smart city is experienced in the answers given to the question of what makes the city smart.

There are two different approaches in this regard;

The first one is that “urban spaces are structures consisting of both software and hardware (everyware)”. In other words, equipping cities with information technologies is considered sufficient to create a smart city.

The other approach underlines the fact that cities consist of economy and administration, and emphasizes the human figure. He states that innovation, creativity and entrepreneurship abilities of smart people living in cities are effective in transforming cities rather than information technologies [4-6].

When evaluated within these scopes, university campuses and university students living in the campus are in the smart society class in terms of their ability to both use IoT technology and adapt to innovations. To adapting the smart city model to smart campuses, this idea was acted upon. In this study, when the smart campus was being designed, a campus model was created in the Matlab, and the requirements of the smart city concept were discussed which is shown in Figure 1 and calculated on this model [7].

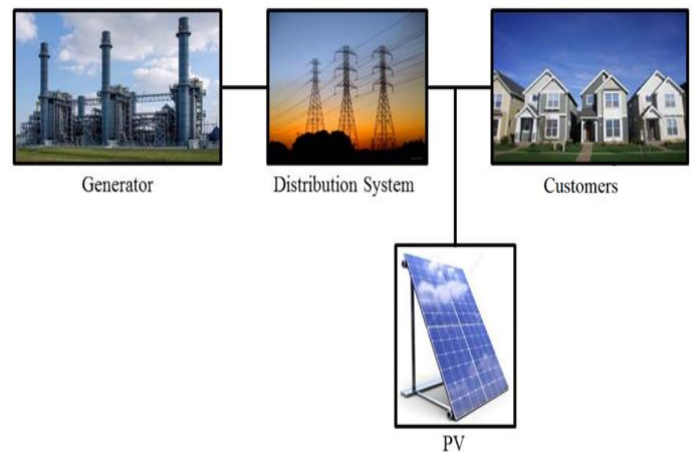

Fig -1: General Infrastructure Design of Smart Campus.

2. MODELLING SMART CAMPUS WITH SMART CITY OBJECT

It is known that with the development of technology, people's welfare level and their harmful effects on the environment increase in direct proportion. Humans are a part of the natural environment, and this concept, also called human ecology, expands the concept of sustainability with humans in the focus of development. The need for air, water, and shelter, which are the ecological foundations of sustainable development, also form the foundations of human ecology [4]. Sustainable development can be strengthened together with people, with investments to be made in the environmental ecosystem. [5].

Environmental sustainability is about how the environment can remain natural and productive while maintaining diversity. The state of the air, soil, water and climate is of particular concern when energy-producing resources are taken from nature. The IPCC 5th Assessment Report, which covers these issues, summarizes the current information on scientific, technical and socio-economic information related to climate change and the change of nature, and lists the options for reducing the harmful effects of the environment and living in harmony [6].

It is necessary for people to understand that they are a part of environmental sustainability and to be encouraged to act individually in this regard. As a result of the use of energy resources, if each individual can be beneficial to his environment, the concept of sustainable society will be reached.

There are programs financially supported by Horizon 2020, a product of European environmental research and innovation policy, which aims to evaluate the economy and society as a whole and thereby define and implement a transformative agenda [7, 8]. It is necessary to focus on the development of a sustainable society; to design smart, flexible and adaptive systems and to integrate these systems into human life [9, 10].

Thanks to these systems, the society will be able to develop, energy use and welfare will increase, while environmental sustainability will be ensured.

When it is desired to deal with the issue of environmental sustainability in terms of energy, it can be started by examining the definition of energy. Energy is defined as the capacity of a system to do work. In order for the system to do work and continue to work, it needs the use of energy source because it provides energy. These energy sources are divided into two as renewable and non-renewable. Non-renewable, exhaustible and unsustainable energy resources can be listed as Natural Gas, Petroleum, Coal. Renewable energy sources are; It is classified as Solar Energy, Wind Energy, Biomass Energy, Geothermal Energy, Hydroelectric Energy, Hydrogen Energy, Wave Energy and Nuclear Energy [9, 10]. However, it should be known that the use of every energy source is an intervention to nature and has an absolute effect.

While the side effects of obtaining energy from fossil fuels are more acceptable and known by the society, it would be wrong to think that all renewable energy sources are environmentally friendly. Renewable energy sources, which turn into environmentally friendly energy sources when the right technologies are used, may become more harmful than fossil sources when implemented with wrong practices. If the major points in the case of evaluating energy resources with regard to the destruction of the environment are examined;

In the use of fossil resources, harmful gases that arise due to the burning of coal, natural gas and oil accumulate in the atmosphere and accordingly cause side effects such as greenhouse gas emissions and climate change and global warming. It would be wrong to think that all renewable energy sources do not harm nature, although the damage to the environment is much less when compared to non-renewable, depleted, fossil sources. For example, if the environmental effects of hydraulic power plants, which are thought to cause the most damage to the environment among renewable energy sources, are examined, they can be listed as follows. The effects of hydraulic dams on the environment can be evaluated under three headings. Potential impacts during the construction phase, Potential impacts during the impoundment and operational phases, and Potential post-closure impacts [11].

Smart city applications enable to monitor the mobility in urban life, to ensure the safety of the city and its inhabitants, to analyze environmental factors and ecological applications and to strengthen the civil infrastructure in combinations of all these. On the other hand, smart cities increase quality living standards by making it easier for managers to monitor, understand, analyze and plan the city in order to improve the quality of life and efficiency of the city [4].

In the smart campus matlab model shown in Figure 2, PV was chosen as a renewable energy source and it was realized with a micro grid design in an IEEE 14 busbar system.

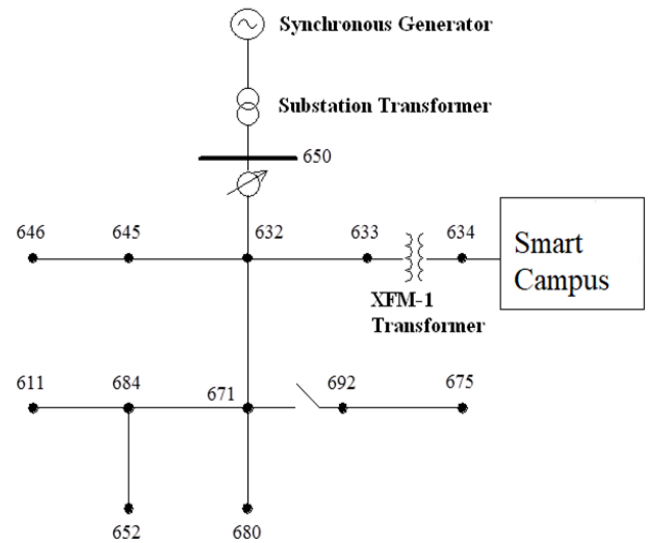

Fig -2: Designing Smart Campus Matlab Modelling.

After the application, there are environmental effects that can be explained as soil quality, erosion and land use, soil safety, seismicity and seismic risk, climate and greenhouse gas formation among the effects on the physical environment. Climatic effects occur due to the fact that the surface areas of the dam lakes are larger than the streams or rivers and the evaporation increases. In this way, the humidity in the air increases and the air movements change.

As a result of these, temperature, precipitation and wind events can go out of the standard. In this case, nature, vegetation, agricultural plants, aquatic terrestrial animal existence in the region enters into a sudden change, and adaptable species continue their lives. Blocking the rivers and turning them into dam lakes cause the evaporation of some of the water in the dam lake and the increase in the amount of salt and other minerals in the water. On the other hand, due to the decrease in the speed of water passing from the stream to the lake, the diffusion and oxygen uptake capacity decreases, the natural cleaning capacity decreases and the lake enters the eutrophication process. In addition, during the construction phase of dams; In particular, leaving the excavations in the stream or river beds indiscriminately, the long-term turbidity of the works below the water level, and the discharge of waste water to the stream bed without rest are the biggest dangers during the construction phase.

When the construction wastes are evaluated, it can be listed that the excavation, especially the excavation down the slopes, the destruction of the tree and forest flora, the impact of the material quarries and the transportation roads. The effects on the biological environment can be exemplified as Flora and vegetation, Terrestrial fauna, Aquatic fauna, Dissolution of air nitrogen at the level of supersaturating due to water falling from height and being lethal for fish. The effects on the socio-economic environment can be exemplified as the change in the value of the land causing

expropriation and resettlement, the change in infrastructure and transportation, the loss of cultural values as a result of the failure to protect the natural and historical assets in the region [11].

If the advantages of hydroelectric energy are examined; Like thermal and nuclear power plants, heated water is an important alternative energy source that does not cause air emissions, ash and radioactive waste. Nuclear and thermal power plants are an important alternative energy source that does not cause heated water, ash and radioactive waste. It can be concluded that thermal power plants are the most damaging energy source to the environment due to the carbon dioxide emissions they create and the effect of global warming.

However, when other renewable energy sources are examined, there are points that can be considered as minor effects. For example, Wind Farms have disadvantages such as the noise they cause and the effect of changing the migration path of birds. Although geothermal energy is an advantage over fossil fuels in that it generates energy with sulphur and nitrogen oxide emissions and almost zero waste, it requires reinjection due to the release of hydrogen sulphide and carbon dioxide derivative gases during the use of this source, which comes from the depths of the earth's crust, can be listed as its disadvantages. Like every energy source, if wrong technologies are used in the use of geothermal resources, it can lead to environmental pollution [12].

When evaluated in terms of environmental destruction, biomass and solar energy can be considered as the most environmentally friendly energy sources, but there are points to be considered for both energy sources. Biomass energy is defined as the type of energy obtained after burning or other processes of biomass wastes. Biomass has a great potential among alternative energy sources and has advantages such as being a source that can provide continuous energy, not intermittent like wind and sun, and being effective in reducing climate change and greenhouse gas emissions. The carbon cycle system existing in nature can remain in balance, as the CO₂ gas produced as a result of the combustion reaction is reabsorbed by the renewed vegetation after combustion. In this respect, biomass energy is considered an alternative and clean energy source. The easy storage of biomass energy is also one of its advantages [12].

Solar energy does not cause greenhouse gas emissions, on the contrary, if its use becomes widespread, it has the title of the cleanest resource among renewable energy sources, with its features such as playing an active role in reducing the CO₂ density and not generating waste. For this reason, it must be included in the smart campus design.

3. DISCUSSION AND CONCLUSIONS

When look at the relationship between energy and the environment, it is seen that the two issues are a whole and should be evaluated together. The solution to environmental problems arising from the use of non-renewable fossil resources is to prefer renewable, environmentally friendly energy resources. While the relationship between energy and environment continues to be discussed as the main problem of globalization, which has been continuing at an ever-increasing rate from the first human to the present, reducing energy use should also be presented as a solution when evaluated in terms of resource consumption. For example, the demand for energy can be reduced by the widespread use of smart automation systems. Intelligent systems can monitor and control themselves, thereby reducing energy use. In a broader context, with the Smart Building, Smart City and Smart Grid structure, the need for energy will decrease and therefore less energy resources will be consumed. There are temperature and humidity control in smart buildings, energy efficiency with the current and voltage values consumed for electrical appliances, and authentication applications at home and building entrances. It is accepted that smart cities consume less energy, contribute to human and energy capital in harmony with technology, and provide economic growth and high quality of life in the city with traditional and modern communication infrastructure. When evaluated in this context, examples from the world can be given to smart applications that will reduce energy resource consumption and contribute to the environment and sustainability. With the Internet of Things (IoT) Technology, many technologies based on smart cities are developed, thus preventing the use of unnecessary energy sources and increasing the use of renewable energy sources, contributing to environmental sustainability. For example, smart traffic lights in smart cities, where applications are made to integrate IoT technology into traffic lights, prevent people from losing time and energy, while free parking spaces and electric vehicle charging stations can be detected and drivers can be warned about where they can find a suitable place. In Smart City and Smart Building applications, this technology is also used to increase the safety of residents and increase incident response times [13].

If smart city examples from the world are given, cities such as London, Singapore, Tokyo, Hong Kong, Oslo, Amsterdam, Stockholm can be given. Although the smartest city in the world varies according to different years and classifications, Singapore is the most remarkable of the smart cities in the world in 2021 with its privileges and technological features. In addition to smart and connected traffic solutions to reduce the number of vehicles, it implements a strict policy limiting vehicle ownership, and the use of autonomous vehicles in the city is increasing day by day, and there is an application called Health City Novena, which is considered as one of the healthy society applications with the Society 5.0 target [13]. While the smart road in London can be

portrayed as a smart city with human interaction, Songdo and Masdar City in the United Arab Emirates can be thought of as two popular smart cities that are too technology-centric and do not have many human experience factors. Barcelona is cited as one of the successful examples of the balance between technology and society, which it initiated with the Smart City 3.0 strategy [13, 14].

In order to achieve the smart campus goal, we can look at how smart city initiatives are launched to achieve one or more of the goals of parking, smart healthcare, smart agriculture, smart transportation, smart government, smart energy [13-15]:

- It is aimed to optimize the use of public resources for Energy Efficiency and to provide a high level of citizen service.
- It is aimed to grow and develop the city by giving great importance to environmental impact for Environmental Sustainability.
- In order to increase mobility, it is aimed to reduce individual transportation vehicles and contribute to environmental sustainability by making it easier for citizens, employees and tourists in the society to move around the city by walking, cycling, vehicle or public transportation.
- In order to increase security and human peace, it is planned to increase public safety in daily life and private events, as well as to prepare for emergencies and disasters in the best way possible.
- It is aimed to attract businesses, investors, citizens and tourists to cities for economic growth.
- In order to increase the reputation of the city, it is aimed to continuously improve the image and reputation of the smart city.

Regardless of their main goals, successful smart city projects will bring cities closer to their ultimate goal of improving the level of "Liveability" by increasing the quality of life and well-being offered to people. In order to increase this level, different architectural strategies have also been proposed by Hans Neuber to design smart cities, the focus of which is technologies for rehabilitating city centers for those living on an individual scale. The work of the Neubert research team has uncovered the elements needed to integrate technology with city government in a way that respects human rights, civic nature and the public's pocket. According to the goals of the research team advocating that smart cities should be humanized [13-15]:

- With the application of smart parking and smart traffic signal technologies, which include smart transportation targets, reducing a citizen's commute time of 15-30 minutes a day will increase the welfare level of the society,

- To reduce the impact of diseases by 8-15% as a result of early diagnosis, diagnosis and treatment of diseases by using remote data sensing technologies in order to improve health,
- Reducing the crime rate by 30-40% with strategies using real-time crime mapping and prediction algorithms to increase city security,

- With the help of Smart Building applications and automation systems, it is aimed to reduce emissions by 10-15% and to contribute to environmental sustainability by using variable electricity pricing.

Neubert said, "Smart city technologies, when applied correctly, can provide a healthy platform for a two-way dialogue between the human citizen and the city. Architects and engineers are in a unique position to demonstrate how this can work in practice on a limited scale." He summarizes the situation by saying, and draws attention to the need for multidisciplinary studies in order to apply smart technologies to human life and to ensure sustainability in the environment and energy [15].

As a result, it can be said that the primary goal is to raise individuals with Environmental and Energy Consciousness. In order to realize this situation, it is necessary to start the necessary applications for the smart society as soon as possible. Smart technologies that will be developed with the new generation should be structured in the focus of Energy and Environment, and investments that will be used as energy sources in the future should be focused on sustainability. Since most of the renewable energy types produced cannot be stored, investments should be made in harmony with the demand, practices based on domestic energy resources and aiming to keep foreign dependency at a minimum level should be implemented. In order to meet the energy in the most accurate and safe way, Smart City and Smart Society targets should be acted upon. In order to ensure sustainability in the environment and energy, it is a vital necessity to have the awareness that it is possible to protect nature while increasing human welfare with technology.

REFERENCES

- [1] Lynn R. Kahle, Eda Gurel-Atay, Eds (2014). "Communicating Sustainability for the Green Economy", New York: M.E. Sharpe. ISBN 978-0-7656-3680-5.
- [2] White, F; Stallones, L; Last, JM. (2013). "Global Public Health: Ecological Foundations", Oxford University Press. ISBN 978-0-19-975190-7.
- [3] Dameri, R.P., Cocchia, A. (2013). "Smart City and Digital City: Twenty Years of Terminology Evolution", X Conference of the Italian Chapter of AIS, ITAIS, Università Commerciale Luigi Bocconi, Milan (Italy), 1-8.

- [4] Kuhlman, T., Farrington, J. (2010). "What is Sustainability?", *Sustainability*, 2, 3436-3448.
- [5] Glasmeier, A., Christopherson, S. (2015). "Thinking about smart cities, *Cambridge Journal of Regions, Economy and Society*, 8: 3-12.
- [6] IPCC Fifth Assessment Report (2014). "Climate Change 2014: Impacts, Adaptation and Vulnerability". Geneva (Switzerland): IPCC. Access: 07.08.2021
- [7] Unsal D.B et al. Investigation of LV Networks with EVs under High Penetration of PV Generation, IATS 2017, Oct 2017.
- [8] Fawcett, William; Hughes, Martin; Krieg, Hannes; Albrecht, Stefan; Vennström, Anders (2012). "Flexible strategies for long-term sustainability under uncertainty". *Building Research*. 40 (5). ss. 545-557. doi:10.1080/09613218.2012.702565.
- [9] Zhang, S.X.; V. Babovic (2012). "A real options approach to the design and architecture of water supply systems using innovative water technologies under uncertainty". *Journal of Hydroinformatics*.
- [10] Daly, H. E. *Economics, Ecology, Ethics: Essays toward a Steady-State Economy*. Hardin, G. "The tragedy of the commons". New York and San Francisco: W. H. Freeman and Company. ss. 100-114.
- [11] Unsal, D.B.; Ustun, T.S.; Hussain, S.M.S.; Onen, A. Enhancing Cybersecurity in Smart Grids: False Data Injection and Its Mitigation. *Energies* 2021, 14, 2657. <https://doi.org/10.3390/en14092657>.
- [12] Armstead H. Christopher H., *Geothermal Energy: Its Past- Present- and Future Contributions to the Energy Needs of Man*, ISBN 10: 0470263377, Publisher: E & FN Spon, 1978.
- [13] Maysoun I., Carl A. El-Zaart A. "Paving The Way to Smart Sustainable Cities: Transformation Models and Challenges", *JISTEM*, Vol. 12, No. 3, Sept/Dec., 2015 pp. 559-576 ISSN online: 1807-1775 DOI: 10.4301/S1807-17752015000300004
- [14] <https://www.forbes.com/sites/bernardmarr/2020/07/02/the-smart-cities-of-the-future-5-ways-technology-is-transforming-our-cities/#4ab178e973f8>, Access: 03.08.2021.
- [15] <https://www.newsweek.com/momentum-awards-worlds-smartest-cities>, Access: 03.08.2021.