

COMPARATIVE ASSESSMENT OF FLAT SLAB WITH SHEAR WALL AND BRACING SYSTEM FOR DIFFERENT BUILDING HEIGHTS

Ms. Naik Ashwini Shankarrao¹, Dr. P.B. Ullagaddi²

¹M. Tech Student, Department of Civil Engineering, Shri Guru Gobind Singhji Institute of Engineering and Technology, Nanded, Maharashtra, India-431606

²Head and Professor, Department of Civil Engineering, Shri Guru Gobind Singhji Institute of Engineering and Technology, Nanded, Maharashtra, India-431606

Abstract- Earthquake is an herbal disaster; it creates sturdy floor actions that affect the structure. Small or vulnerable actions which could or might not be perceptible to humans. Shear partitions and bracings are set up to enhance the lateral stiffness, ductility and minimum lateral displacement, and protection of the structure. Bracing structures and shear partitions are most normally implemented in medium to tall homes to offer the rigidity, strength, and power dissipation required to face up to masses from earthquakes and wind.

In this work, two main factors were considered, namely with shear walls and bracings for the ceiling structure. The Flat slab structure is modelled with the ETABS software and analysis for Response Spectrum analysis according to 1893: 2002. The Project work is carried out for (G+8), (G+10), and (G+12) stories of structure and the analysis for 12 different models, Flat slab with shear partitions and Bracing System.

From assessment various parameters, the Flat slab with shear Partition effects with the values of Story Displacement and Drift is decreased and the values of Story Stiffness and Shear is better than flat slab with the bracing system. It can be concluded that the flat plate with the wall plate is the highest choice compared to all other models, while a flat slab with bracings remains the second choice.

Key Words: Flat Slab, Shear Wall, Bracing System, Seismic Loads, E-TABS.

1.INTRODUCTION

The problem of the area in city regions has expanded the vertical improvement including the low rise, high rise, and tall building. In general, the framed structure is used for the construction of such buildings. The framed structure is subjected to vertical in addition to lateral loads. The lack of framed action in the flat slab structure results in instability in the structure in the seismic zone. Thus, such structures are greater vulnerable to earthquake loads. So, there's a want to carry out the seismic evaluation of the flat slab structure. Thus, the buildings that are designed for vertical loads may not stand for the lateral loads and can fail for the duration of an earthquake. In many earthquakes inclined regions, the buildings had been failed which aren't designed for

earthquake loads. Thus, all this situation made the seismic evaluation of the structure of high-quality importance. The flat slab construction technique is these days is having ease in India. Due to many improvements consisting of the benefit of construction, the time required for construction and clearer floor to floor height due to the absence of beam has expanded using the flat slab structure. By combining the flat slab structures with some structural factors can show good results. The structural addition including shear wall and bracing can be used with the structure. Six models of the flat plate with shear partition and flat slab with bracing (G+8), (G+10) &(G+12) storied buildings are designed and completed response spectrum analysis. In this work shear, wall, and bracing systems of structures are taken attention and achieved for lateral forces.

1.1 Flat Slab

A flat reinforced concrete slab, also known as a beamless slab, the slab at rests once on the column, and the load from the slab is now transferred to the columns and then to the foundation. To help the heavy hundreds, the thickness of the plate near the help with the column is increased and the people are called drops or columns. they usually come with enlarged heads known as column heads.

1.2 Shear wall

The shear wall is a structural element used to withstand lateral forces designed to withstand in-plane. lateral forces, commonly wind and seismic hundreds. Withstands hundreds from the cantilever. In different words, wall panels are vertical factors of the horizontal pressure resistance system. In this work RC type of shear wall is used. RC shear partitions are extensively utilized in medium-high houses for providing the lateral force, the rigidity and the current dissipation functionality are required. to stand as much as lateral hundreds springing up from wind or earthquakes.

1.3 Bracing

Bracing is a construction technique used to improve the overall bearing capacity of the building. Bracing structures consist of wooden or metal elements that help to evenly distribute the loads and increase the protection of the structure. In this work X- type of bracing is used in which two diagonal bars cross each other, it is known as

transverse reinforcement or X-reinforcement. This reinforcement must have tensile strength, and each reinforcement can withstand transverse forces.

2. OBJECTIVES

- [1] To examine and design flat plate structures with shear partition arrangements for different structure heights.
- [2] To analyses and design flat slab structures with bracing system arrangements for different building heights.
- [3] To know the seismic behavior of structures having shear wall and bracing systems.
- [4] To know the best suitable arrangement system to the structure whether it may be shear wall and bracing.

3. MODELLING

The methodology consists of the modeling and evaluation of the structure. Modelling of the flat plate with shear partitions & bracing building is achieved by using ETABS 2018 Software.

3.1 Structural Data Used

Table -1: Preliminary assumed data

Sr.No.	Content	Description
1	Building Stories	G+ 8, G+10, & G+12
2	Story Height	3m
3	Grade of Concrete	M-30
4	Steel Grade for (Main Bar)	Fe550
	Steel Grade for (Confinement Bars)	Fe 500
5	Column Size:	450x600
6	Flat slab Thickness	250mm (M-30, Fe550)
7	Bracing	ISMB 500 of type X-bracing
8	Dead Load	6.25 KN/m
9	Zone	Zone II (Hyderabad City)
10	Zone Factor	1
11	Site Type	(Type II) Medium- Soil
12	Importance Factor (I)	1.5
13	Response reduction Factor	5(SMRF)
14	Wind Load	IS875 (Part III)
15	Basic Wind Speed (Vb)	Zone II = 44 m/sec
16	Wind Co-efficient for Windward	0.8
	Wind Co-efficient for Leeward	0.5

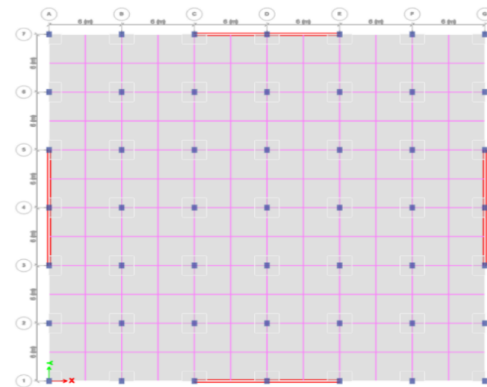

Fig -1: Flat slab with shear wall having (G+8) story building (Plan View)

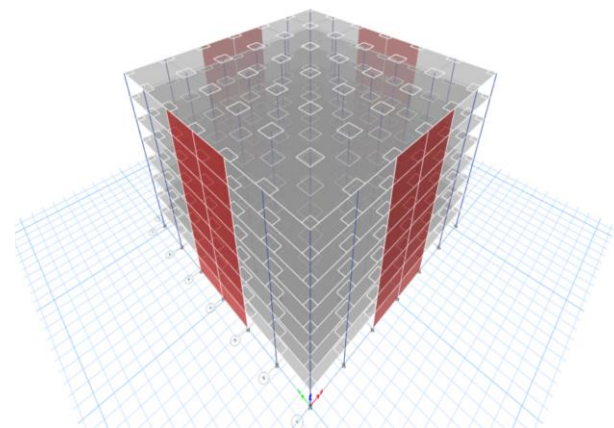

Fig -2: Flat Slab with Shear Wall having (G+8) story building (3D View)

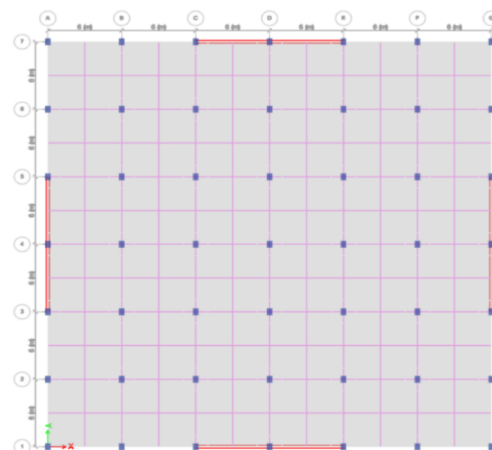
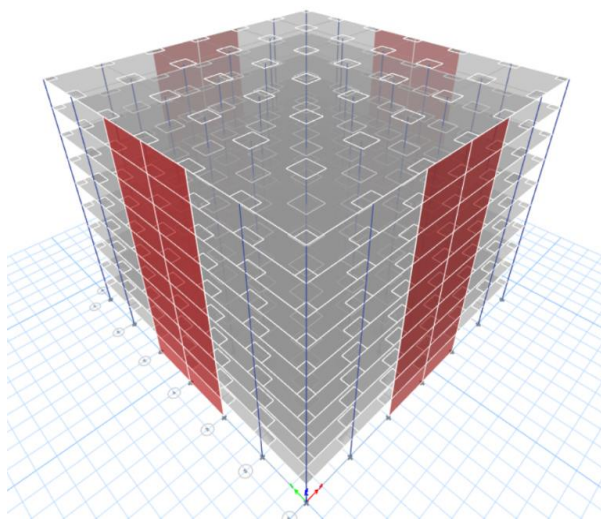

Fig -3: Flat Slab with Shear Wall having (G+10) story building (Plan View)

Fig -4: Flat slab with shear wall having (G+10) story building (Plan View)



building (3D View)

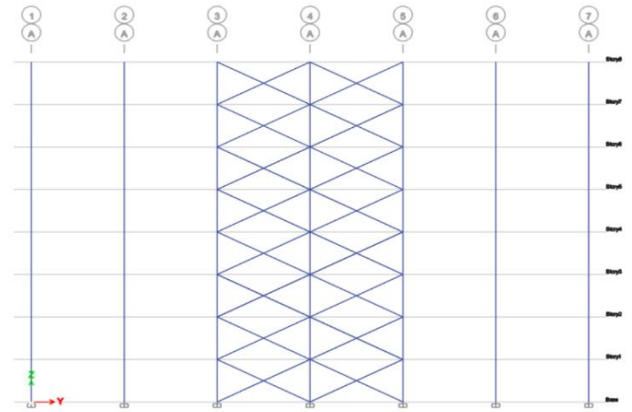

Fig -7: Flat slab with bracing having(G+8) storey building.

(Plan View)

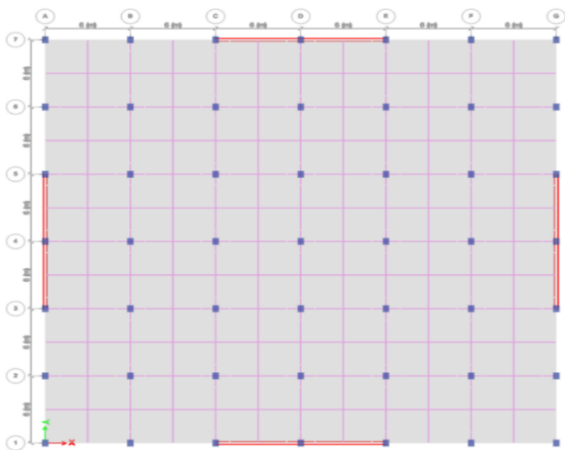

Fig -5: Flat slab with shear wall having(G+12) story building (Plan View)

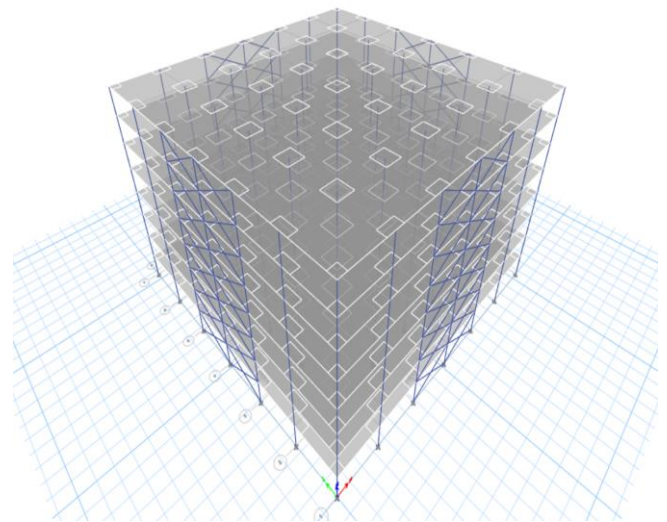

Fig -8: Flat slab with bracing having(G+8) story building (3D View)

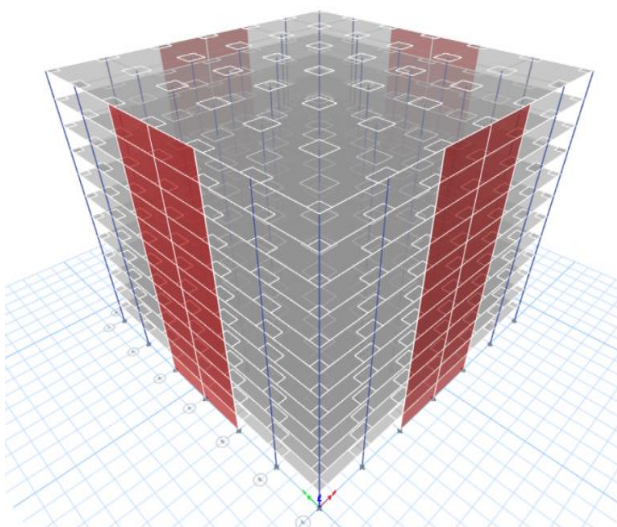

Fig -6: Flat slab with shear wall having(G+12) story building (3D View)

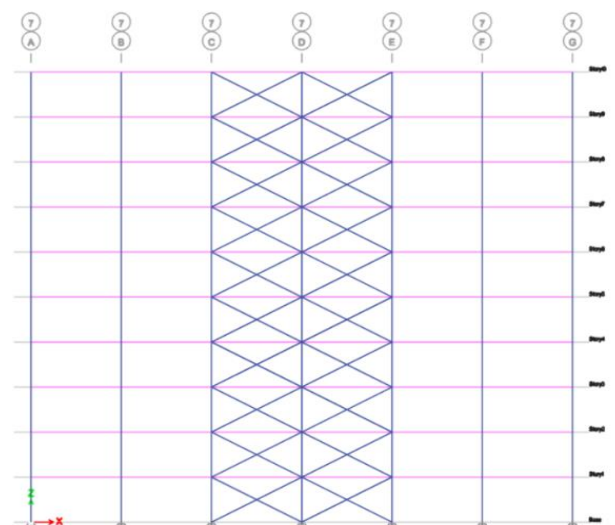

Fig -9: Flat slab with bracing having(G+10) story building (Plan View)

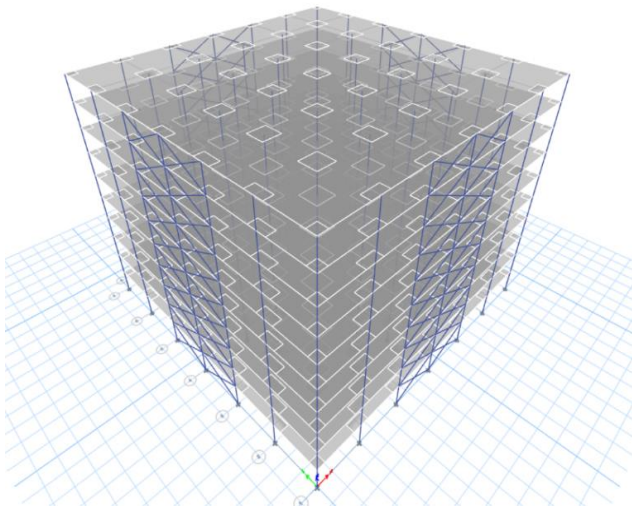

Fig -10: Flat slab with having (G+10) story building (3D View)

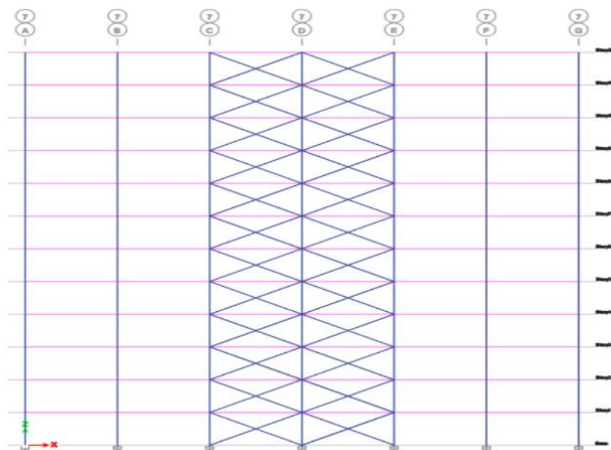

Fig -11: Flat slab with bracing having(G+12) story building (Plan View)

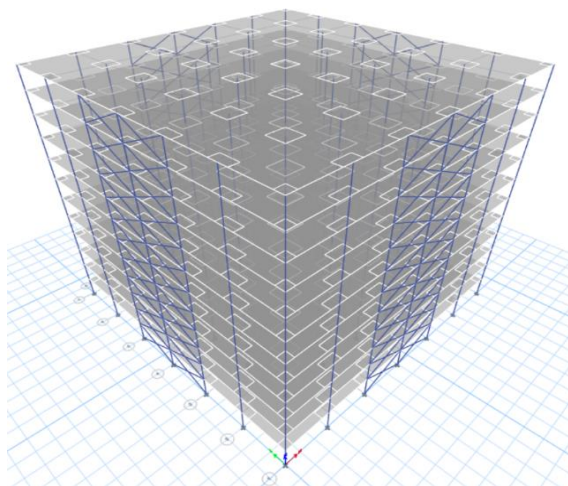

Fig -12: Flat slab with bracing having G+12 story (3D View)

4. ANALYSIS RESULTS

The present work carried out on the comparative investigation of the construction of flat slabs with shear wall and bracing systems for different Building heights. An overall of 6 models of systems is used for the dynamic evaluation of the use of the response Spectrum Method. The Code used is IS1893 part-I -2016 for the response Spectrum Method, from which the outcomes of Story Displacement, Storey Shear, Story Drift, & Story Stiffness for seismic zone II are obtained.

4.1. Storey Displacement for (G+8):

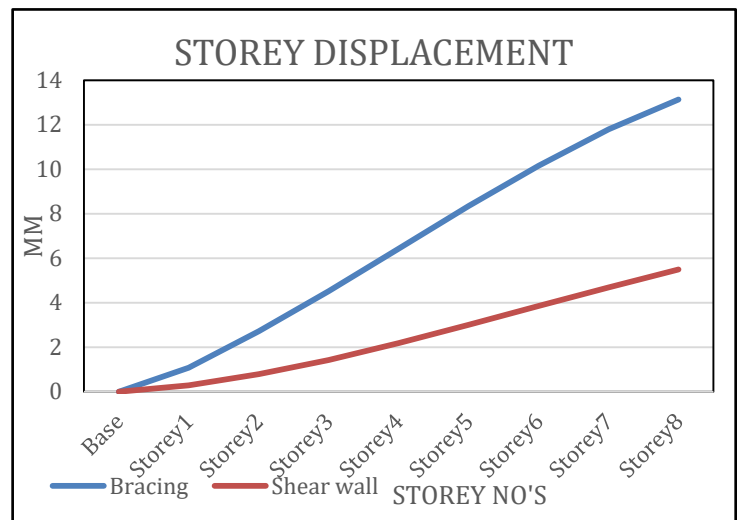

Fig -13: Story Displacement for(G+8) story building

The above graph shows that maximum displacement occurs for the structure that a bracing system has due to stiffness or resistance to lateral forces high, if we compare this structure with shear wall. We can see there is a difference between storey displacement of the shear wall and bracing system, for example at storey8 the value of storey displacement for bracing is maximum i.e., 13.141mm and for shear wall i.e.,5.494mm. A flat slab with a shear wall structure is more desirable than a flat slab with a bracing structure because story displacement is found to be less.

4.2 Storey Displacement for(G+10)

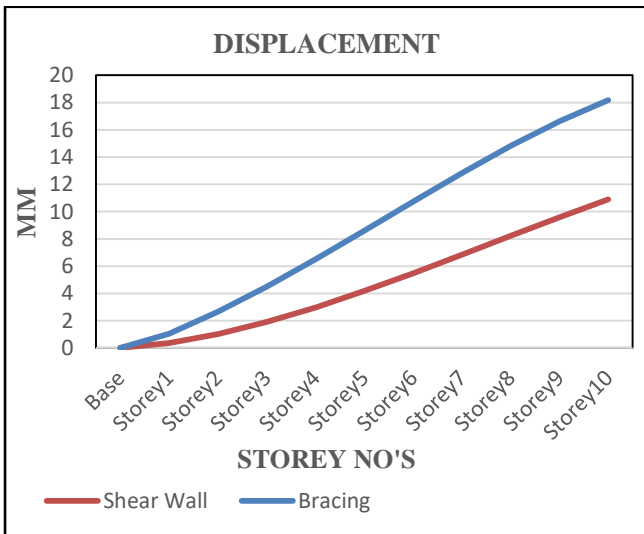

Fig -14: Story Displacement for(G+10) Storey building

The above graph shows that maximum displacement occurs for the structure that a bracing system has due to stiffness or resistance to lateral forces high, if we compare this structure with shear wall. We can see there is a difference between storey displacement of the shear wall and bracing system, for example at storey10 the value of storey displacement for bracing is maximum i.e., 18.171mm and for shear wall i.e.,10.903mm. A flat slab with a shear partition structure is more desirable than flat slab with bracing structure because story displacement is found to be less.

4.3. Storey Displacement for (G+12):

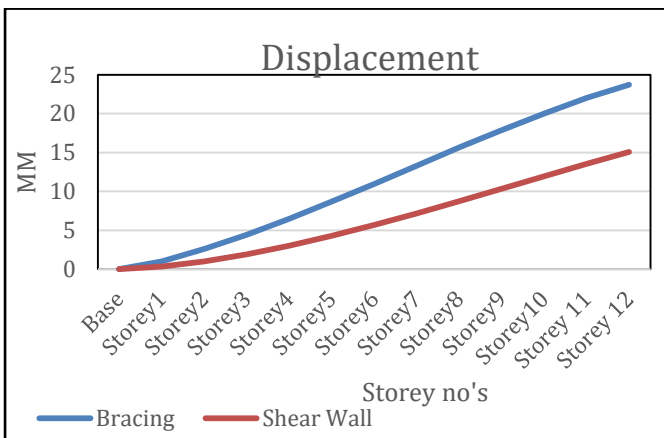

Fig -15: Story Displacement for (G+12) Storey building

The maximum displacement occurs for the structure that a bracing system has due to stiffness or resistance to lateral forces high, if we compare this structure with shear plate. We can see there is a difference between storey displacement of the shear

partition and bracing system, for example at storey12 the value of storey displacement for bracing is maximum i.e.,23.73mm and for shear partition i.e.,15.09mm. A flat slab with a shear wall structure is more desirable than a flat slab with a bracing structure because story displacement is found to be less.

4.4. Storey Stiffness for (G+8):

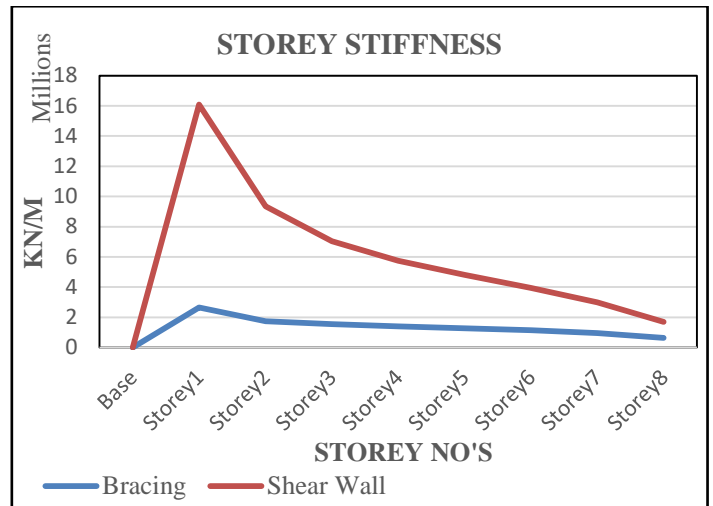

Fig -16: Story Stiffness for (G+8) storey building

The above graph shows, maximum stiffness of the structure having flat slab with shear wall at story 1, i.e 16075530.37 KN / M and the minimum stiffness of the structure having bracing system at storey 1, i.e., 2661172.347 KN/M. Flat plate with shear partition structure is better than flat slab with bracing building because story stiffness is found to be more.

4.5. Storey Stiffness for (G+10):

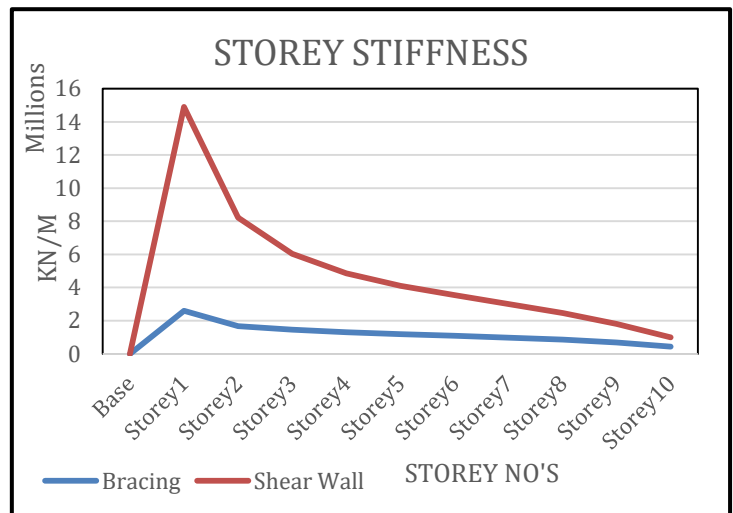

Fig -17: Story Stiffness for(G+10) Storey building

The above graph shows the story stiffness for (G+10) structure with Shear partition & bracing system, that maximum stiffness building having Flat plate with shear partition at storey 1, i.e., 14896681.1KN / M and the minimum stiffness structure having bracing system at story 1, i.e., 2598589.4KN/M. Flat slab with shear partition structure is better preferable than flat plate with bracing structure because storey stiffness is found to be more.

4.6. Storey Stiffness for (G+12):

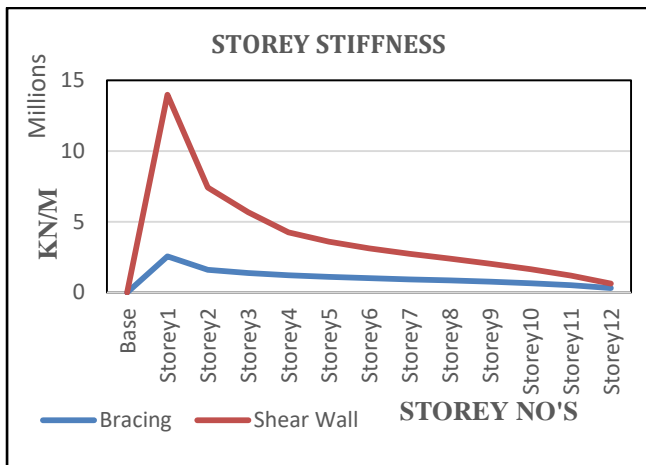

Fig -18: Story Stiffness for(G+12) Story Building

The above graph shows that maximum stiffness of the structure having flat plate with shear partition at storey 1, i.e., 13972018 KN / M and the minimum stiffness of the structure having bracing system at storey 1, i.e., 2549525.6 KN/M. Flat slab with shear partition structure is better than flat plate with bracing structure because storey stiffness is found to be more.

4.7. Storey Shear for (G+8):

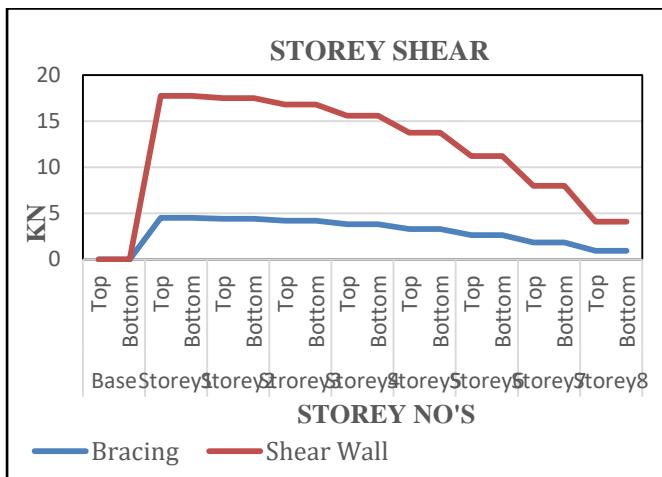

Fig -19: Story Shear for(G+8) Story Building

The above graph shows that maximum shear building having flat plate with shear partition at story 1, i.e., 17.748 KN and the minimum shear of building having bracing system at story 1, i.e., 4.513 KN. Flat slab with shear wall structure is better than flat slab with bracing structure because storey shear is found to be more.

4.8. Storey Shear for(G+10):

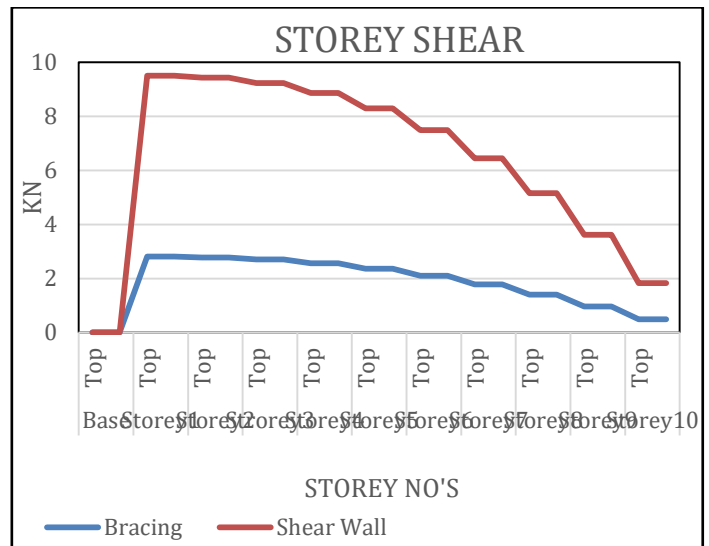

Fig -19: Story Shear for (G+10) Storey Building

The above graph shows, maximum shear of the structure having flat plate with shear partition at storey 1, i.e., 9.5 KN and the minimum shear of the structure having bracing system at storey 1, i.e., 2.81 KN. A flat slab with a shear partition shape is ideal than a flat plate with a bracing shape due to the fact story shear is discovered to be more.

4.9. Storey Shear for (G+12):

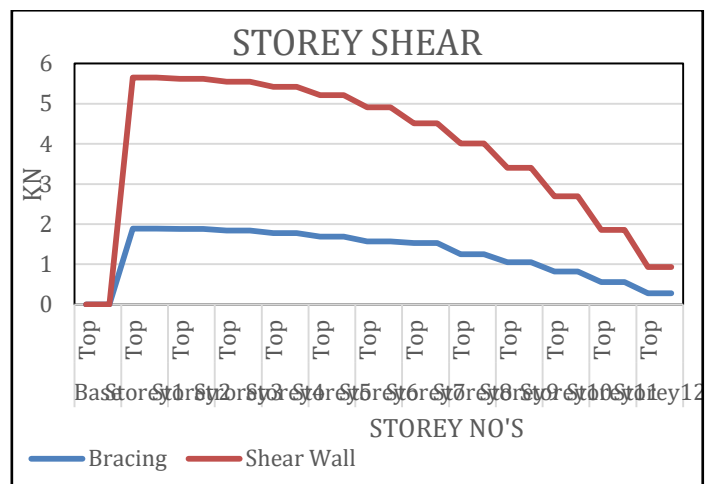

Fig -21: Story Shear for(G+12) Storey Building

The above graph shows, maximum shear of the structure having flat plate with shear partition at story 1, i.e., 5.65 KN and the minimum shear of the structure having bracing system at story 1, i.e., 1.89 KN. A flat slab with a shear partition shape is greater appropriate than a flat plate with bracing shape due to the fact story shear is located to be greater.

4.10. Storey Drift for (G+8):

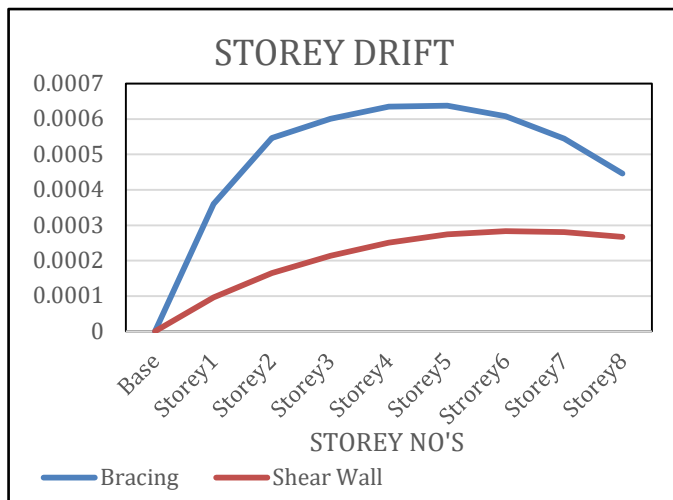

Fig -22: Story Drift for G+8 Storey Building

The above graph shows that story drift follows a parabolic direction together with the story height, with the maximum value someplace close to the central story. From the above graphs, it becomes found that story go with the drift of flat slab with shear partition building is less than a flat slab with the bracing system.

4.11. Storey Drift for(G+10):

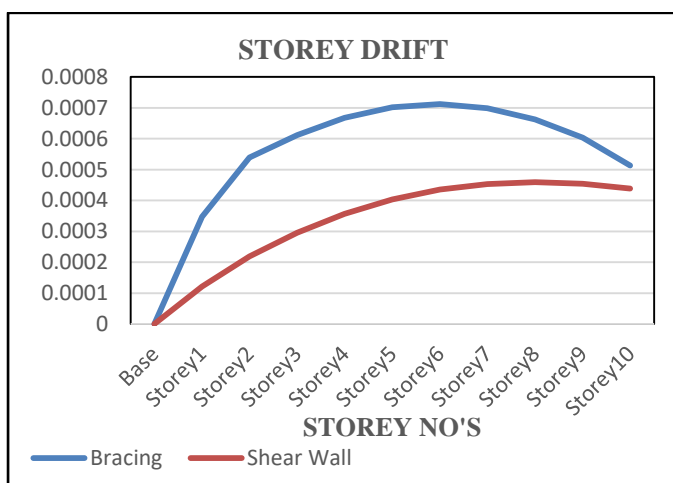

Fig -23: Story Drift for (G+10) Storey Building

The story drift follows a parabolic direction together with the story height, with maximum value

someplace close to the central story. From the above shows That story float of the flat slab with the bracing device is extra than a flat plate with shear partition device the peak of the constructing increases and cost of the story drift additionally decreases.

4.12. Storey Drift for(G+12):

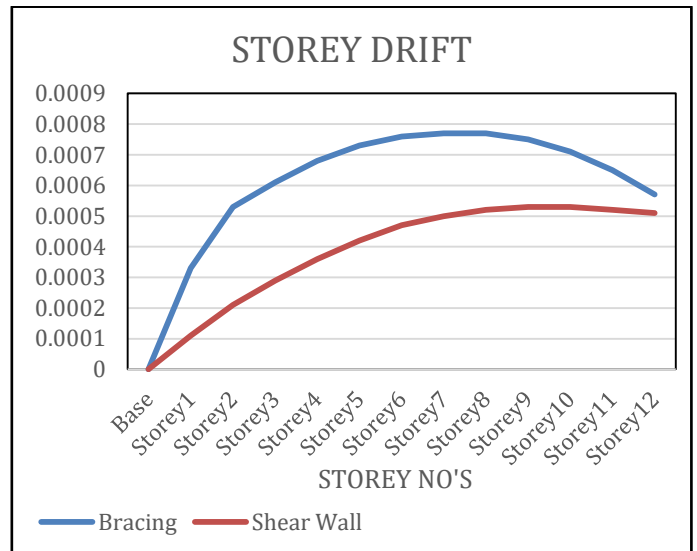

Fig -24: Story Drift for G+12 Storey Building

The above graph suggests that story waft of the flat plate with the bracing machine is extra than a flat slab with shear partition machine height structure increases, and price story waft moreover decreases.

5. CONCLUSION

The analysis of buildings with floors (G + 8), (G + 10), & (G + 12) is carried out with a flat ceiling system with shear partitions and Bracing system, following conclusions are drawn from the study:

- 1) Story displacement is most at the pinnacle tale and as a minimum at the bottom of the structures. As the constructing peak increases, the price of displacement furthermore increases.
- 2) The shape has the most tale displacement for a flat slab with the bracing gadget in comparison to the flat slab with the shear wall.
- 3) The tale float flat plate with shear partition manufacturing is less than flat plate with the bracing gadget. The price of tale float is most somewhere, near the significant tale. The values of tale float are within the permissible limit, i.e., now no longer extra than 0.004 instances the tale peak in step with the requirements in step with IS 1893: 2002 Part 1.

4) The tale shear values of the flat slab with shear wall shape indicates most price in comparison to the flat slab with bracing shape.

5) The stiffness of the shape with the bracing gadget could be very low in comparison to a shape with a shear wall. With growing constructing peak the price of the tale stiffness additionally decreases.

6) From the assessment of various parameters, the flat plate with shear partition effects with the values Story Displacement and Drift is decreased and the values of Story Stiffness and Shear is better than flat plate with the bracing system.

7) It can be terminated that flat plate with the shear partition is higher preference as compared to all different models, at the same time as a flat plate with bracings stays the second one preference.

6. FUTURE SCOPE

1) I have studied only four major Parameters i.e., Story displacement, Story drift, Story Stiffness, and tale shear. The volume of work undertaken this have a look at is restricted to comparison of seismic reaction parameters in a constructing with different shear partition places the usage of dynamic analysis.

2)The examination can be extended through inclusive of diverse different parameters inclusive of torsion effects and soft story effects in a building.

7. REFERENCES

1. Luo Y. H., Durrani A. et.al., "Seismic Reliability Assessment of Existing R/C Flat-Slab Buildings", American Society of Civil Engineers (ASCE), Volume 10, 2015.
2. Dr. Rame Gowda M., Tech Tata, "Study of Seismic Behaviour of Buildings with Flat Slab", International Research Journal of Engineering and Technology (IRJET), Volume 03, Issue 09, Sep. 2016.
3. Navyashree K., Sahana T. S., "Use of Flat Slabs in Multi Storey Commercial Building Situated in High Seismic Zone", International Research Journal of Engineering and Technology (IRJET), Volume 03, Issue 08, Aug 2014.
4. Pradip Lande S., Aniket Raut B., "Seismic Behaviour of Flat Slab Systems", Journal of Civil engineering and Environmental technology, and Advanced Engineering Volume 02, Issue 10, October 2012.
5. Dr. Uttamasha Gupta., Shruti Ratnaparkhe., Padma Gome., " Seismic Behaviour of Buildings Having Flat Slabs with Drops" International Journal of Emerging

Technology and Advanced Engineering Volume 2, Issue 10, October 2012.

6.Rameshkumar H Mali., Shreepad Desai., "Performance of Flat Slabs & Flat Plates in High Seismic Zone with Varying Stiffness" International Research Journal of Engineering and Technology (IRJET), Volume 05, Issue 08, Aug 2018.

7. P. Srinivas ulu., A. Dattatray Kumar., "Behaviour of RCC flat slab structure under earthquake loading" International Journal of Engineering & Science Research (IJESR), Volume 05, Issue 07 July 2015

8. Sudhir Singh Bhaduria., Nitin Chhugani., "Comparative Analysis and Design of Flat and Grid Slab System with Conventional Slab System", International Research Journal of Engineering and Technology (IRJET) Volume 04, Issue 08, Aug 2017

9. Md. Samdani Azad., Syed Hazni Abd Gani., "Comparative Study of seismic analysis of multistory buildings with shear walls and bracing systems", International journal of advanced structures and geotechnical engineering, vol. 05, no. 03, July 2016

10. Sukanya Sawant., K.R. Dabhekar., "Seismic Analysis of Flat Slab Structure" International Journal of Science Technology & Engineering, Volume 2, Issue 11 |, May 2016

Standard Codes:

- 1) BIS, IS456: 2000, - Plain and Reinforced concrete code of practices, Bureau of Indian standards, Fourth Revision.
- 2) BIS, IS1893: 2002 (Part I), - Criteria for Earthquake Resistant Design of structures, Bureau of Indian standards, Fifth Revision.
- [3] BIS, IS875: 1987 (Part III), - Code of Practice for Wind loads bureau of Indian standards.