

IoT based Covid Patients Health Monitoring in Quarantine

Ratnakala Patil^[1], Soujanya^[2], Rashmi^[3], Sowmya^[4]

¹Professor, Department of Computer Science and Engineering, Godutai Engineering college for women kalaburagi, Karnataka (India)

²Student, Department of Computer Science and Engineering, Godutai Engineering college for women kalaburagi, Karnataka (India)

³Student, Department of Computer Science and Engineering, Godutai Engineering college for women kalaburagi, Karnataka (India)

⁴Student, Department of Computer Science and Engineering, Godutai Engineering college for women kalaburagi, Karnataka (India)

Abstract - In The principle focal point of the strategy is to execute a replica for the continuous patient inspection framework. The proposed strategy is utilized to gauge the actual boundaries like internal heat level; heart beat rate, as well as Blood pressure observing through the assistance of biosensors. Routinely there is numeral of strategies accessible for the ICU patient's wellbeing checking framework through wired correspondence innovation. In the intelligent framework the patient wellbeing is persistently checked plus the obtained information is sent to a utilizing Wi-Fi remote sensor organizations. Implanted processor upholds for breaking down the contribution as of the patient and the consequences of the relative multitude of boundaries be put away in the information base. On the off chance to any irregularity felt by the patient signs will ship off the clinical authorities. The execution of the framework is accomplished via the elevated level ARDUINO microcontroller as well as reenactment outcome are gotten.

Key Words: IOT, ARDUINO, Heartbeat Sensor, Easy Pulse, Photo Plethysmo Graphy (PPG)

1. INTRODUCTION

Numerous structures for far off wellbeing checking method were created in the new years, for instance, advanced cell based distant wellbeing observing application. In far off medical services checking application we can't utilize the accessible broadcast capacity effectively, assuming to we utilize the conventional method of communicating the information persistently. It lessens the hub life time, even prompts disappointment of information because of postponement as well as cradle over-burdening, which isn't satisfactory especially in medical services application. The issue to happen because of the ill-advised information affiliation gathered as of patient has been talked about. The engineering planned is comprises of a focal door which assemble the information as of every one of consumers plus send it to the focal server occasionally, where clinicians can characterize the consumers wellbeing status. In this manner, a specific interest is centered on persistent checking procedures. Not at all like the spot checking, this sort of observing can giving long haul statistics about the patient, assist through recording crisis circumstances plus respond adequately to any critical modify face to face's

medical issue in an ongoing. Medical services be momentous piece of day to day existence for all people in world. Every one of us require an intermittent observing of basic boundaries as well as right medicines reliant on this information. These cycles become considerably more critical when individuals achieve a meticulous age as well as can't follow their ailment appropriately lacking an exceptional clinical select or modern hardware to play out the observing the more seasoned individual gets the more extensive range of potential sicknesses plus sudden crisis circumstance might happen. To stay away as of this, the individual must be happy to the clinic, seen via clinical staff as well as furnished with prompt assistance in the event to a portion of limits portion strange.

1.1 RELATED WORK

S. M. Riazul islam et al [1] propose a smart shared safety replica to limit security hazard; examine how assorted advancement like enormous information, encompassing knowledge, as well as wearable can be utilized in a medical concern setting; addresses dissimilar IoT as well as E-Health arrangements plus strategy across the world to decide how they can work through economies as well as social instructions as far as maintainable turn of events; plus give a few roads to future exploration on IoT-put together medical care based through respect to a bunch of open issue as well as difficulty.

Junaid mohammed et al [2] screen patient's ECG wave anyplace on the planet utilizing IOIO-OTG Microcontroller. Android application is made for ECG monitor. IOIOTG microcontroller is associated through android telephone utilizing USB link (or) Bluetooth dongle. Subsequent to assembly information, the wave is ship off android application. Screen as well as store ECG waves in to android based application.

Mohammed S. Jasses et al [3] zeroed in on internal heat stage observing utilizing Raspberry pi board in cloud based framework. In this paper, Raspberry pi is screen internal heat height plus afterward these boundaries be move via wireless sensor network (WSN). Then, at to tip, these information's be added to the cloud based sites. Utilizing this site screen body warmth.

Hasmah Mansor et al [4] screens internal heat level utilizing LM35 temperature sensor. The LM35 hotness sensor is associated through the Arduino uno board. After to making a site in SQL statistics set pattern. Arduino uno board is linked through to site. Then, at to tip, sensor yield is ship off the site. Utilizing this site anyone can screen internal heat height in login procedure.

1.2 SYSTEM ARCHITECTURE

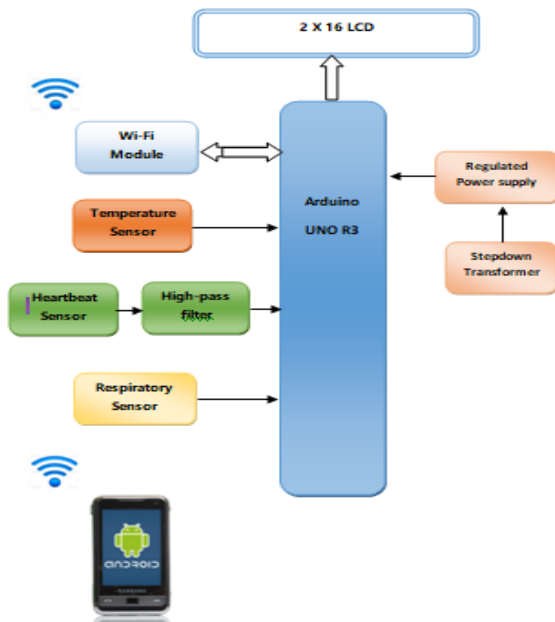

Fig 1: SYSTEM ARCHITECTURE

From the above outline 1, the planned framework engineering comprises of two principle unit in particular screen unit, sensor unit. The sensor unit secures the multi parametric clinical information, for instance, internal heat level, Blood pressure; heart beat as well as so forth as of assorted sensors utilizing dissimilar sign handling method. Enhanced proactive examination can be specified provided to the information gathered as of the patient is arranged appropriately. The gather boundaries be specified to regulator unit. It looks at gathered information esteems to unique qualities. In case any deviation happens, it produces control sign to patient through Buzzer. For scrutiny reason LCD show is utilized. Other concern, the Internet of Things (IoT) structure face is the anyplace or omnipresent accessibility, chiefly in Wireless Body Area

Network (WBAN) application where the patient is must encompass been under consistent watch of the clinicians for proactive finding. Bluetooth, ZigBee as well as Wi-Fi are the essential set-up of undeniable level correspondences utilized in WBANs. WBAN frameworks would need to guarantee consistent information move across norms like Bluetooth LE, ZigBee and Wi-Fi and so on to advance statistics trade, fitting as well as play gadget collaboration. ZigBee plus Bluetooth LE aids low

energy utilization through low information rate however offers tremendously low reach contrasted through Wi-Fi. Being a non-static consumer under checking, the odds of consumer loosing accessibility via intersection the reach is exceptionally elevated which makes the conveyance of proactive verdict a troublesome angle.

1.3 SYSTEM ANALYSIS

1.3.1 EXISTING SYSTEM

In existing framework, FPGA based universally associated distant wellbeing checking application through savvy broadcast system was presented. This FPGA based equipment engineering of versatile principle motor is require two 16 cycle comparators, two 3 bit adders, one 3 digit comparator plus one 16 bit subtracter. The 16 digit subtractor sequentially works out the PR, QRS as well as QT information instance period signal as of their split beginning as well as end focuses commencing the information. For scrutiny reason, the sign procurement obtain ECG information as of patient. ECG information of 20 patients through assorted age bunches were checked as well as afterward the assessed outcome be contrasted through unique qualities.

1.3.2 PROPOSED SYSTEM

In the proposed framework the patient is observed utilizing Wi-Fi. It diminishes the radio impedance in human body. Patient is observed utilizing assorted sensors like warmth, heart beat as well as movement sensor. The detected information is then distorted over keen on advanced structure in the microcontroller. The outcome of the microcontroller is shipped off the Wi-Fi module. The information is then sent as light through the Wi-Fi module plus consumer can screen via utilizing IoT cloud application (BLYNK). The concerned individual can get to the information of the patient utilizing the versatile application information checking utilizing Wi-Fi.

2. OBJECTIVES

1. To lessen the conveying heap of the treatment subtleties as well as the records.
2. To foster an incorporated plus disseminated server and statistics set where the information is divided amongst assorted servers
3. To give assist to patients at home when there is nobody next to them.
4. To likewise personal the relative of patient plus the closest medical clinic so they be there when needed.
5. Online patient wellbeing limits scrutiny

2.1 IMPLEMENTATION



FIG 2: Heart Beat sensor

2.1.1. Heart Beat Sensor: Heart beat sensor is intended to give advanced consequence of hotness thump when a finger is set inside it. This computerized outcome can be linked through Arduino straightforwardly to gauge the Beats each Minute (BPM) rate. It deals through the standard of light regulation via blood move through finger each heartbeat. IC LM358 is utilized for this sensor. Its double low power functional intensifier comprises of a very radiant red LED as well as light indicator. One will go about as speakers plus one more resolve be utilized as comparator. Driven must be actually luminous as the light must go through finger as well as distinguished at opposite end. At the tip when heart siphons a beat of blood through veins, finger turn out to be somewhat more obscure so less light reach at the indicator. Through each heart heartbeat, the finder gesture differ which is distorted over to electrical heartbeat.

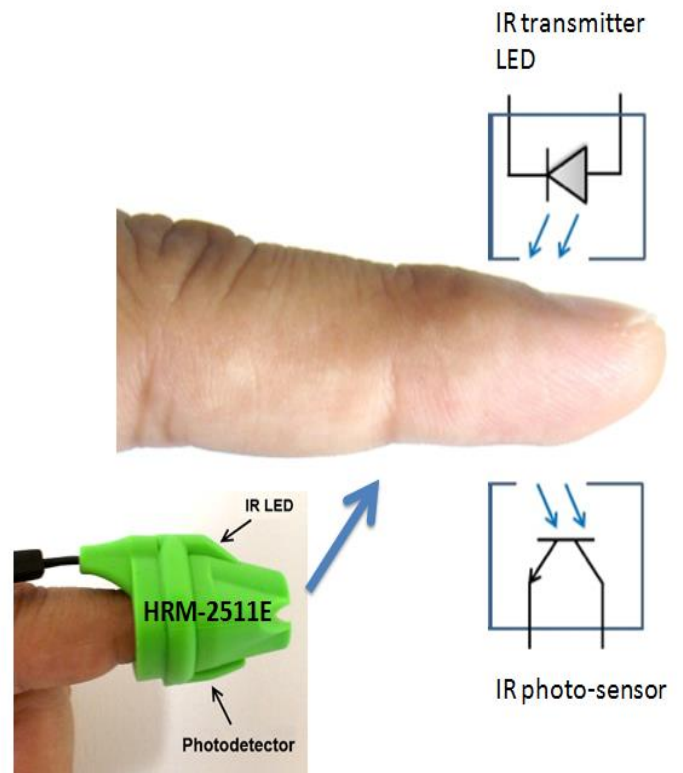

FIG 3 Transmission PPG Probe

2.1.2. Easy Pulse: The Easy Pulse sensor is intended for side interest as well as instructive application to outline the Standard of photo plethysmo graphy (PPG) as a non-intrusive optical procedure for identify cardio-vascular heartbeat wave as of a fingertip. It utilizes an infrared light source to enlighten the finger on one side, and a photo detector set on the opposite side estimate the little varieties in the sent light power. The varieties in the photo detector gesture are recognized through change in blood volume inside the tissue. The sign is alienated as well as enhanced to get an overall quite clean PPG waveform, which is synchronized through the heart beat. The primary shape of Easy Pulse utilizes the TCRT1000 intelligent optical sensor to notice the blood variety in finger tissue plus outcome a computerized beat which is coordinated through the heart beat. Today, we are satisfied to announce the arrival of Easy Pulse Version 1.1, which has a few upgrades over the first plan. The novel appearance gives mutually simple PPG waveform just as advanced heartbeat gesture as isolated outcome. Simple Pulse Version 1.1 board is accessible for buy on Tindie. As of late, our Chinese merchant Electro has likewise begun selling it for \$18.50, as well as they can propel it worldwide at inferior cost.

2.2 Data Flow Diagram

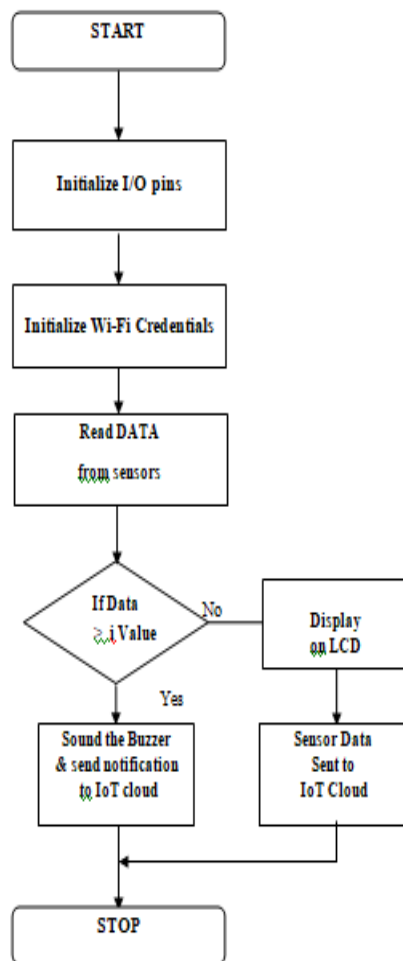

FIG 4: Data Flow Diagram

2.3 ADVANTAGES

1. Bridging the hole among the specialist as well as patients.
2. Preeminent to be utilized on provincial areas.
3. It is a multipurpose so usually speaking circumstance is effectively calculated.
4. Simple to operate.
5. Compare through reduced sensor it gives improved performance.

2.4 Disadvantages

1. Battery might release speedy, because of consistent use.

3. Results

In this work DS1820 warmth sensor and heartbeat sensor is utilized to peruse the warmth as well as pulse of patient plus microcontroller get the information moreover send it through Wi-Fi. The information is additionally shipped off the LCD for show so quiet or medical service can know his wellbeing status. During outrageous circumstances to caution the specialist message is shipped off specialist's PDA through Wi-Fi (IoT) modem linked and simultaneously the bell goes on to alarm guardian. The specialists can see the sent information via logging via html page utilizing remarkable logging ID through page reviving choice is specified so persistently information assembly is accomplished. Subsequently constant patient checking framework is skillful.

3.1 Conclusion

In this manuscript, we proposed a Wi-Fi based remote health monitoring as well as control system using atmega328 microcontroller, which is capable to continuously monitor the patient's heart beat, blood pressure as well as other critical parameter in hospital. We also planned a continuous monitoring plus manage mechanism to monitor the patient circumstance as well as store the patient statistics in server. For the performance valuation, simulation outcome be taken via using PROTEUS 7 simulation tool.

3.2 Future Work

Our future work is to explore the hardware multiplexing among the two radios plus achieves a momentous area reduction in enlargement of multiple radios base communication plans like an "IoT chipset". Envisaged IoT Chipset resolve encompass features like adaptive rule engine based smart broadcast technique to achieve low power as well as seamless hand-off controller (SHC) integrated for seamless hand-off among multiple on-chip radios to facilitate ubiquitous connectivity.

REFERENCES

- [1] S. M. Riazul islam, Daehan kwak, MD. Humaun kabir, Mahmud hossain, and Kyung-sup kwak, "The Internet of Things for Health Care: A Comprehensive Survey", DOI 10.1109/TDSC.2015.2406699, IEEE Transactions.
- [2] Junaid Mohammed, Abhinav Thakral, Adrian Filip Ocneanu, Colin Jones, Chung-Horng Lung, Andy Adler, "Internet of Things: Remote Patient Monitoring Using Web Services and Cloud Computing", 2014 IEEE International Conference on Internet of Things (iThings 2014), Green Computing and Communications (GreenCom2014), and CyberPhysical- pp 256-263, 2014
- [3] Mohammad S. Jassas, Abdullah A. Qasem, Qusay H. Mahmoud, "A Smart System Connecting e-Health Sensors and the Cloud A Smart System Connecting eHealth Sensors and the Cloud" Proceeding of the IEEE 28th Canadian Conference on Electrical and Computer Engineering Halifax, Canada, pp

712-716, May 3-6, 2015.

[4] Hasmah Mansor, Muhammad Helmy Abdul Shukor, Siti Sarah Meskam, Nur Quraisyia Aqilah Mohd Rusli, Nasiha Sakinah Zamery, "Body Temperature Measurement for Remote Health Monitoring System" IEEE International Conference on Smart Instrumentation, Measurement and Applications (ICSIMA) 26-27 November 2013.

[5] Afef Mdhaftar, Tarak Chaari, Kaouthar Larbi, Mohamed Jmaiel and Bernd Freisleben "IoT-based Health Monitoring via LoRaWAN", IEEE EUROCON 2017.

[6] K. Mathan Kumar, R.S. Venkatesan, "A Design Approach to Smart Health Monitoring Using Android Mobile Devices" IEEE International Conference on Advanced Communication Control and Computing Technologies (ICACCCT), pp 1740-1744, 2014.

[7] Soumya Roy, Rajarshi Gupta, "Short range centralized cardiac health monitoring system based on ZigBee communication", IEEE Global Humanitarian Technology Conference - South Asia Satellite (GHTCSAS) Trivandrum, pp 177-182, September 26-27, 2014.