

Design and Fabrication of underwater vehicle

Aashay Ingle¹, Balram Jha², Mandar Hegiste³, Varun Gharat⁴

^{1,2}UG Students Department of Mechanical Engineering, Viva institute of technology, vasai-virar, Maharashtra-401305, India

Abstract - Sub aquatic tugger is a rare vehicle designed to extract metallic objects such as ornaments, coins, etc., from the water reservoir or swimming pool. This vehicle consists of an arrangement of magnets at the base of the vehicle & makes use of pneumatic circuits. It is somewhat difficult to get out materials from the water bodies manually as there is pressure acting upon the body and due to the depth of the water. The metallic objects are pulled out from the water reservoir or swimming pool by using a set of magnets. Mainly the problem faced underwater is to get the location of the object; These problems are solved by using a camera the underwater objects can be visualized by the means of a camera. The camera will help us to navigate as well as it will help us to detect the object, which is under the water. The unit consists of a bladder that is attached to the tugger and the inlet side will be connected to the compressor, which will help the bladder to blow. The remote controller controls the vehicle; the remote controller gives the command to the thruster to work accordingly to need of the user.

Key Words: Tugger, Thruster, Camera, Magnet, Bladder

1. INTRODUCTION

We find that many objects or valuable things are immersed inside the water bodies which are really very difficult to be spotted (located) Also there are some places where humans cannot reach due to various reasons which can be present inside the water bodies. This unit is not only used for removal of the ferrous material from the water bodies but this unit can be used for navigation So it becomes necessary to be cleaned as it can cause serious problems to our environment.

Therefore, we are designing a SUB -AQUATIC TUGGER so that it will be easy to clean the water bodies. In addition, it would help to find the valuable things which are ferrous in nature we can remove them out with the help magnets. The unit (tugger) is a type of vehicle that can be controlled in every direction with the help of the controller. The underwater objects can be visualized by the means of camera. The camera will help us to navigate as well as it will help us to detect the object, which is underneath the water. The unit consists of a bladder that is attached to the tugger and the inlet side will be connected to the compressor, which will help the bladder to blow. As the metal or ferrous materials are detected the group of magnets will be attracted towards them after the attraction of the metals the compressed air will be passed and the bladder will blow and it will help to bring the metal on the surface.

We are designing the lightweight body the reason behind making low weight body is that it will help to move quickly. The Aluminum body is used such that it is very light in weight and it does not corrode. For the movement of the tugger, we are attaching thruster on both the side.

2. Literature Review

Sr No	AUTHOR NAME	TITLE	JOURNAL	YEAR OF PUBLICATION	OUTCOME FROM THE WORK
1	Huimin Lu; Yin Zhang; Yujie Li; Quan Zhou	Underwater Kinect Camera Using Inpainting and Local Image Mode Filtering	IEEE	2017	By using a camera, we can get the exact location of the object immersed in water and steer the Vehicle in the proper manner.
2	Muljowidodok K, SaptoAdi N, NicoPrayogo and AgusBudiyono	Design and Testing of Underwater Thrusters for SHRIMP POV-ITB	IEEE	2009	By using this technique, we can design a thruster that can provide a proper motion to our vehicle and turn the vehicle at the situated object.
3	A. Almasi	Reciprocating Compressor Optimum Design and Manufacture with Respect to Reliability and Cost	IEEE	2009	This paper suggests that we can use a reciprocating compressor instead of using any other compressor. As the reciprocating compressor is more efficient and low in cost. With the help of a compressor, we can uplift the vehicle above the water surface.

3. Calculation

It is difficult to lift the metallic objects from water. When any rigid body submersed in the water it experience the pressure of water and the load of atmospheric pressure. The submersible unit is made to go deep inside the water up to 4m. To find the pressure acting on the submersible unit we can use following formulae,

$$P_{\text{fluid}} = \rho gh$$

Where,

P_{fluid} : - pressure of fluid

ρ : - (rho) density of fluid

g : - force of gravity

h : - height

Then total force acting on the whole unit is,

$$P_{\text{total}} = P_{\text{atm}} + P_{\text{fluid}}$$

Where,

P_{total} : - total pressure acting on whole unit. P_{atm} : - atmospheric pressure acting on unit.

When submersible goes 4 m deep inside the water it experiences following pressure, $\rho = 1000$

$$g = 9.81 \text{ m/s}^2$$

$$h = 4 \text{ m}$$

4. Problem Description:

The water bodies are contaminated during festivals as well as the metallic objects fall inside the water. Also many times it happens that while swimming our valuable ornaments falls down in a swimming pool or in ponds and that immersed into the water and we are not able to navigate in deep water to find the object that is immersed into the water. This vehicle will help to navigate the metallic object also help to remove the object with the use of magnets.

5. Objective

To maintain healthy surroundings for aquatic life inside the water reservoir.

To locate various objects immersed inside the water reservoir as well as swimming pools.

To remove the precious ornaments and small objects like coins, inside the water bodies

To clean the water reservoir and swimming pool easily

6. Proposed metrology:

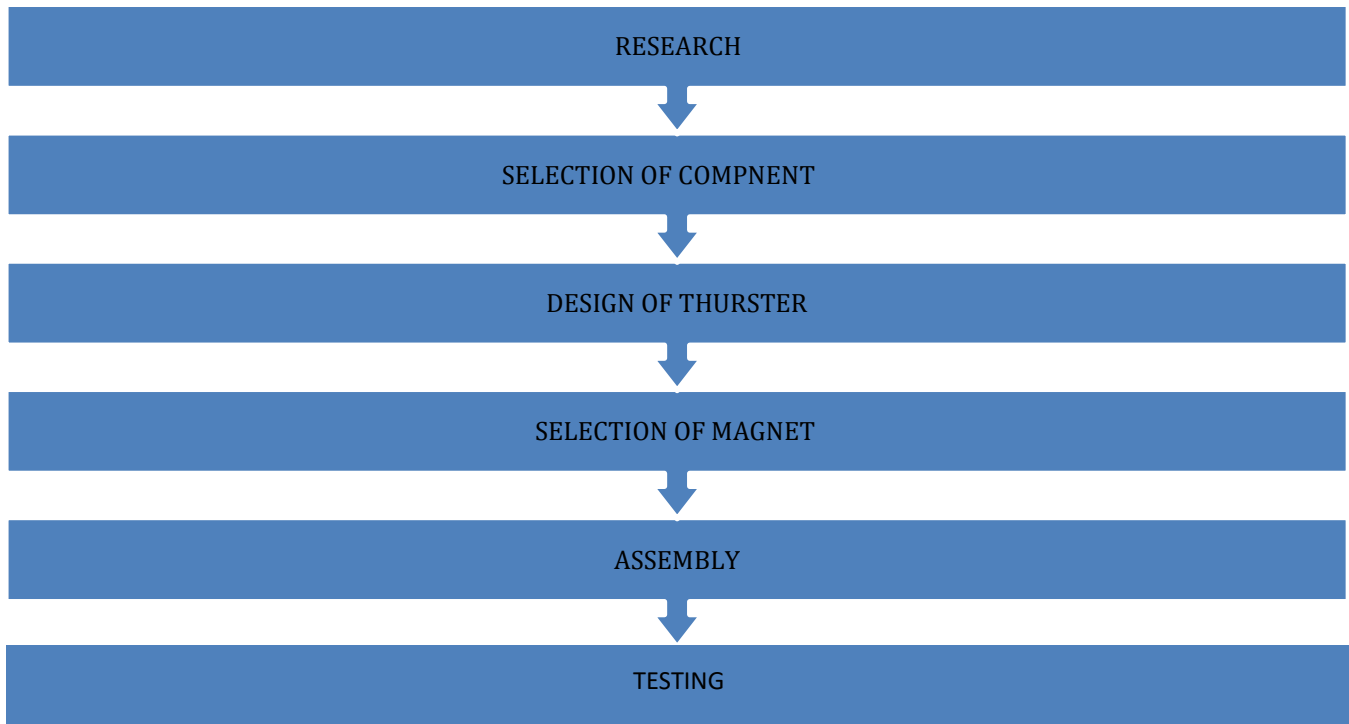

This is the top most commonly used plate. The top plate is attached to the machine. Where they are used for aliment of plate. This plate is connected to shank where the middle part is connect to press

We researched the components, which are required for making this project. We referred the research papers of the previous years. In addition, we got much information related to the components. We also referred to different sites that give us information on the principles, which can be used in this project.

FINDING GENUINE MATERIALS:

After research, we found out the types of materials, which can be used for the frame of the submersible unit we also found out the ability of the materials, which can sustain under the following conditions.

THRUSTERS:

As the name suggests external thrusters are attached to the frame. Thrusters are a transversal propulsion device built into a ship or a boat. Thrusters make docking easier since they allow the captain to turn the vessel to port or starboard side, without using the main propulsion mechanism, which requires some forward motion for turning.

We are using here two thrusters to give direction to all units inside the water. The function of the unit is to lift the metallic (iron) object from the water by using a set of magnets. For that, the unit must have to rest in that iron object. When this unit is launched from the floater, then it takes an inclined path in the water. Due to this unit cannot reach near the object.

Therefore, by using thrusters we can give the direction to the unit to reach near that object. To make this, thrusters we had used the electric motor of 1000 rpm. The blades of thrusters are made up of mild steel plate. The thrusters are connected at the frame.

MAGNETS:

For lifting, the ferrous material a set of magnets is used which will attach the metallic object. We have selected the magnet according to the basic application. The magnets are mounted at the base of the body by which metallic objects can easily attach to the magnets.

7. Objective

Floater:

The floater consists of a tripod structure. This structure is the basic structure of Sub-Aquatic Tugger. Triangular structure is stronger than the square structure. In our project, the tripod structure consists of triangle and three supporting legs. These legs are connected to the upper triangle & to the C-clamp. This tripod structure gives strength to entire unit.

Tripod structure is made up of aluminum blocks. A single aluminum block is used to make a tripod leg. However, a single block can't vary maximum load. Therefore, we had used mild steel plates, nut, and bolts for increasing the strength. The rubber tube is attached to the legs of tripod structure, which helps entire unit to float.

DIMENSIONS

Length (L) = 200mm Width (W) = 25mm Height (H) = 60mm

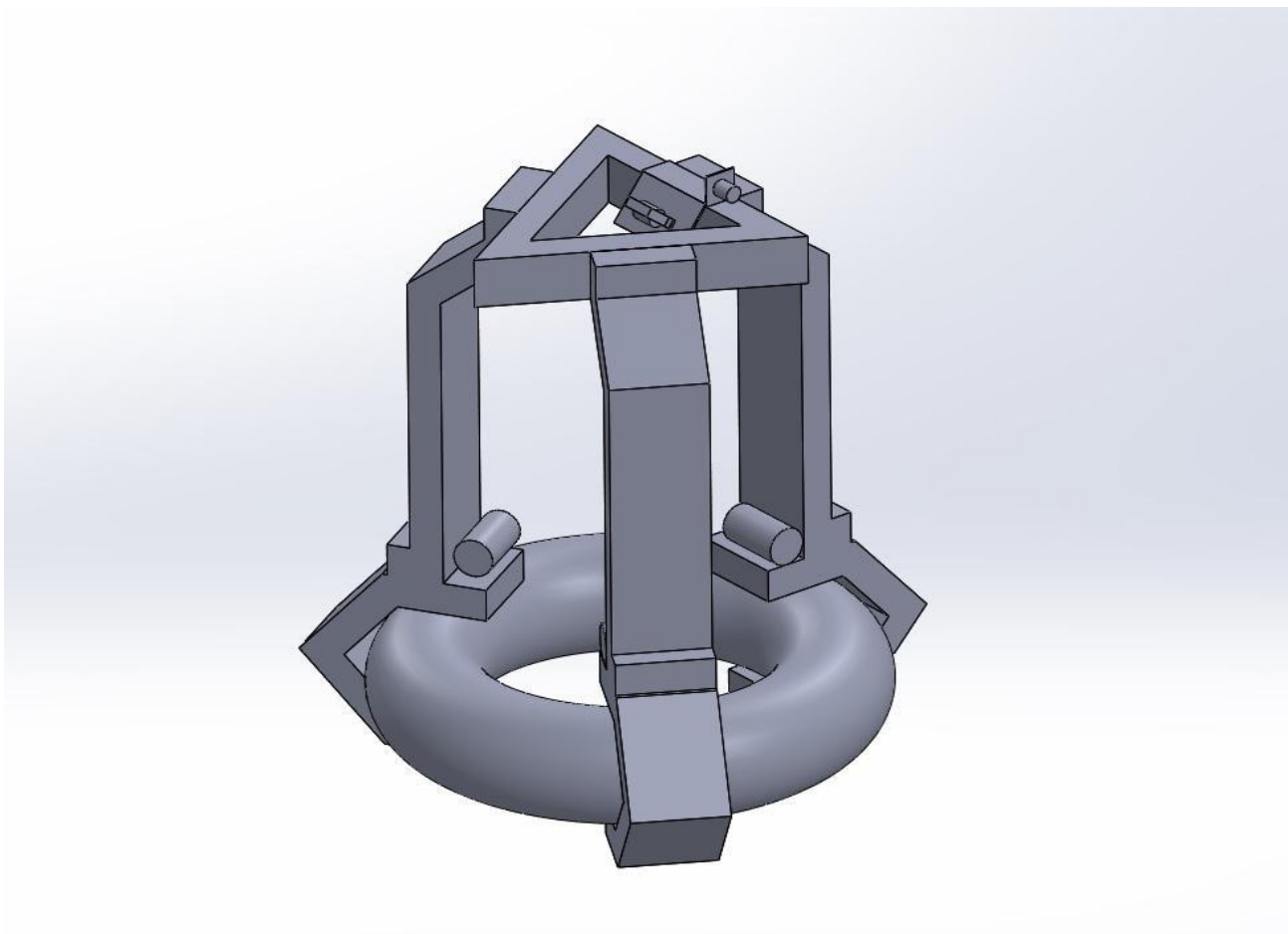

Fig -1: floater

Submersible unit

As the object has to be light in weight and strong in construction the material used is aluminum. The property of aluminum is that its weight is light and can easily float on the water surfaces. A tripod type shape is made as frame supports to hold the rubber tube that carries the vehicle a float.

Two parts of the project make the entire system work. First is the vehicle that carries the submersible part while the other is the submersed part itself. The submersible part is constructed somewhat like a triangle of aluminum with a base plate made up of steel. It carries a series of magnets again resembling a triangular arrangement.

A pipe coming from the compressor unit and is directed towards the center of the plate containing magnet arrangements and this pipe is connected to a rubber balloon that blows up. A manual control valve and regulator regulates the flow of pneumatic pressure manually

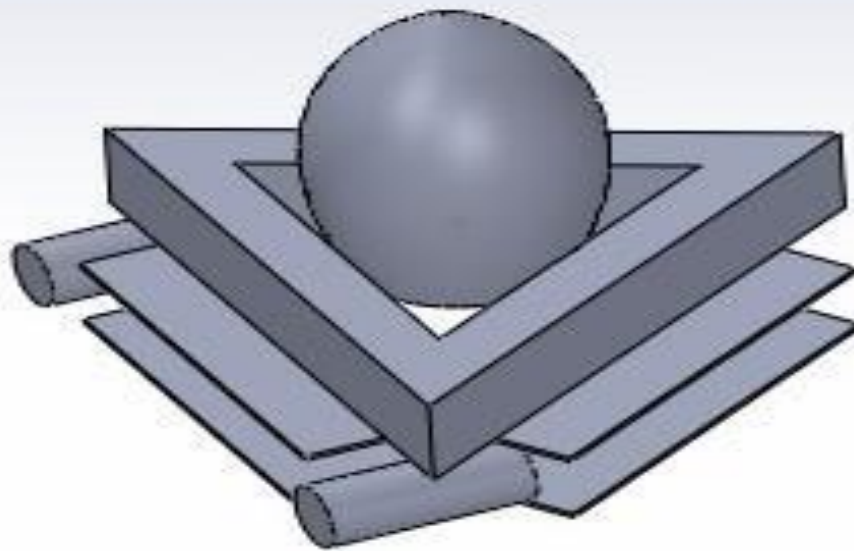

Fig -2: Submersible unit

8. CONCLUSIONS

As we have studied the project in detail, we can certify that a Sub-Aquatic Tugger can be used to lift the objects beneath the water surface at greater ease. The controlling of the project can be done over a range of a maximum of 10 feet via remote control. Furthermore, on wider necessities the size of the rubber tube and the entire project can be maximized. Mostly this project has a huge range of applications in a marine field.

As its cost is low industries, as well as a domestic unit can make use of this project to the maximum. It does not make use of external supply. We can conclude this project in working conditions ready for the welfare of human beings.

REFERENCES

1. Huimin Lu, Yin Zhang, Yujie Li, Quan Zhou "Depth Map Reconstruction for Underwater Kinect Camera Using Inpainting and Local Image Mode Filtering. 2017, pp 1-8
2. Muljowidodok K, SaptoAdi N, NicoPrayogo and AgusBudiyono. "Design and Testing of Underwater Thrusters for SHRIMP POV- ITB, VOL 38(3), 2009, pp 338-345
3. A. Almasi. "Reciprocating Compressor Optimum Design and Manufacture with Respect to Reliability and Cost, VOL 3, 2009