

DESIGNING OF AN ELECTRIC BIKE

Vatsal Shah¹, Chirag Bawle², Tanmay Vaghasiya³

¹⁻³Department of Mechanical Engineering, DJ Sanghvi College of Engineering

ABSTRACT: "We will not stop until every car on the road is electric"-By Elon Musk. As the adage suggests, electric bikes are becoming a new future for bike enthusiasts all around the world. There are various companies upcoming with exquisite bike designs. The electric power generated which is used to run the bike can give better fuel economy compared to conventional vehicle, better performance and also cause less pollution. This paper represents and delineates the designing part of an electric bike with all the components that are necessary to manufacture a commercial level e-bike. Every component is designed for attaining manufacturability and analytical results matching with the combustion bikes on the road.

KEYWORDS : Electric vehicle, Modelling, Factor of Safety, Analysis, Simulations, Battery management system

Contents

1. CHASSIS	1552
2. MOTORCYCLE GEOMETRY	1557
3. SUSPENSION	1559
4. BRAKES	1565
5. TRANSMISSION SYSTEM	1568
6. MOTOR AND BATTERY	1571
7. BODYWORKS	1573

1. CHASSIS

1.1 INTRODUCTION:

A motorcycle frame is a motorcycle's core structure. It supports the engine in this case the battery provides a location for the steering and rear suspension, and supports the rider and any passenger or luggage. At the front of the frame is found the steering head tube that holds the pivoting front fork, while at the rear there is a pivot point for the swing arm suspension motion. It is also the element responsible for the stiffness of the whole vehicle and how it handles and reacts. The main aim is to design a chassis which leads to good manoeuvrability, doesn't flex and is light weight. The frame has a static and a dynamic function. The static part concerns supporting the weight of the rider (or riders), the battery and transmission as well as all the other necessary accessories. As for the dynamic function, the frame must confer precise steering, good road holding and comfort, while working in conjunction with the rest of the rolling chassis.

1.2 SELECTION OF TYPE OF CHASSIS:

There are different types of motorcycle frames according to their basic structure. The types include backbone frame, perimeter frame, diamond frame, trellis frame, cradle frame. Each type has its advantages and disadvantages. The trellis frame structure was chosen because of its high structural efficiency. The Trellis frame is similar in its basic concept to the perimeter frame. This frame's primary objective is to connect the steering head with the swing-arm as directly as possible. The primary difference, however, is the way the two beams emanating from the steering head are constructed. Unlike the perimeter frame which utilizes aluminium beams, trellis frame uses a bunch of short sized steel or aluminium tubes welded together to form a trellis like structure. So, while the concept remains the same, trellis frame, in most cases manages to ace the perimeter frame in terms of rigidity, and light construction. Despite its simplicity, it's very effective and is the frame of choice for a whole bunch of bike makers. So, the best choice was to select a trellis frame for our motorcycle because of its major pros.

1.3 MATERIAL SELECTION:

The options available were AISI 1018, AISI 1020, AISI 4130 and other standard materials. Considering various features and forms of material available in the market, we decided to use AISI 4130 for the manufacturing of the chassis. The main factors for its selection were its medium cost but high stiffness to weight ratio, good weldability and easy availability. The ANSYS analysis (provided further in report) done in prior stages assisted us in determining the final shape and dimension of the material to be used. After overall consideration we finally decided to go with this dimension of the pipes.

Table 1.1: Dimensions of pipe

Sr. No	Designation	O.D.	Thickness
1.	Main Pipes	1 inch	2.6 mm
2.	Front Triangulation	¾ inch	2.5 mm
3.	Back Triangulation	¾ inch	1.3 mm

1.4 DESIGN MODEL OF CHASSIS

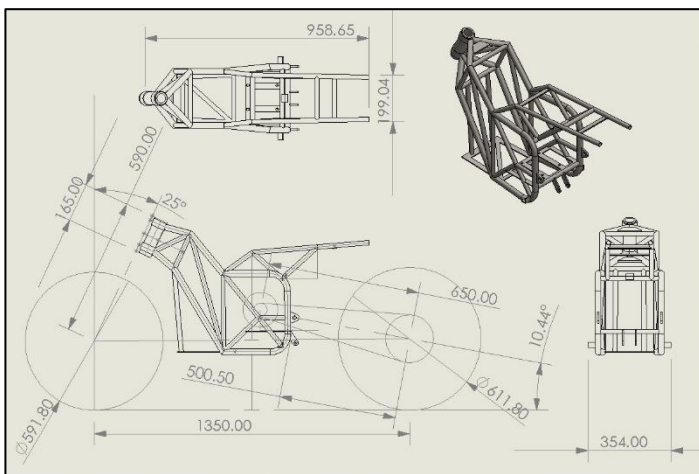

Figure 1.1: Chassis Draft with overall dimensions

The designed chassis consists of in all 47 members along with two welded plates. The overall length of the chassis is about 648.65mm measured parallel to road surface in the front plane, while the minimum and maximum width is 99.04 mm and 354 mm respectively. The overall length of the headtube is 165 mm with diameter 55 mm and thickness 7.5 mm. But to increase the strength of the chassis in front impact test, we have increased its thickness at the top and the bottom.

Like every other chassis, this was designed keeping in mind the placement of the components and suspension and steering points.

Given below are some of the properties of the selected material for the pipe.

Properties of AISI 4130	
Tensile strength	615 M Pa
Yield strength	460 M Pa
Poisson's ratio	0.27-0.3
Mass density	7850 kg/m ³
Elastic Modulus	190-210 G Pa

Table 1.2: Properties of AISI 4130



(a) Main Pipes

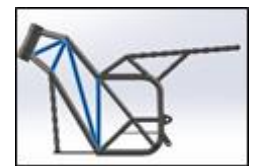

(b) Front Triangulation

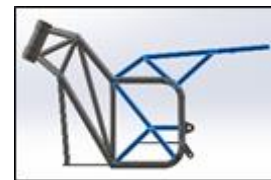

(c) Back Triangulation

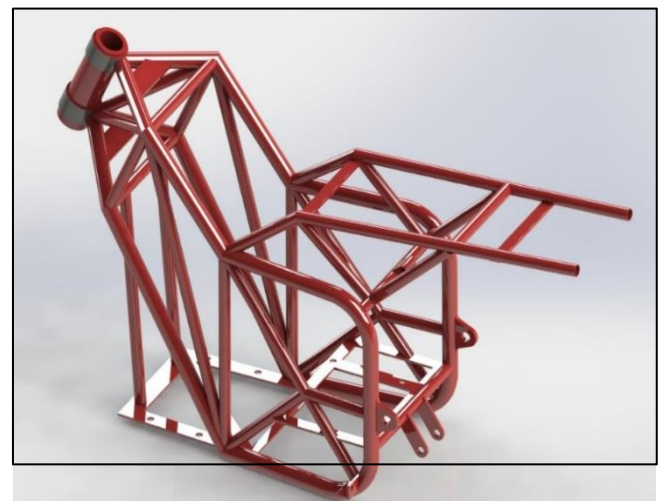

Figure 1.2: Isometric view of chassis model

The values of wheelbase, rake and trail by considering steering feasibility were assumed and calculated as 1350 mm, 25° and 92mm respectively. The swingarm and strut mounting points were decided by the suspension department and thus many chassis iterations were made and finally a most efficient one was chosen by conducting the analysis on ANSYS 19.2 and trying to keep the weight to the minimum. Also, the arrangement of the components to be placed in the chassis was supposed to be such that the center of gravity must be as low as possible so as to achieve stability.



Figure 1.3: Motorcycle Assembly

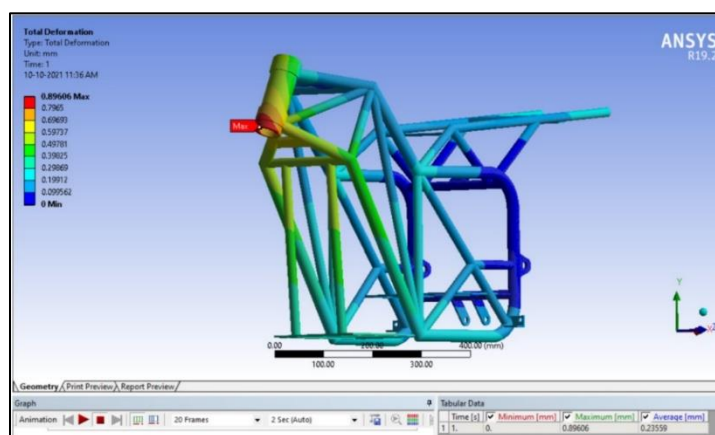

Figure 1.4: Total Deformation Front Impact

1.5 DESIGN CALCULATION AND ANALYSIS:

NOMENCLATURE:

- v = Final velocity of the impact (m/s)
- u = Initial velocity of the impact (m/s)
- a = Acceleration during impact (m/s²)
- F = Impact force (N)
- m = Mass of the bike + rider (kg)
- t = Impact duration (s)
- D = Outer diameter of pipe c/s (m)
- d = Inner diameter of pipe c/s (m)
- r = Mean radius of pipe c/s (m)
- E = Young's modulus of elasticity (N/m²)
- σ_y = Yield strength (N/m²)
- I = Moment of inertia of pipe (m⁴)

Calculation:

(1) Impact Force Calculation (F)

We know, $v = 0 \text{ m/s}$, $u = 12.5 \text{ m/s}$ (Avg speed of bike= 45 km/hr),
 $t = 0.257 \text{ sec}$, $\sigma_y = 460 \text{ MPa}$,
 $E = 210 \text{ G Pa}$, $m = 175 \text{ kg}$

$$\therefore v = u + at$$

$$0 = 12.5 + a(0.257)$$

$$\therefore a = 48.638 \text{ m/s}^2$$

$$\therefore F = ma$$

$$F = 175 \times 48.638$$

$$\therefore F = 8512 \text{ N}$$

2) Moment of inertia of pipe (I)

$$I = \pi/64 \times (D^4 - d^4)$$

$$= \pi/64 \times (0.0254^4 - 0.0202^4)$$

$$\therefore I = 1.22588 \times 10^{-8} \text{ m}^4$$

3) Bending strength calculation:

$$\text{Bending strength} = (\sigma_y \times I) / r$$

$$= (460 \times 10^6 \times 1.22588 \times 10^{-8}) / 0.0127$$

$$= 443.70 \text{ N - m}$$

ANALYSIS ON CHASSIS:

We performed analysis on ANSYS 19.2. Safety and strength are the most crucial parameters that are to be considered while analysing the chassis. To test the strength of the chassis we performed series of analysis. From the results obtained from above test, we decided the number of supporting and cross members to be added and selecting the material of circular pipe accordingly.

IMPACT ANALYSIS:

FRONT IMPACT ANALYSIS:

Force applied = 8512 N
 Body on which force applied = Headstock
 Constraints = Rear swing arm mounting point

Displacement: All degrees of freedom are constrained.

Load	8512 N
Max. Equivalent Stress	266.64 MPa
Max. deflection	0.896 mm
F.O.S.	1.7252

Table 1.3: Front Impact Analysis

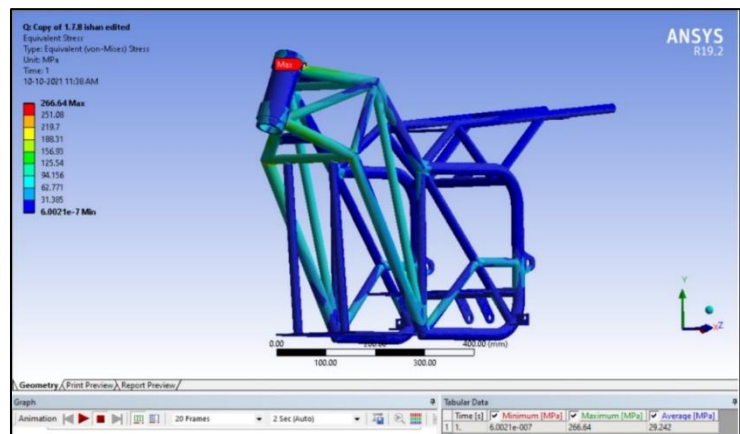

Figure 1.6: Equivalent Stress for Front Impact

BENDING STRESS ANALYSIS:

Bending of the seat mounting members occur due to the weight of the rider. Also, the mountings for the battery and motor bends due to their weight.

Considering the weight of the rider, luggage and the seat a load of 90 kg, weight of battery 21 Kg, weight of motor 10kg is applied for the bending stress analysis.

Max. Equivalent stress	28.445 MPa
Max. deflection	0.1812 mm
F.O.S.	15

Table 1.4: Bending Stress Analysis

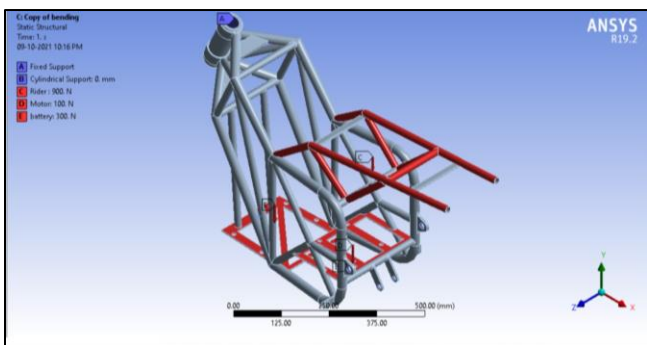

Figure 1.7: Application of loads and constraints

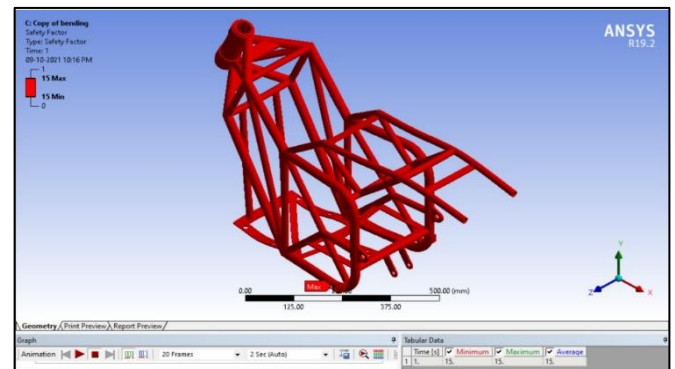

Figure 1.9: FOS for Bending

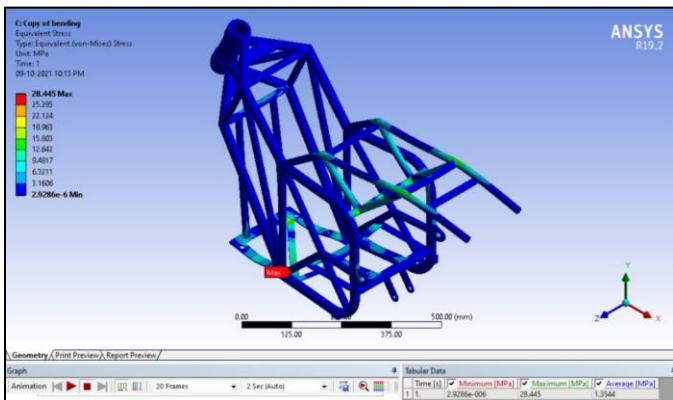

Figure 1.8: Equivalent Stress for Bending

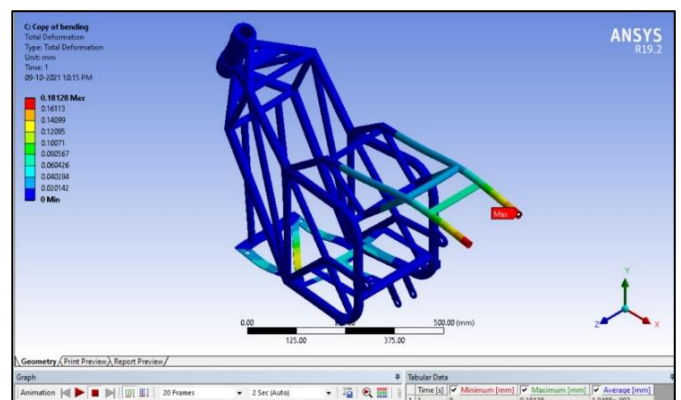

Figure 1.0: Total Deformation for Bending

2. MOTORCYCLE GEOMETRY

Motorcycles can be described using the following geometric parameters:

- the wheelbase, p
- the caster angle, ε
- the trail, a
- fork offset: perpendicular distance between the axis of the steering head and the center of the front wheel, d
- radius of the rear wheel, R_r
- radius of the front wheel, R_f
- radius of the rear tire cross section, t_r
- radius of the front tire cross section, t_f

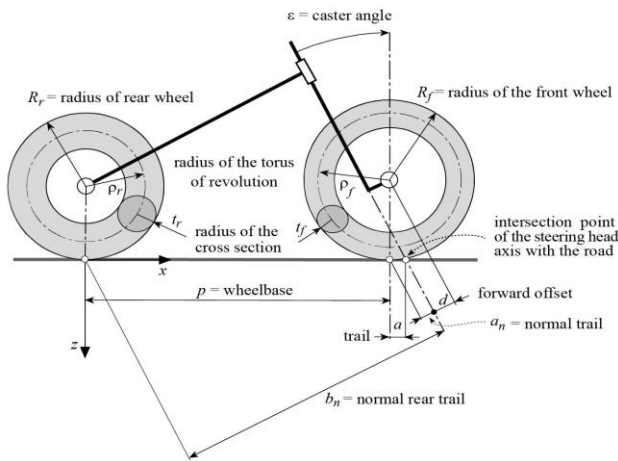

Figure 2.1: Motorcycle Geometry

The wheelbase p is the distance between the contact points of the tires on the road. The caster angle ε is the angle between the vertical axis and the rotation axis of the front section (the axis of the steering head). Trail is defined as the distance from the point at which the steering axis intersects the ground to the front tire's contact patch, while normal trail is defined as the perpendicular distance from the steering axis to the tire's contact patch. Both are dependent on rake, offset and front tire radius.

Together these parameters are important in defining the maneuverability of the motorcycle as perceived by the rider.

The value of the wheelbase varies according to the type of motorcycle. It ranges from 1200 mm in the case of small scooters to 1300 mm for light motorcycles (125 cc displacement) to 1350 mm for medium displacement motorcycles (250 cc) up to 1600 mm, and beyond, for touring motorcycles with greater displacement. In general, an increase in the wheelbase, assuming that the other parameters remain constant, leads to:

- an unfavourable increase in the flexional and torsional deformability of the frame. These parameters are very important for manoeuvrability (frames that are more deformable make the motorcycle less manoeuvrable),
- an unfavourable increase in the minimum curvature radius, since it makes it more difficult to turn on a path that has a small curvature radius,
- in order to turn, there must be an unfavourable increase in the torque applied to the handlebars,
- a favourable decrease in transferring the load between the two wheels during the acceleration and braking phases, with a resulting decrease in the pitching motion; this makes forward and rearward flip-over more difficult,
- a favourable reduction in the pitching movement generated by road unevenness,
- a favourable increase in the directional stability of the motorcycle.

The caster angle varies according to the type of motorcycle: from 19° (speedway) to 21-24° for competition or sport motorcycles, up to 27-34° for touring motorcycles. From a structural point of view, a very small angle causes notable stress on the fork during braking. Since the front fork is rather deformable, both by flexibility and torsional forces, small values of the angle will lead to greater stress and therefore greater deformations, which can cause dangerous vibrations in the front assembly (oscillation of the front assembly around the axis of the steering head, called wobble).

The value of the trail depends on the type of motorcycle and its wheelbase. It ranges from values of 75 to 90 mm in competition motorcycles to values of 90 to 100 mm in touring and sport motorcycles, up to values of 120 mm and beyond in purely touring motorcycles.

Some measurements of common commercial bikes is given below:

Wheelbase:

Splendor- 1270mm; Pulsar 150- 1345mm; Apache 160- 1365mm; Royal Enfield 350- 1395mm.

Caster Angle: Yamaha FZ- 26°

Trail:

Splendor- 89mm; Apache 160- 125.6mm; Yamaha FZ- 91mm

Considering all these aspects we have decided the following parameters:

Wheelbase- 1350mm

Caster Angle- 25°

Triple clamp offset- 41.80mm

Trail- to be calculated from formula

$$\text{Trail} = \frac{R_f \sin \theta - d}{\cos \theta}$$

$$\text{Trail} = \frac{295.9 \sin(25^\circ) - 41.80}{\cos(25^\circ)}$$

$$\text{Trail} = 91.86 \text{ mm}$$

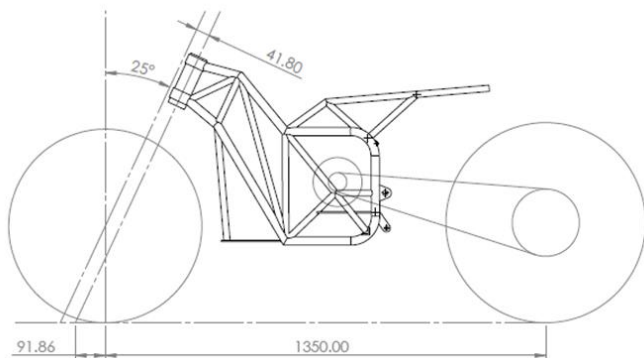

Figure 2.2: Line Diagram with Geometry

3. SUSPENSION

3.1 INTRODUCTION:

There are 3 main reasons for use of suspension in a motorcycle:

- Minimize harshness.
- Maximize traction.
- Improve control.

Suspension is nothing but a spring which helps to increase the comfort and safety of the ride. The spring is connected to a damper.

A perfect ride produced by the perfect suspension starts with maximum traction. It's also firm with good resistance to bottoming and great "feel" for the road, yet it is plush and comfortable at the same time.

3.2 FORCES IN SUSPENSION:

There are three distinct types of forces involved in suspension action: spring, damping, and frictional.

The key point to remember about spring force is that it is dependent only on its position regarding the overall travel of the suspension, meaning the distance the spring is compressed. It is not affected by how fast the suspension is compressing or rebounding.

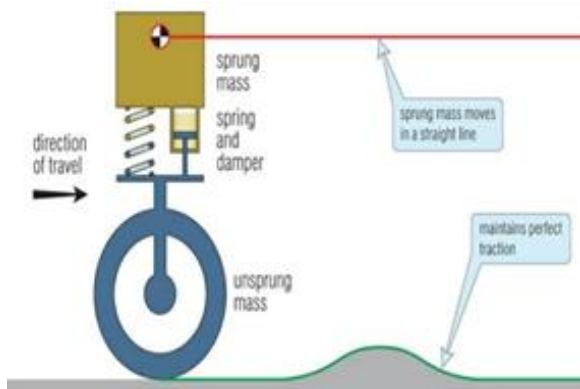

Figure 3.1: Sprung mass and unsprung mass

3.3 ENERGY CONVERSIONS IN A SUSPENSION SYSTEM:

- The spring converts the K.E. into P.E.
- A damper converts the mechanical energy into heat energy,

3.4 TYPES OF SPRING:



Figure 3.2: Types of spring

- Straight Rate Spring:

It maintains a constant rate through its travel. (The coils are evenly spaced)

- Dual Rate Spring:

It has two different coils spacing along its length.

- True Progressive Spring:

It has coils that starts together and then are placed progressively further apart with each successive coil.

3.5 .FRONT SUSPENSION:

3.5.1 TELESCOPIC FORKS:

Most motorcycles today use telescopic forks for the front suspension. The forks can be most easily understood as simply large hydraulic shock absorbers with internal coil springs.

3.5.2 TYPES OF TELESCOPIC FORKS:

- Conventional forks:

On conventional telescopic forks, the lower portion or fork bodies, slide up and down the fork tubes.

- Upside down forks:

Upside-down (USD) forks, also known as inverted forks, are installed inverted compared to conventional telescopic forks. The slider bodies are at the top, fixed in the triple clamps, and the stanchion tubes are at the bottom, fixed to the axle.

CONVENTIONAL	UPSIDE DOWN
They are cheaper in cost compared to inverted telescopic fork.	It decreases the unsprung weight of the motorcycle
No risk of losing damp oil due to failure of oil seal.	It increases torsional stiffness, which can improve handling.

Table 4.1

Factors	HYDRAULLIC	NITROGEN
Cost	Cheap	Costly
Range	Good for short range travel (100- 200km).	Works same as hydraulic for short range travel but has an edge over it for long distances

Table 4.2

3.5.4 SELECTION OF TELESCOPIC FORKS:

The relationship of 65-35% best suited our requirements, So we proceeded with the forks of Bajaj Discover 125 ST.

- As our prototype is designed for commercial purpose, we have decided conventional installation of forks since they are easy to install and they possess other advantages over USD installation as mentioned earlier.

3.6. REAR SUSPENSION:

3.6.1 TYPES OF REAR SUSPENSION:

- MONO-SHOCK**

On a motorcycle with a single shock absorber rear suspension, a single shock absorber connects the rear swingarm to the motorcycle's frame. Typically, this lone shock absorber is in front of the rear wheel and uses a linkage to connect to the swing arm. Such linkages are frequently designed to give a rising rate of damping for the rear.

- TWIN-SHOCK**

Twin shock refers to motorcycles that have two shock absorbers. In most cases, these two shock absorbers are installed on the side of the rear wheel.

The performance of Mono-shock suspension is vastly superior to Dual-shock suspension, for this reason we have decided to install Mono-shock suspension in our design.

3.6.2 COMPONENTS OF REAR SUSPENSION:

- Swing-Arm**

A swingarm, originally known as a swing fork or pivoted fork, is the main component of the rear suspension of most modern motorcycles. It is used to hold the rear axle firmly, while pivoting vertically, to allow the suspension to absorb bumps in the road.

- Strut**

The strut consists of two parts i.e. spring and dampers. The spring compresses due to these forces, moving the wheel upwards, when the force acting on the wheel becomes less than the force of the spring, the wheel begins to move downward.

A shock absorber or damper is a mechanical or hydraulic device designed to absorb and damp shock impulses. It does this by converting the kinetic energy of the shock into another form of energy (typically heat) which is then dissipated.

- Linkages**

Linkages allow for a sufficiently progressive action of the rear suspension to have compliance and traction over rough terrain with excellent bottoming resistance. A linkage type shock setup has the following benefits:

-Lower center of gravity

-Better mass centralization

-Customizable spring and damping rate profiles, which allows for both initial bump compliance and bottom-out

resistance

-Allows the use of common linear-rate springs

CALCULATION OF SWINGARM ANGLE:

One of the methods of calculating the swingarm angle is through geometry of motorcycle. 100% anti squat means there is exact amount of vertical force that is required for the rear suspension to move freely without lifting or squatting.

If the anti squat is greater than 100% and we accelerated the motorcycle hard enough, the front end would lift off the ground and wheelie over. We see anti squat greater than 100% generally in dirt bikes and some sport bikes.

If the anti squat is lesser than 100%, there is not enough vertical force. So when the motorcycle is accelerated, the rear suspension compresses (squats).

GENERAL PROCEDURE:

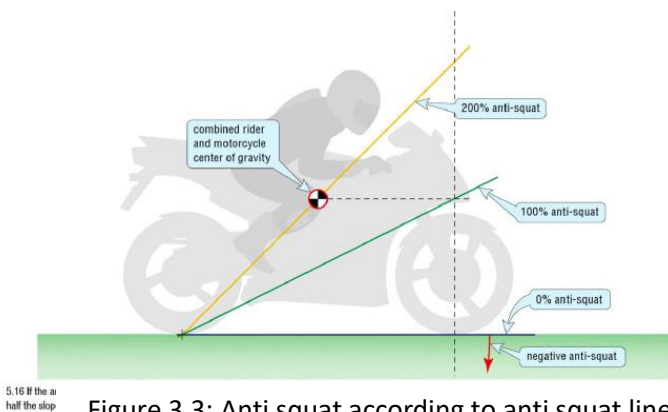

Figure 3.3: Anti squat according to anti squat line

Consider the lines shown in figure, one along the top chain run and the other line is drawn from the rear tire's contact patch and passing through the CG. This line is the 200% anti squat. Now, draw a line having half slope (not half angle) of the 200% anti squat line from the rear tire's contact patch to intersect the line along the top chain run. Draw a line passing through this point of intersection and the axle. The swingarm must lie on this line. The inclination of swingarm as per geometry is 10.86° .

Using this angle and length of swing-arm, the mounting point of swing-arm pivot point was noted on the chassis.

This method is applicable only if the center of gravity can be assumed in the middle of the motorcycle.

3.8 DESIGNING OF SWINGARM:

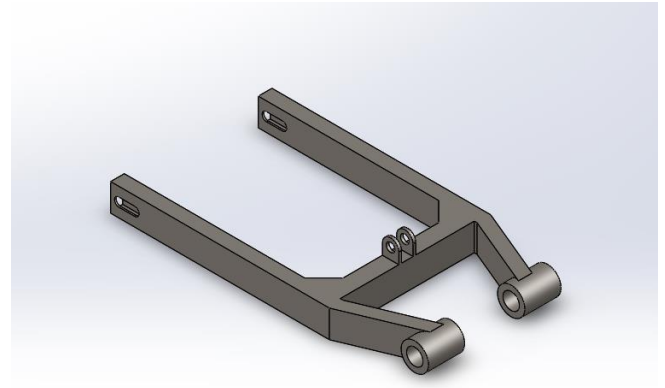

Figure 3.4: Design of Swing arm

The motorcycle Swingarm is a key component of the rear suspension of a motorcycle. It connects the rear wheel of the motorcycle to the main chassis and it regulates the rear wheel-road interactions via the linkages and shock absorber.

Two basic designs exist, namely the single-sided and double-sided swing arms.

H-type swing-arm is easy to manufacture and install as compared to single sided swing-arm.

3.8.1 Designing Procedure:

- CAD modelling of swing-arm was done using **SOLIDWORKS** software.
- Weight of swingarm designed in CAD is 5.9 kg.
- Consider weight factor of hollow **AISI 4130 steel** rectangular pipe of cross-section "**25mm x 50mm**" & thickness **3mm** is used

3.8.2 Material Selection

- The material used in this swing-arm is Steel AISI 4130.
- Advantages of using this material is:
 1. It is easily available in the market.
 2. Good machinability

3. Good mechanical properties
 - Mechanical properties – (Table 4.4)

Sr. No.	Properties	Value
1	Tensile strength (MPa)	560
2	Yield strength (MPa)	460
3	Elastic Modulus (GPa)	200
4	Poisson's ratio	0.26
5	BHN	217

ANALYSIS:

FEA is performed on the final design of the swing-arm. ANSYS 2020 R1 software is used for analysis and simulation of the swing-arm. The meshing used was of 3 mm size having average skewness of 0.3.

Four types of analysis were performed viz.

- Force analysis
- Torsional analysis
- Lateral analysis
- Cornering forces analysis

1. Force analysis:

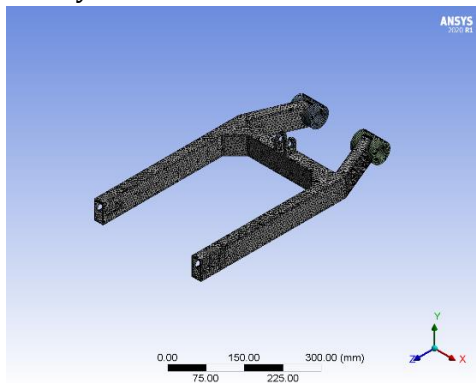

- The swing arm has fixed support attached to the chassis and other end has the bearings in which the rear wheel axle is rotating.
- The spring dampers are mounted through linkages on the welded plate.

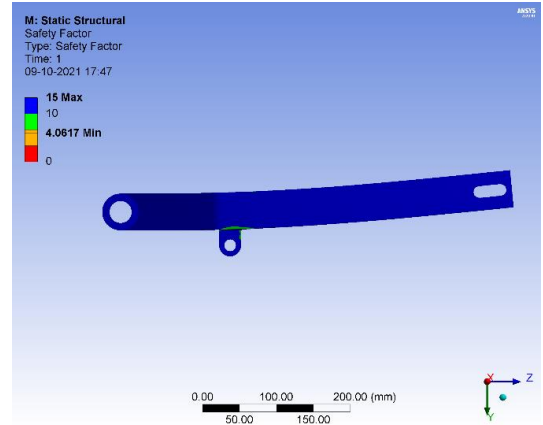

Figure 3.5: FOS for Force

- During running conditions, due to bumps the force is exerted on the rear wheel axle and the damper mounting.
 - The max. force generated on dampers is **4500 N** and wheel axle is **1500 N**.
 - The stresses induced in the swing-arm is well below the yield strength of the material.
 - Hence the component is safe to use based on the analysis during extreme conditions.
 - During safety test, the minimum factor of safety obtained is **4.0617**.
- This shows that the swing-arm is safe to use under extreme conditions.

2. Torsional Analysis:

- Torsional analysis is done considering the cornering condition.
- The force of **1500 N** is applied based on the calculations.
- Torsional analysis is shown below to find the **Total Max. Deformation** of the swing-arm during cornering condition.

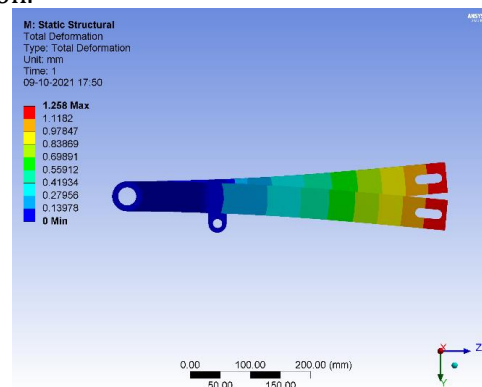

Figure 3.6: Total Deformation for Torsional Analysis

$$\text{Torsional stiffness} = \frac{\text{Force Applied}}{\text{Total deformation}}$$

$$\text{Therefore, torsional stiffness} = \frac{1500}{1.258} = 1.19 \text{ kN/mm}$$

This value lies in the ideal range of 1 to 2 kN/mm as mentioned in Vittore Cossalter.

3. Lateral Analysis:

- Lateral analysis is done to calculate lateral stiffness of the swingarm.
- Forces of **2000 N** was applied in opposite direction on the rear end of the swingarm.
- Lateral analysis is shown below to find the **Total Max. Deformation** of the swing-arm.

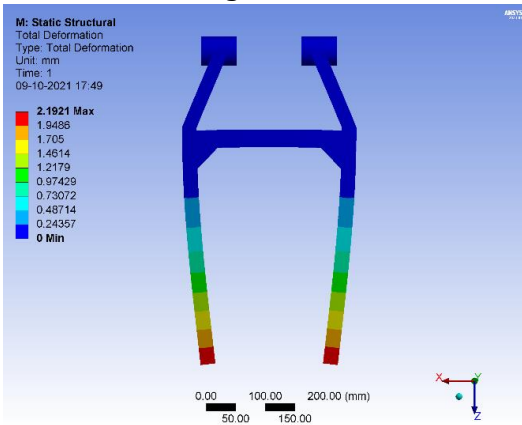

Figure 3.7: Total Deformation for Lateral Analysis

- Lateral stiffness is calculated as force applied/total deformation

$$\text{Therefore, lateral stiffness} = \frac{2000}{2.1921} = 0.912 \text{ kN/mm}$$

This value lies in the ideal range of 0.8 to 1.6 kN/mm as mentioned in Vittore Cossalter.

4. Cornering Force Analysis:

- During cornering, different components are subjected to variation in loads in magnitude as well as direction. In case of swing arm, high lateral forces act in unbalanced state. The magnitude of variation depends upon the angle of inclination and the vehicle speed.
- Loads and boundary conditions- It is assumed that 20% more load are transferred to the inner side during cornering. Thus, the inner side beam will have 70% of the total weight and remaining

30% on the outer side beam. if we consider a maximum cornering angle of 50° and divide the forces into vertical and horizontal components.

There will be torsional and lateral imbalance on the middle part

So, 70% of weight,

$$F_{\text{max}} = 0.7 \times m \times g = 0.7 \times 180 \times 9.81 = 1236.06 \text{ N}$$

And remaining 30%

$$F_{\text{min}} = 0.3 \times m \times g = 0.3 \times 180 \times 9.81 = 529.74 \text{ N}$$

Horizontal components (acting as lateral imbalance):

$$F_{iH} = F_{\text{max}} \cos \theta = 1236.06 \times \cos 50^\circ = 794.52 \text{ N}$$

$$F_{oH} = F_{\text{min}} \cos \theta = 529.74 \times \cos 50^\circ = 340.51 \text{ N}$$

Vertical components (acting as torsional imbalance):

$$F_{iV} = F_{\text{max}} \sin \theta = 1236.06 \times \sin 50^\circ = 946.87 \text{ N}$$

$$F_{oV} = F_{\text{min}} \sin \theta = 529.74 \times \sin 50^\circ = 405.8 \text{ N}$$

Following safety factor was obtained from the above analysis

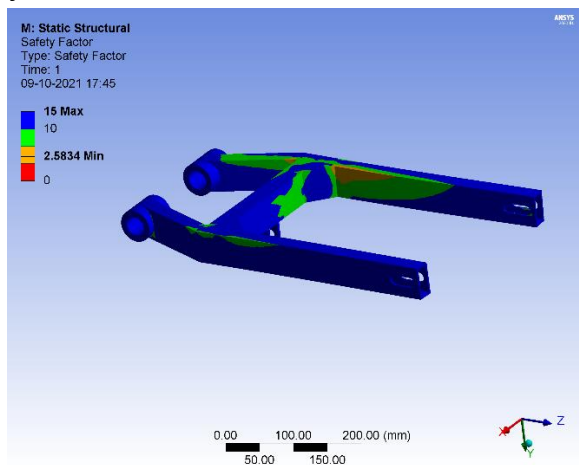

Figure 3.8: FOS for Cornering

- During safety test, the minimum factor of safety obtained is **2.5834**.
- This shows that the swing-arm is safe to use under extreme cornering conditions.

3.9. LINKAGES

For our design, we desired to create a progressive system, meaning the suspension

becomes increasingly harder to compress as the wheel moves upward. In order to ensure our prospective design achieved this, we analyzed how the leverage ratios changed throughout the range of motion in our design. These values then allowed us to calculate the relationship between the wheel rate and wheel displacement. The principal that the wheel rate is equal to the spring rate divided by the square of the Velocity Ratio (VR) applies to all suspension formats. We calculated the VR for our design by using the equation below.

$$VR = \frac{L_w}{L_l} \times \frac{L_2}{L_1}$$

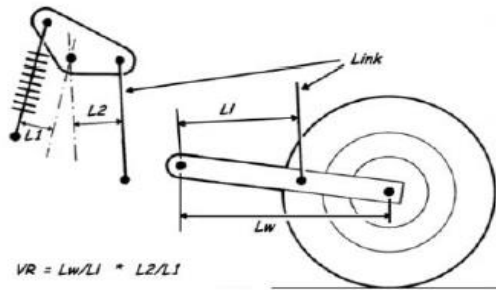

With VR calculated, we were able to calculate the effective wheel rate using the equations below.

$$\text{Wheel rate} = \frac{\text{spring rate}}{VR^2}$$

$$\text{Wheel Force} = \frac{\text{spring force}}{VR}$$

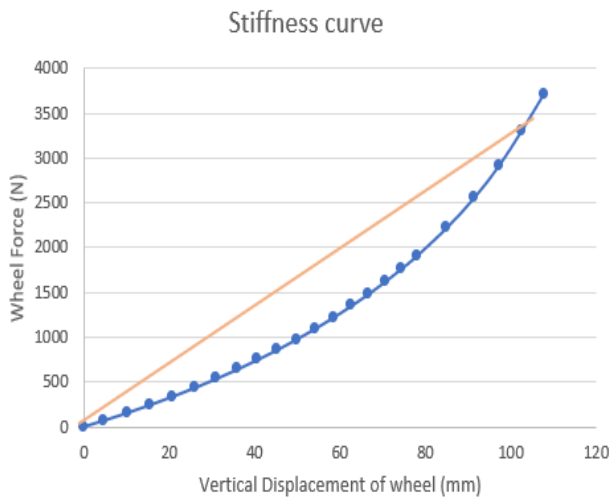
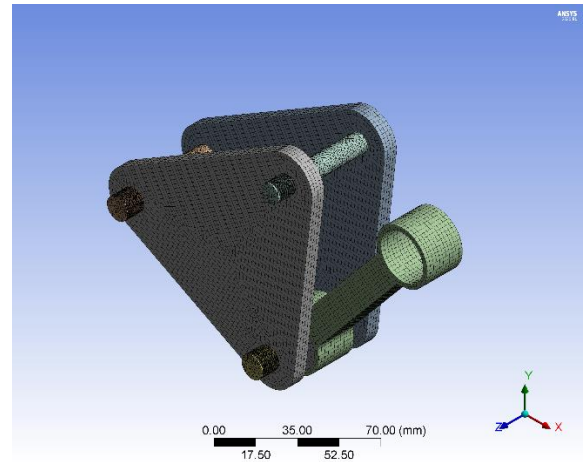

Chart-1: Stiffness curve chart

Linkages Analysis:

FEA is performed on the final design of the Linkages.

ANSYS 2020 R1 software is used for analysis and simulation of the linkages. The meshing used was of 2 mm size having average skewness of 0.25.



The force of 4500 N i.e. the maximum spring force was applied on the bolt where the shock absorber is mounted. The bolt which is to be mounted on chassis has been given fixed support and the free end of the dog bone rod was given fixed support as there won't be any relative motion between them. The other end of the rod was given frictional contact ($\mu=0.1$) with the bearing.

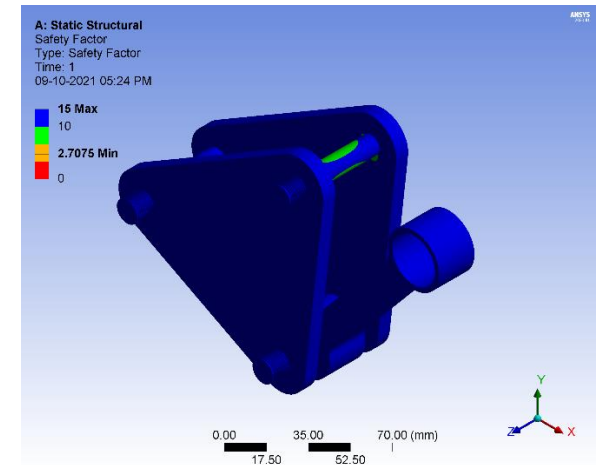

Figure 3.9: FOS For Force

- The minimum factor of safety obtained is 2.7075 .
- This shows that the linkages is safe to use under extreme conditions.

4. BRAKES

4.1. INTRODUCTION:

In most cases the brake engineer has to design the braking system such that certain objectives are achieved.

- There should be two independent disc brake systems in the vehicle (in both front and rear) to ensure braking even during failure of one of the system.
- Disc brakes should be of hydraulic actuation operated through mechanical linkage, wire actuation is strictly prohibited.
- The braking torque generated should be greater than the required braking torque. Nevertheless, it should not be such that the vehicle loses contact with the ground.
- The brake light (Red) must be used for showing the brake's actuation for both front and rear, even during the off state of bike.
- High braking efficiency is required as on many occasions the brakes are required to stop the vehicle in emergency.
- Higher braking efficiency can cause wear and tear of tyre, also it leads to risk of losing control of the vehicle. Hence, braking efficiency of order 50-60% helps to stop within reasonable distance.

4.2. DESIGN OF BRAKING SYSTEM

- We initiated the designing of an effective Hydraulic Disc Braking System by considering the above mentioned factors.
- Our hydraulic brake system is controlled by a
 1. Lever (right) for front braking action, in line with one separate master cylinders.
 2. Pedal (near leg rest on the right side of vehicle) for rear braking action.

Inter-lock, in case one fails the other will still be operable.

Sr no.	Parameters	Value
1.	m	180 kg
2.	g	9.81 m/s ²
3.	L(wheel base)	1350mm

4.	x(distance of C.G. from rear tyre)	675mm
5.	h	550mm
6.	RAmax(reaction at A)	1236.78N
7.	RBmax(reaction at B)	529.02N
8.	fA (frictional force at A)	2333.33N
9.	fB (frictional force at B)	3024N
10.	Radius of front and rear tyre	rA=300mm rB=310mm
11.	Front Disc Diameter(DA)	0.230m
12.	Rear Disc Diameter(DB)	0.230m
13.	Front caliper Piston diameter	0.025m
14.	Rear caliper Piston diameter	0.03m
15.	Coefficient of friction($\mu_{brake\ pad}$)	0.4
16.	Coefficient of friction(μ_{tyre})	0.4
17.	Master cylinder bore diameter	0.015m
18.	Master cylinder bore Area	1.767x10 ⁻⁴ m ²
19.	Pedal ratio(L2:L1)	6:1

4.3. CALIPER SELECTION:

- As per our calculations, the calipers were selected due to their small size giving acceptable values of clearance, while maintaining good braking capability.
- Dual piston floating type caliper was selected for front while single piston floating type was used for rear.

4.4. MASTER CYLINDER SELECTION:

- Each Master cylinder of bore diameter 0.011m forms an individual hydraulic braking circuit such that maximum pressure is generated with optimum travel.

4.5. CALCULATIONS:

$$\frac{L_2}{L_1} = 6 \text{ (Pedal Ratio)}$$

$$F_{m\text{front}} = 100 \times 6 = 600N$$

$$F_{m\text{rear}} = 90 \times 6 = 540N$$

Now,

$$P_m = P_c$$

$$\frac{F_m}{A_m} = \frac{F_c}{2Ac} \text{ (Since there are two pistons in master cylinder and one in caliper)}$$

For front,

$$F_c = F_{mF} \times \frac{2Ac}{Am}$$

$$= 600 \times 2 \times \frac{25^2}{15^2} \text{ (Ratio of diameter)}$$

$$= 3333.33N$$

Therefore, clamped force = $2F_c = 6666.67N$

$$F_{\text{friction } F} = 2 F_c \mu_{BP} \text{ (Friction between rotor and pad)}$$

$$= 6666.67 \times 0.35$$

$$= 2333.33N$$

$$\text{Rotor radius}(F) = 115\text{mm}$$

$$r_e = 0.9 \times 115 = 103.5 \text{ mm}$$

Now,

$$\tau_{\text{gen } F} = r_e \times F_{\text{friction } F}$$

$$= 241499.65Nmm$$

Assuming $\tau_{\text{gen}} = \tau_{\text{required}}$

$$F_{\text{tire}} \times R_{\text{tire}} = 241499.65$$

$$\text{Therefore, } F_{\text{tire}} = \frac{241499.65}{295.9}$$

$$= 816.15N$$

For rear,

$$F_c = F_{mR} \times \frac{2Ac}{Am}$$

$$= 540 \times 2 \times \frac{30^2}{15^2} \text{ (Ratio of diameter)}$$

$$= 4320N$$

Therefore, clamped force = $2F_c = 8640N$

Figure 4.1: Thermal Analysis of Rotor Disk

$$F_{\text{fric}} = 2$$

$$F_c \mu_{BP} \text{ (Friction between rotor and brake pad)}$$

$$= 8640 \times 0.35$$

$$= 3024N$$

$$\text{Rotor radius}(R) = 115\text{mm}$$

$$r_e = 0.9 \times 115 = 103.5 \text{ mm}$$

$$\text{Now, } \tau_{\text{gen } F} = r_e \times F_{\text{friction } R}$$

$$= 312984Nmm$$

Assuming $\tau_{\text{gen}} = \tau_{\text{required}}$

$$F_{\text{tire}} \times R_{\text{tire}} = 312984$$

$$\text{Therefore, } F_{\text{tire}} = \frac{312984}{305.9}$$

$$= 1023.15N$$

$$a(\text{deceleration}) = \frac{\sum F_{\text{tire}}}{m} = \frac{1839.2}{180}$$

$$= 10.218\text{m/s}^2$$

Taking $u(\text{top speed}) = 83.89 \text{ km/h} = 23.3\text{m/s}$

$$\text{Stopping time}(t) = \frac{v-u}{a} = \frac{0-23.3}{-10.218}$$

$$= 2.28\text{sec}$$

$$\text{Stopping distance}(s) = \frac{u^2}{2a} = \frac{23.3^2}{2 \times 10.218}$$

$$= 26.56\text{m}$$

• BRAKE LINES :

We have used braided stainless steel brake lines as they are flexible hoses fitted to a hydraulic brake system. The intent of rubber hoses was to improve brake system and effectiveness and longevity through near elimination of hose expansion.

• THE ROTOR:

It serves as primary heat sink in the breaking system , it is functional responsibility of the rotor to generate retarding torque as a function of brake pad friction force.

$$T_r = F_{\text{friction}} * R_{\text{effective}}$$

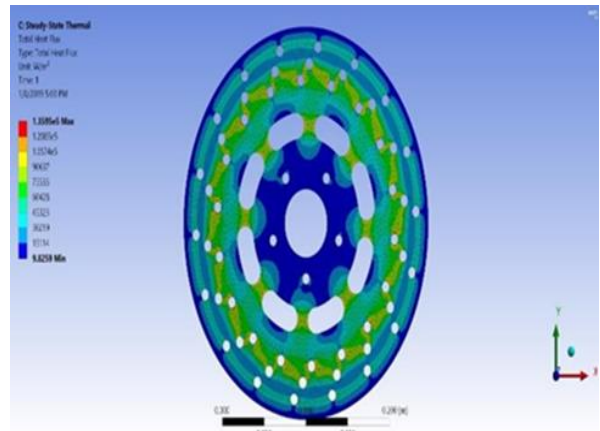

THERMAL ANALYSIS:

Kinetic Energy = $0.5 \times mv^2$

Front wheel

$v = r * \omega = 4.33 \text{ m/s}^2$

KE = 1570.02 J

Sr. No	PARAMETER	VALUE
1.	Front Disc diameter	0.230m
2.	Rear Disc diameter	0.230m
3.	Thickness of rotor	0.004m
4.	Brake disc thickness limit	0.0035m
5.	Brake disc thickness limit	0.0001m
6.	Brake pad lining thickness (Outer limit)	0.0053m
7.	Brake pad lining thickness (inner limit)	0.0008m

Total KE = Heat generated during braking Rubbing surface area (front) = $31 \times 10^{-3} \text{m}^2$

Heat flux = Heat generated/sec/rubbing area
 = $50645.79 \text{watts/m}^2$

Heat flux on the front wheel = $50645.79 \text{watts/m}^2$
 During 4 seconds of braking = 12661.44watts/m

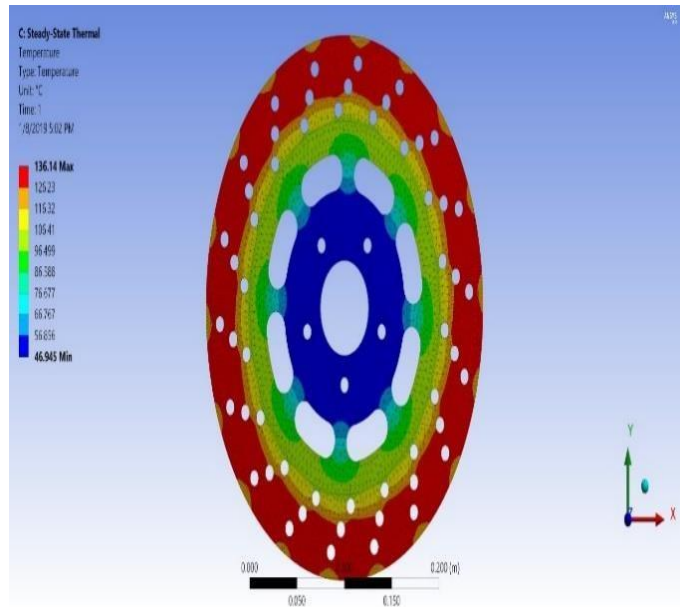

5. TRANSMISSION SYSTEM

5.1. INTRODUCTION:

The transmission system of the bike is a simple mechanism where the power is developed by the motor and later its transmitted to the Rear sprocket attached to the driving wheel.

There are 3 different types of transmission in bikes:

- Chain drive
- Belt drive
- Shaft driven

Chain drive has very low power loss of 3% as compared to belt (9%) and shaft

drive (25%). Chain drive is economical to manufacture and less in weight. it is indeed stronger and can take lot of stress. Chain drive has very low replacement cost whereas replacement cost of belt & shaft is very high. Hence, we have decided to use **chain** drive as our drive.

Components of chain drive are as follows:

- Driving sprocket
- Driven sprocket
- Chain.

5.2. GENERAL SYSTEM ANALYSIS:

$$\text{Power} = \tau \times W$$

$$= 7.5 \times \left(\frac{3000 \times 2\pi}{60}\right)$$

$$\text{Power} = \mathbf{2356.194W}$$

Where τ is torque and W is angular velocity

$$\tau = F \times r$$

$$F = \left(\frac{7.5}{0.37}\right) \times 4.7 = \mathbf{113.09N}$$

where F is force on wheels

r = wheel radius

$$\text{Gear ratio} = \frac{N1}{N2} = \frac{T2}{T1}$$

Where,

$N1$ = R.P.M of motor

$N2$ = R.P.M of wheel

$T1$ = Number of teeth of sprocket on motor= **10**

$T2$ = Number of teeth of sprocket on wheel= **39**

5.3. DRIVING SPROCKET:

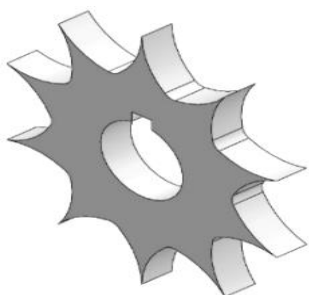

Figure 5.1: Front sprocket

It is used to transmit the power generated by motor to the driven sprocket which in turn rotates the wheels. The driving sprocket is designed to withstand the shear stress generated and transmit the torque efficiently to increase torque transmitted efficiency capacity and thus, increasing the overall acceleration, we have chosen the number of teeth on the driving sprocket to be ten **(10)**.

It is attached to the shaft in the motor which rotates at approx. 3000rpm and the material used can withstand the stress which omits the fear of any damages.

Hence the final drive ratio (FDR) is 3.9

CALCULATIONS OF DRIVING SPROCKET:

$$\text{Pitch}(p) = 12.7\text{mm}$$

$$\text{Number of teeth on driving sprocket } t=10$$

$$\text{Let addendum circle diameter} = da$$

$$\text{Dedendum circle diameter} = dd$$

$$\text{Pitch circle diameter (PCD)}= d$$

$$d = p \operatorname{cosec}\left(\frac{180}{t}\right)$$

$$= 12.7 \operatorname{cosec}\left(\frac{180}{10}\right)$$

$$= \mathbf{41.098\text{mm}}$$

$$\text{Addendum } (a) = \left(\frac{1}{p}\right) = 0.787$$

$$\text{Addendum circle diameter} =$$

$$da = \text{PCD} + 2a$$

$$= 41.098 + 2(0.787)$$

$$= \mathbf{56.838\text{mm}}$$

$$\text{Dedendum } (d) = \left(\frac{1.25}{p}\right) = 0.984$$

$$\text{Dedendum circle diameter} =$$

$$dd = \text{PCD} - 2d$$

$$= 41.098 - 2(0.984)$$

$$= \mathbf{21.418\text{mm}}$$

5.4. DRIVEN SPROCKET:



Figure 5.2: Rear sprocket
Sprockets are most made from

steel to increase their endurance is aluminium is sometimes chosen for racing in rear sprocket as it is lighter, but it wears more quickly than steel. The rear sprocket usually can have 28 to 60 teeth. Sprocket should be properly tightened by nuts and bolts with differential outer housing. The power is transmitted through sprocket to differential stub axle to half axle and wheel. We choose 39 teeth driven sprocket and 10 teeth driving sprocket giving us torque driving sprocket giving us torque multiplication factor or final drive ratio as 3.9 for designing of driving sprocket It is necessary to calculate pitch circle diameter by finding PCD, we can find the other parameter.

The centre-to-centre distance of two sprockets is 65cm.

CALCULATIONS:

Pitch = 12.7mm

Number of teeth on driven sprocket t=40

Let addendum circle diameter = da

Dedendum circle diameter = dd

Pitch circle diameter (PCD)= d

$$d = p \operatorname{cosec}\left(\frac{180}{t}\right)$$

$$= 12.7 \operatorname{cosec}\left(\frac{180}{39}\right)$$

=157.8mm

Addendum (a)

$$a = \left(\frac{1}{p}\right) = 0.787$$

Addendum circle diameter =

$$da = \text{PCD} + 2a$$

$$= 157.8 + 2(0.787)$$

=173.54mm

$$\text{Dedendum (d)} = \left(\frac{1.25}{p}\right) = 0.984$$

Dedendum circle diameter =

$$dd = \text{PCD} - 2d$$

$$= 157.8 - 2(0.984)$$

=138.20mm

CHAIN ANALYSIS:

Chain length in pitches

$$L = \left(\frac{2c}{p}\right) + \left(N + \frac{n}{2}\right) + \frac{p(N - \frac{n}{2})}{c}$$

$$L = \left(\frac{2 \times 650}{12.7}\right) + \left(39 + \frac{10}{2}\right) + \frac{12.7(39 - \frac{10}{2})}{650}$$

L=1470.24mm

☑ Chain Length (NUMBER OF LINKS)

$$Ln = 2\left(\frac{a}{p}\right) + \left(\frac{T1+T2}{2}\right) + \left(\frac{T2-T1}{2}\right)^2 \times \left(\frac{p}{a}\right)$$

$$= 2\left(\frac{649}{12.7}\right) + \left(\frac{39+10}{2}\right) + \left(\frac{39-10}{2\pi}\right)^2 \times \left(\frac{12.7}{649}\right)$$

=129.32~130 links

Chain efficiency of a chain drive system depends on the distance between centres of the sprocket which in turn depends on chain angle.

Hence, by calculations and analysis the preferred chain angle is approx. 5 degrees to give us the optimum chain efficiency where,

Chain angle =

difference between radius of sprockets

distance between the centre of sprockets

In the ideal case in chain drive sprocket when one side of chain is tight, and the other side of chain is slack, centrifugal force can be

neglected.

5.5. SPROCKET ANALYSIS:

FRONT SPROCKET

TOTAL DEFORMATION TEST

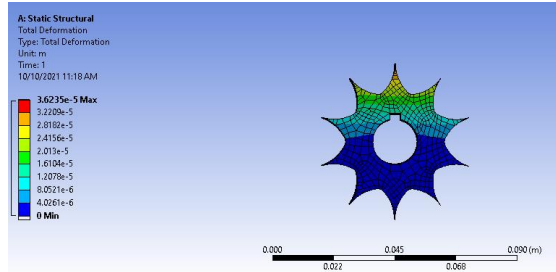

VON-MISSES STRESS TEST

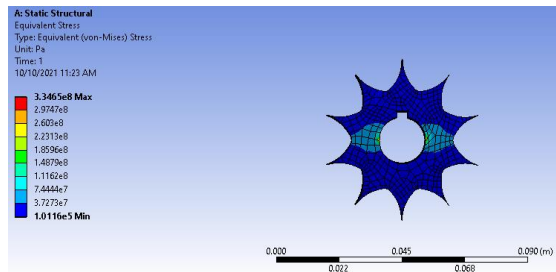

EQUIVALENT ELASTIC STRAIN TEST

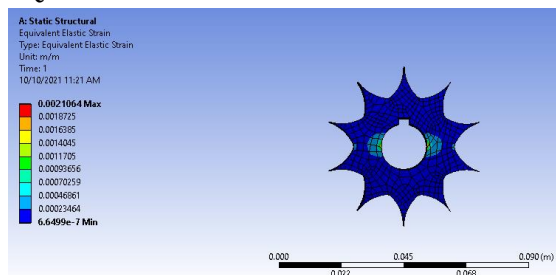

MAXIMUM PRINCIPAL STRESS TEST

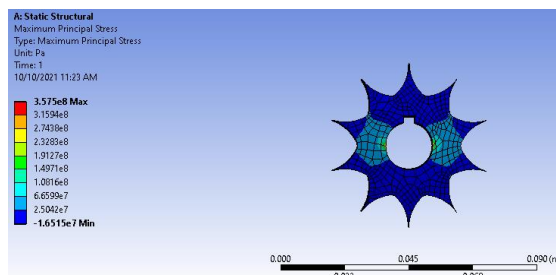

REAR SPROCKET

TOTAL DEFORMATION TEST

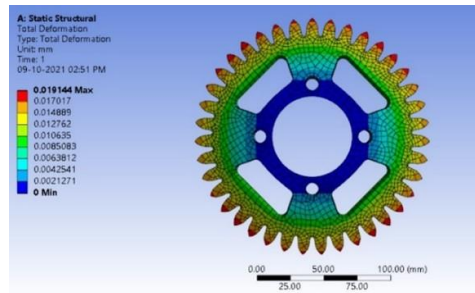

VON-MISSES STRESS TEST

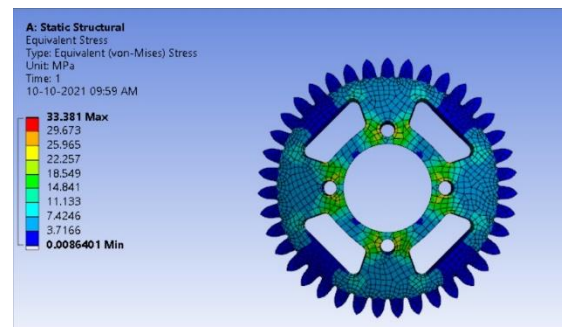

EQUIVALENT ELASTIC STRAIN TEST

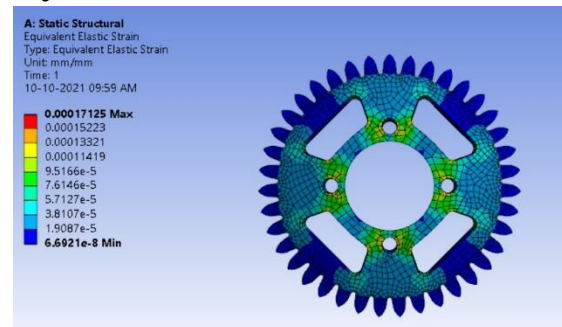

MAXIMUM PRINCIPAL STRESS TEST

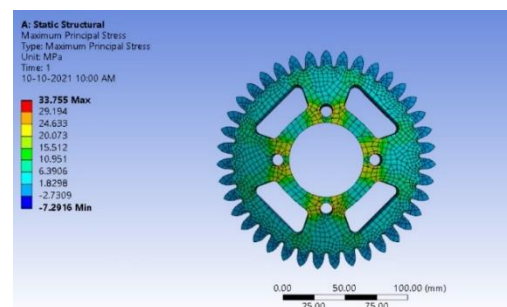

6. MOTOR AND BATTERY

6.1. TRACTIVE SYSTEM REPORT

Selected Motor: BLDC Motor

Reasons for selecting BLDC Motor:

BLDC Motors are selected for our vehicle due to the following advantages that they have over conventionally employed Brushed Motors

- High torque to weight ratio
- Lack of brushes and a physical commutator eliminates the problem of wear and tear of brushes, sparking is avoided, and frictional losses are minimized. Operational reliability is thus enhanced greatly and maintenance is reduced.
- Low electromagnetic interference due to absence of brushes.
- Effective cooling is possible.
- Direction change (Zero crossings) can be tackled more effectively and safely.

Calculations for motor Requirements:

We first consider some design values as constraints and evaluate the required performance characteristics of the vehicle. The design constraints will help us to determine the requirements of the Motor power and Torque characteristics to be used.

The output of the motor depends on the efficiency of the motor, weight of the vehicle and energy provided by the battery. The output torque and speed of the vehicle required with the above design constraints can be calculated as follows;

Calculation of the angular velocity () of wheels:

Linear velocity = 45 kmph

$$= 45 \times \frac{5}{18} \text{ m/s}$$

$$= 12.5 \text{ m/s}$$

Angular Velocity = Linear Velocity/Radius

$$= \frac{12.5}{0.3}$$

$$= 41.67 \text{ rad/s}$$

If total weight of the vehicle is 175kg (with driver),

Peak Torque =

(Mass of vehicle) ×

Acceleration due to gravity × Wheel Radius × Slope %

$$= 175 \times 9.81 \times 0.3 \times 0.1$$

Peak Torque = 51.5025 N – m

Peak Power = Peak Torque × Angular Velocity,

$$= 51.5025 \times 41.67$$

Peak Power = 2146.109 Watt

Assuming rolling friction coefficient to be 0.01 at 45kmph,

Continuous Power,

Rolling Resistance =

Rolling Friction coefficient ×

weight of vehicle × Average Speed

$$= 0.01 \times 175 \times 9.812 \times 45 \times (5/18)$$

$$= 214.6375 \text{ Watt}$$

Continuous Speed = Average Speed × 60 / (2 × Pi × Radius of Wheel)

$$= 45 \times (5 / 18) \times 60 / (2 \times \pi \times 0.3)$$

$$= 397.88 \text{ RPM}$$

Continuous Torque =

$$\frac{\text{Rolling Resistance} \times 60}{2 \times \pi \times \text{continuous speed}}$$

$$= 214.6375 \times 60 / (2 \times \pi \times 397.88)$$

$$= 5.15 \text{ Nm}$$

Sr. No	Parameter	Value
1	Vehicle Weight	115 kg
2	Wheel radius	0.3 m
3	Friction coefficient of wheels (μr)	0.6-0.7
4	Maximum Speed	83kmph
5	Average Speed	45kmph

Based on the above estimations and imposed constraints in the rule book, we have chosen to opt for a 2.0 KW BLDC motor .

Following are the specifications of the motor:

Sr.no	Parameter	Value
1	Brand	Mechatronics Trading
2	Power Rating	2000 watts (Rated)
3	Voltage	48 V
4	Rated torque	7.6 N-m
5	Peak Power	3000 watts
6	Max Current	42 Amps
7	Rated Current	55 Amps
8	IP Rating	IP33
9	Max Efficiency	>87%

10	Net Weight	5.9 Kg
----	------------	--------

7.2 ENERGY STORAGE SYSTEM

Selected Battery: Lithium-ion battery (Li-ion) The Lithium ion (Li-ion) battery is a type of rechargeable battery which uses Li-ion as a cathode material, and a graphitic carbon electrode with a metallic current collector grid as the anode.

Reasons for selecting Li-ion Battery:

- Li-ion Batteries are selected for our vehicle due to the following advantages that they have over conventionally used Lead Acid Battery.
- **Weight:** Li-ion batteries are lighter than lead acid batteries usually weighing about 1/4 of them.
- **Efficiency:** Li-ion batteries are nearly 100% efficient in both charge and discharge, allowing for the same amp hours both in and out. Lead acid batteries' inefficiency leads to a loss of 15 amps while charging and rapid discharging drops voltage quickly and reduces the batteries' capacity.
- **Discharge:** Li-ion batteries are discharged 100% versus less than 80% for lead acid. Most lead acid batteries do not recommend more than 50% depth of discharge.
- **Cycle Life:** Rechargeable Li-ion batteries have a life span 10 times longer than that of traditional lead acid batteries. This dramatically changes the need for battery changes.
- **Voltage:** Li-ion batteries maintain their voltage throughout the entire discharge cycle. This allows for greater and longer-lasting efficiency of electrical components. Lead acid voltage drops consistently throughout the discharge cycle.
- **Cost:** Despite the higher upfront cost of Li-ion, the true cost of ownership is far less than lead acid when considering life span and performance.
- **Environmental Impact:** Li-ion batteries are a much cleaner technology. At the end of their useful life; batteries can be recycled and are safer for the environment.

On Basis of calculations and other constraints . we can conclude the required specification for Battery required for optimum performance of the vehicle.

To obtain required voltage, batteries should be connected in series,

No. of batteries in series

$$= \text{Required voltage/Nominal Voltage} = 48/3.7 = 12.97 = 13 \text{ nos.}$$

Thus, 13 Batteries are needed to be connected in series to obtain 48 Volts.

To obtain required battery capacity, batteries should be connected in parallel.

No. batteries in parallel

$$= \text{Required capacity/Nominal capacity} = 72/2.5$$

Sr. No	Parameter	Value
1	Voltage	48V
2	Battery capacity	72Ah
3	Maximum Discharge current	144A

$$= 29 \text{ nos.}$$

Thus, 29 series set Batteries are needed to be connected in parallel to obtain 72 Ah.

Total nos. of cells required =

$$\text{No. of batteries in series} * \text{No. of Batteries in Parallel} = 13 * 29 = 377$$

BODYWORKS

INTRODUCTION

A **motorcycle bodywork** is shell placed over the frame of a motorcycles especially sports and racing bikes, in order to reduce air drag and protect the rider from airborne hazards and also to protect the motorcycle components.

There are **three** types of motorcycle fairing:

1. **Side Fairing**
2. **Rear Fairing**
3. **Tank**

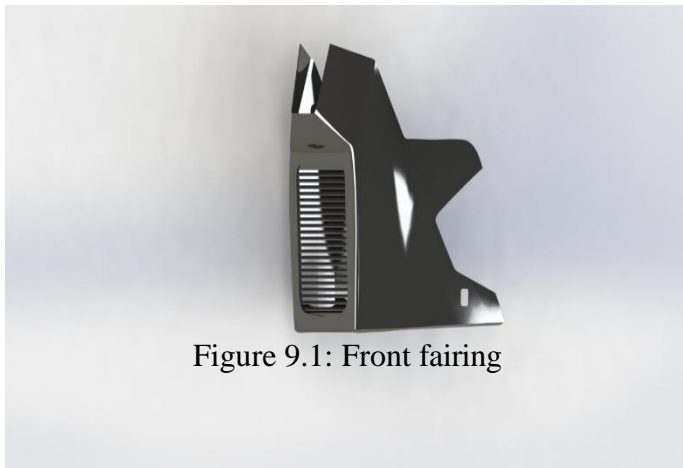

Figure 9.1: Front fairing

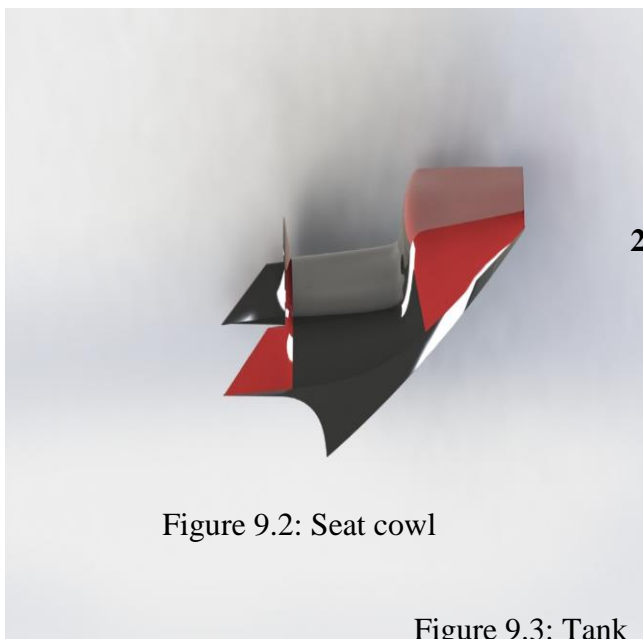

Figure 9.2: Seat cowl

Figure 9.3: Tank

The main motive of a fairing on a

motorcycle is reduction in aerodynamic drag, which allows for reduced battery consumption in an electric bike.

THEORY

Bodyworks are the external structure of a motor vehicle. There are five generally used fairing materials

1. ABS Plastic:

Acrylonitrile Butadiene Styrene (ABS) is a strong, cheap, easily accessible, durable but a heavy material. One of the advantages of ABS is that it can be given any shape by using moulding like injection or compression moulding. These moulding requires the manufacturing of dies which are quite expensive.

2. Sheet Metal (SM):

SM is the most economical option, since it provides good strength and can be given any curvature by hand. It is also easily available and be given variable thickness to ensure maximum strength required.

3. Polycarbonate Sheet (PC):

Polycarbonate sheet is the most economical option as it is easily available and less expensive compared to the other four materials mentioned above. It has relatively low density compared to other materials, also it can be easily bendable, thus giving a good curvature as required.

4. Carbon Fiber (CF):

CF is the best material not only for providing less weight but giving more strength, as CF has one of the highest strength to weight

Material	Resin
300g (1oz) CSM	650g Resin per sq mt
450g (1 ½ oz) CSM	1kg Resin per sq mt
600g (2oz) CSM	1.4kg Resin per sq mt
900g (1oz) CSM	2 kg Resin per sq mt
125g Plain weave Glass cloth	150g Resin per sq mt
200g Plain weave Glass cloth	250g Resin per sq mt
300g Woven Roving	300g Resin per sq mt
600g Woven Roving	600g Resin per sq mt

ratio. It is the most expensive of the four. It is very fragile and the repairing is almost non-existent.

5. Glass Fiber Reinforced Plastic (GFRP):

GFRP is comparatively lighter material, fragile. GFRP is not highly flexible but more flexible than carbon fiber and may get easily damaged but repairing the bodyworks of this material is also an easy task. Cloth of woven fiber and adding epoxy to the damaged area is one of the methods for repairing. Generally, this material is used in the bodyworks of a track

bikes. It is moderately expensive. It has a strength to weight ratio of approx. 1300.

Advantages are:

- Up to a 60% reduction in weight
- Improved surface quality and aerodynamics
- Reduction in components by combining parts and forms into simpler molded shapes.
- Pedals can be molded as single units combining both pedals and mechanical linkages simplifying the production and operation of the design.
- Fibers can be oriented to reinforce against specific stresses, increasing the durability and safety.

Generally speaking, the higher the resin content, the more corrosion resistant the laminate. Another very distinct advantage of GFRP is its low weight-to-strength ratio. As a rule of thumb, for the same strength, GFRP will weigh approximately one seventh as much as steel, and half as much as aluminum.

Hence considering all the factors and advantages, **GFRP is the chosen ideal material for manufacturing of bodywork components.**

CALCULATIONS:

Selection of type of GFRP and the amount of resin required is mentioned in the table below

(Highlighted values are used while manufacturing the bodyworks)

Percentage of Catalyst to Resin:

Material	Elastic Modulus (GPa)	Elongation Strength (GPa)
Carbon Fiber	253	4.5
Glass Fiber	86	4.5

Catalysts are added in order to improve the process of GFRP manufacturing, the amount of catalyst added in resins at various temperatures is given in the table below:

(Highlighted values are used while manufacturing the

Temp eratu r e	5 - 13°C	13 - 16°C	16 - 20°C	20 - 35°C
RESI N	%	%	%	%
500g	20ml	15ml	10ml	5ml
1kg	40ml	30ml	20ml	10ml
2kg	80ml	60ml	40ml	20ml
3kg	120ml	90ml	60ml	30ml
4kg	160ml	120ml	80ml	40ml
5kg	200ml	150ml	100ml	50ml

bodyworks)

EXAMPLE:

Resin is calculated between 2-2.5:1 Resin to Glass ratio.

So, you have 10.8 kg of fiber glass matting,
 $10.8 \times 2 = 21.6$ kg of Resin minimum, say 23kg of resin to be safe.

Analysis

Aerodynamics is the study of a body moving through air. Studying the motion of air around an object allows us to measure the forces of lift ,drag ,downforce and thrust which allows an bike to overcome drag, which is the resistance an bike “feels” as it moves through the air,

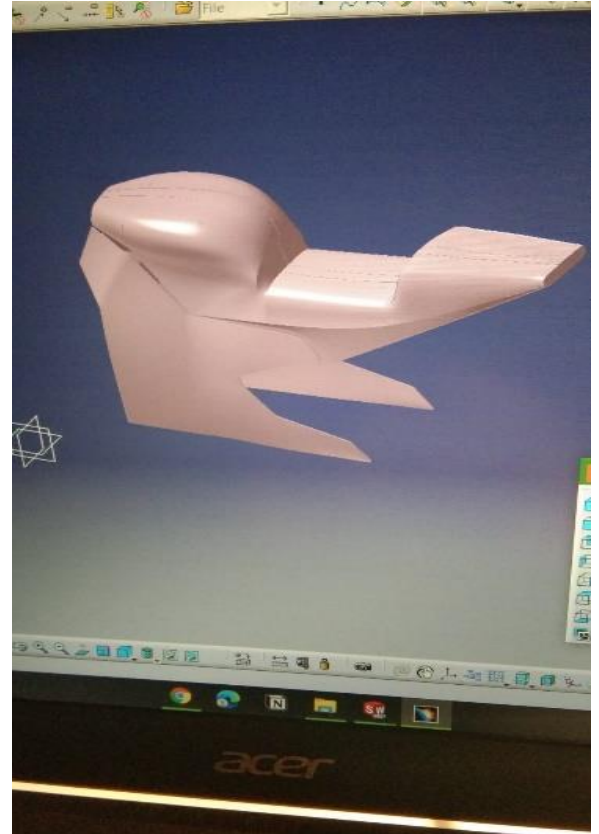

The aerodynamics of the vehicle changes with the structure of the vehicle which must be painstakingly considered while its design. In any case, the streamlined improvement experiences from the timeliest stages, in the design upgrade program, and remains up to full creation level, until the moment that the detail is progressed. The wind tunnel estimations keep on being the most well-known and broadly utilized methodology. The iterative simulation techniques through computational fluid dynamics (CFD) with high-end computers are used for aiding and reducing the trial tests. Proposed work is focusing on the investigative analysis of a motorbike for different models. Through the CFD analysis, various motorcycle models and radiator profiles are examined for the different flow conditions. The comparison of the aerodynamic drag acting on conventional motorcycle, radiator motorcycle, and superbike using computational fluid dynamics (CFD) estimated that the superbike model having lowest amount of drag coefficient of 12% by basic conventional model. Therefore, through this CFD analysis the airflow and advancements in the design of an efficient motorbike in terms of better riding ability, control, comfort, and low fuel consumption

are observed. The software used for the analysis of airflow is discovery live. Using this software we modified the bodyworks for optimum airflow around the bike hence reducing the drag and increasing speed.

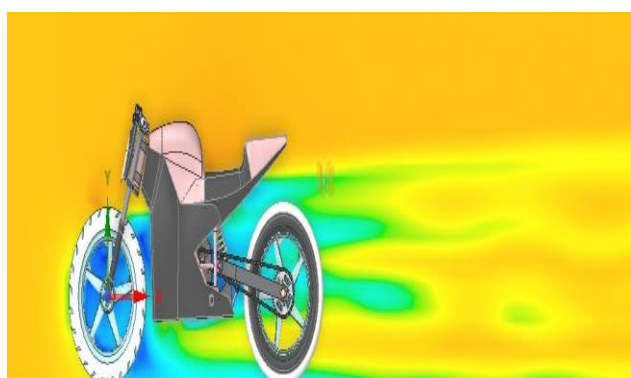
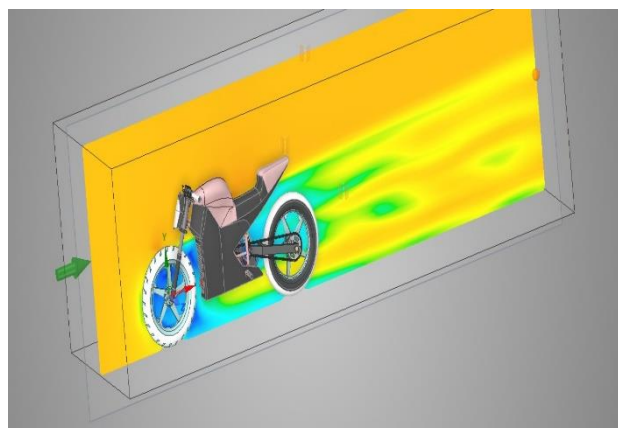

8. REFERENCES

1. Bhandari, V. B. (2016). Design of Machine Elements. India: McGraw-Hill Education (India).
2. Foale, T. (2006). Motorcycle Handling and Chassis Design: The Art and Science. Spain: Tony Foale.
3. Theede, P., Parks, L. (2010). Race Tech's Motorcycle Suspension Bible. United States: Motorbooks.
4. Sripathi, Aditya, "The Impact of Active Aerodynamics on Motorcycles Using Computational Fluid Dynamics Simulations" (2017). All Theses, Dissertations, and Other Capstone Projects. 721.
5. Sedlak, V. (2012). Motorcycle cornering improvement: An aerodynamical approach based on flow interference.
6. Cossalter, V. (2006). Motorcycle Dynamics. Italy: Vittorio Cossalter.
7. Walker, J. (2006). High-Performance Brake Systems. (n.p.): CarTech, Incorporated.

