

AI and Web-Based Interactive College Enquiry Chatbot

Akshada Phalle¹, Saniya Kadam¹, Sakshi Sonphule¹, Ila Savant²

¹Department of Computer Engineering, Marathwada Mitra Mandal's College of Engineering, Maharashtra, India

²Assistant Professor, Department of Computer Engineering, Marathwada Mitra Mandal's College of Engineering, Maharashtra, India

Abstract - Recently many business websites have started using chatbots as assistance let it be finance, health care, traveling domain. Chatbots are improving the way of communication in the virtual world. Chatbots are nothing but AI assistants. AI conversational assistant is a computer program that can be used for online interaction through text or voice messages. They can make human interaction contextual which leads to actual engaging interaction. Python's Rasa X is a framework that is a powerful tool in the creation of chatbots that can serve as a college enquiry system. Rasa X 's made up of Rasa NLU which can be considered as a human ear to listen to what has been said. Another important part of this framework is the Rasa core which is nothing but the brain that decides what to say. Rasa NLU focuses on user queries to identify the intent of the user's message and extract entities from the message to save them in the bot's memory. The core part takes custom actions that can include a call to the database or a request to an API call. This research study is focused on identifying the requirements for the development of a dynamic chatbot that supports text as well as voice-based interaction with the users.

Key Words: Artificial Intelligence, Rasa X, Machine learning, College enquiry chatbot, Human-computer interaction, Natural language processing, Speech-to-text.

1. INTRODUCTION

College students often need information regarding college such as timetable, upcoming events of college, about faculties, exam timetables, new assignments and projects with their deadline many more. The traditional way such as making phone calls, browsing the school website, or sending emails is inconvenient and time-consuming since you have to wait for a long time before you get an answer from the other side. If physical support is not available then calling doesn't help in some cases. Chatbots are changing the way of communication over the past few years it has been observed that most of the websites refer to chatbot interaction over actual physical calling support. So, a solution such as a Voice Chatbot is the easiest system to access for any user and is available 24 x 7. Anyone, Anywhere, Anytime without any problem can make use of internet connection and mobile device or other laptop devices to solve doubts. The objective of this research study is to identify the appropriate software components needed for developing a chatbot support system using Machine Learning and Natural Language Processing which can take input through voice as well as text and can easily extract intent and entity of user's message as it can be

easily integrated with college website to provide precise and accurate answers to college-related queries by students or parents. To minimize the load of offices of universities and increase interaction between student and college without actually involving any physical human entity that can promote student engaging system with great user interface and quick response.

2. LITERATURE SURVEY

Authors Siti Nazurah Mohd Sau Pi, Mazlina Abdul Majid [1] identified six components of the Smart Chatbot Academic Model through an extensive literature survey from the years 2017-2020. They compared existing chatbot applications for university websites and identified their purpose, type, character, and the programming languages behind them. However as this was a research work, they were unable to validate the identified components and hence could not proceed with the designing and development of the proposed product.

Authors Yurio Windiatmoo, Ridho Rahmadi, Ahmad Fathan Hidayatullah [2] implemented a chatbot based on deep learning which could be integrated with Facebook Messenger to answer university-related queries. The evaluation results of the model gave nearly perfect scores of precision, recall, and F1 with fast response time. However, the chatbot had not been used operationally on campus and thus its effectiveness and ease of use for users could not be measured yet.

Authors Olusegun Lala, Temilola Okedigba, Halleluyah Oluwatobi Aworinde [3] implemented an admission enquiry chatbot using IBM Watson for rapid response to admission related queries. When evaluated with Botium, the chatbot gave an accuracy of 95.9% with optimal and real-time feedback. While the model was successful in most aspects, it could only answer text-based queries with no support for voice input.

Authors S. Kumari, Z. Naikwadi, A. Akole, P. Darshankar [4] implemented a voice and text-based chatbot which could answer admission-related queries. In addition to the previously implemented works, this chatbot allowed the users to express their satisfaction with the provided answers by pressing the like or dislike buttons. This data was stored at the backend which served as a guideline for the Administrator to improve the answers framed. However, it could not understand the user's query if there were any glitches in input due to human spoken language, like a grammar error or a context error.

Authors Koundinya Hrushikesh, Ajay Krishna Palakurthi, Vaishnavi Putnala, Ashok Kumar [5] implemented an online chatbot system for visitors to the college website based on the AIML language which is a type of XML that enables the

user to get academic information. The chatbot utilized WordNet calculation and grammatical form labeling to distinguish the feeling of the words. The main limitation of WordNet is that it does not provide a clear distinction criterion between atomic and non-atomic lexical units due to which the chatbot is unable to recognize more words.

Authors Neelkumar P. Patel, Devangi R. Parikh, Darshan A. Patel, Ronak R. Patel [6] developed an interactive university chatbot with a GUI similar to a conventional messaging application that could answer text-based queries with minimal response time and very few database hits. On the downside the chatbot worked well only if the user framed the query using predefined keywords; it provided default answers when synonyms of keywords were used.

Authors Kulkarni, Pradnya, Ameya Mahabaleshwarkar, Mrunalini Kulkarni, Nachiket Sirsikar and Kunal Gadgil [7] threw light on the latest research in the field of Conversational AI along with the improvements achieved over the traditional counterparts. They explored the three main components of Conversational AI along with their accuracy, methodologies, and drawbacks.

Authors Ralston, Kennedy, Yuhao Chen, Haruna Isah and Farhana Zulkernine [8] developed a voice interactive and multilingual chatbot that could effectively respond to the users' mood, tone, and language using IBM Watson Assistant for responding to users' needs regarding exam stress. While it was a novel approach to the existing works, it could provide only about 76.5% accuracy.

Authors Xiong, Wayne, Lingfeng Wu, Fil Allewa, Jasha Droppo, Xuedong Huang, and Andreas Stolcke [9] enhanced their conversational speech recognition system based on Microsoft for Switchboard and CallHome domains by adding the CNN-BLSTM system. The resulting system had reduced error rates than its previous iterations.

The following table contains the comparison of various existing chatbot frameworks that were considered while designing the proposed chatbot.

A survey conducted by Braun, Daniel, Adrian Hernandez Mendez, Florian Matthes, and Manfred Langen [10] compares the NLU capabilities of the above frameworks. As chart-1 shows, Rasa ranks second overall and outperforms Watson and DialogFlow. This supported our decision to use Rasa as the framework behind our proposed chatbot.

Table -1: Comparison of Existing Chatbot Frameworks

Framework	Hosting Model	Pricing	Languages Supported
DialogFlow	Cloud	Free with optional enterprise plan	Vary by channel
Amazon Lex	Cloud	Pay per use	English
IBM Watson	Cloud	Varies. 10000 free transactions per month	English, Japanese
Microsoft LUIS	Cloud	Basic: Up to 1000 transactions per second; \$0.75 per 1000	Vary for prebuilt entities and prebuilt domains

		transactions	
Rasa	Local	Open Source	English, German

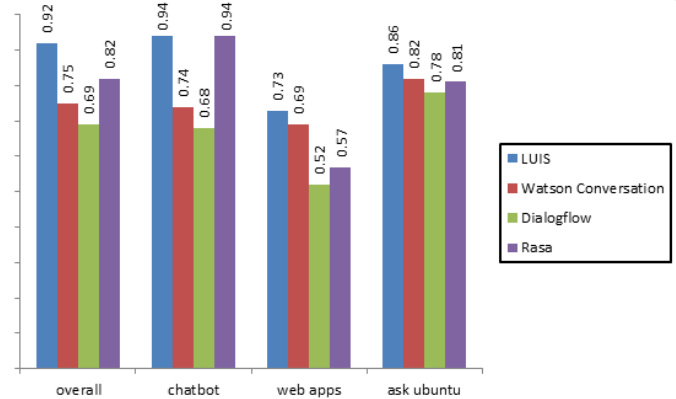

Chart -1: Performance Comparison of Chatbot Frameworks [10]

3. PROPOSED SYSTEM

3.1 Project Scope

The chatbot is an AI-based chatbot that receives questions from users in audio or textual format, converts the audio into text format, tries to understand the question by processing the text using NLP, and finds an appropriate answer to the question. In natural language processing, human language is divided into several pieces so that the grammatical structure of statements and the meaning of those pieces can be analyzed and understood in context to the whole conversation. This lets computers read and understand spoken or written text in the same way as humans. For example, when the chatbot receives the question "How many departments are there in the college?" it will answer "The college has 6 departments". The main objective is to reduce the burden on the college faculties by deferring the responsibility of answering the visitors' doubts regarding the college to the chatbot by creating a web-based chatbot that can be incorporated with the college website and can answer the users' text as well as audio-based queries. The goal is to provide visitors and faculty a quick and easy way to have their doubts answered as well as offer the developers the means to incorporate new information in the chatbot's information repository.

3.2 User Classes and Characteristics

The two classes of users for this application based on the mode in which they query the chatbot are as follows:

1. Text- These users provide input in textual format by typing in the text box.
2. Audio- These users provide input in audio format which will first be converted into a textual format or the chatbot server to process.

3.3 System Architecture

Rasa is an open-source machine learning framework to automate text-and voice-based conversations. It should provide us with all the functionality that we might need for implementing the project. Rasa helps us build contextual assistants capable of having layered conversations with lots of back-and-forths. Python's pyttsx3 library should be sufficient for converting audio into text.

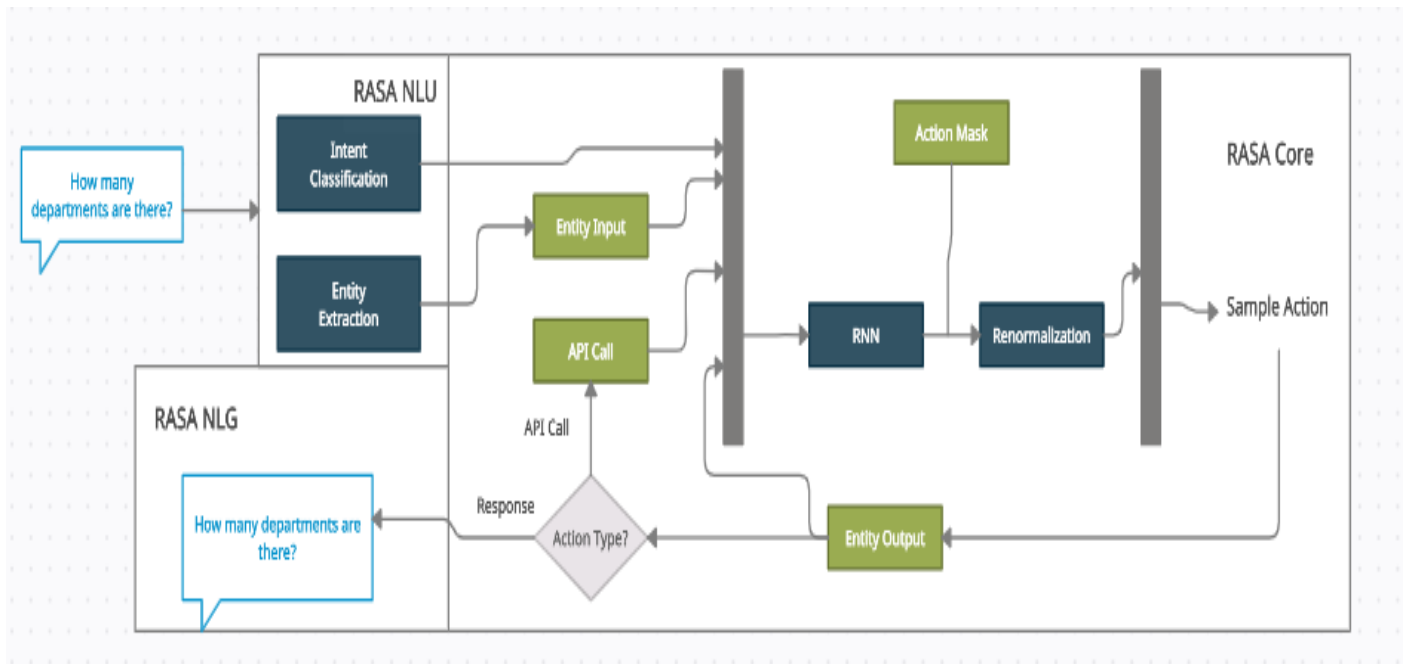

Fig -1: System Architecture

3.4 Functional Requirements

1. Users should be able to enter their query textually or in audio format.
2. The chatbot should be able to process that query.
3. It should fetch an appropriate response.
4. It should be able to relay that response to the user.
5. In case the query is out of scope, provide a default answer.

3.4 Database Requirements

1. NLU Dataset with more than 100 examples for intent.
2. NLU Dataset with more than 100 examples for the entity.
3. Stories dataset with starting stories.
4. One dataset specifying Rules for the chatbot.

3.5 Software Requirements (Platform Choice)

1. Operating System: Windows 10
2. Code Editor: Visual Studio Code
3. Programming Language: Python
4. Bot Framework: Rasa X
5. API: Google Speech Recognition API
6. Library: pyttsx3

4. LIMITATIONS

The proposed chatbot does not support regional languages. It would be able to process and answer questions in English only as it is the only language supported by Rasa NLU. spaCy is one of the default pipelines for processing user inputs in Rasa. While it works well when server capacity is low, demand for a higher configuration server to host the chatbot application might be a challenge.

5. CONCLUSION AND FUTURE WORKS

This research study proposes a college enquiry chatbot that can be integrated with a college website to interact with visitors and answer their questions about the college. The proposed chatbot will be able to accept both text-based as well as audio-based input from users. We have conducted a comprehensive literature survey to find the most appropriate chatbot framework and have referred to existing works that could provide an insight into the domains of NLP and Conversational AI.

This research study is focused on identifying the requirements for the development of a dynamic chatbot that supports text as well as voice-based interaction with the users. Thus the future work of this research study is to

implement said chatbot that could verify the hypotheses made.

REFERENCES

- [1] Pi, S.N.M.S. and Majid, M.A., 2020, December. "Components of Smart Chatbot Academic Model for a University Website". In 2020 Emerging Technology in Computing, Communication, and Electronics (ETCCE) (pp. 1-6). IEEE.
- [2] Windiatmoko, Y., Rahmadi, R. and Hidayatullah, A.F., 2021, February. "Developing Facebook Chatbot Based on Deep Learning Using RASA Framework for University Enquiries". In IOP Conference Series: Materials Science and Engineering (Vol. 1077, No. 1, p. 012060). IOP Publishing.
- [3] Gbenga, O., Okedigba, T. and Oluwatobi, H., 2020. "An Improved Rapid Response Model for University Admission Enquiry System Using Chatbot". *Int. J. Comput.*, 38(1), pp.123-131.
- [4] Kumari, S., Naikwadi, Z., Akole, A. and Darshankar, P., 2020, July. "Enhancing College Chat Bot Assistant with the Help of Richer Human-Computer Interaction and Speech Recognition". In 2020 International Conference on Electronics and Sustainable Communication Systems (ICESC) (pp. 427-433). IEEE.
- [5] Koundinya, H., Palakurthi, A.K., Putnala, V. and Kumar, A., 2020, July. "Smart College Chatbot using ML and Python". In 2020 International Conference on System, Computation, Automation, and Networking (ICSCAN) (pp. 1-5). IEEE.
- [6] Patel, N.P., Parikh, D.R., Patel, D.A. and Patel, R.R., 2019, June. "AI and web-based human-like interactive university chatbot (UNIBOT)". In 2019 3rd International Conference on Electronics, Communication and Aerospace Technology (ICECA) (pp. 148-150). IEEE.
- [7] Kulkarni, P., Mahabaleshwarkar, A., Kulkarni, M., Sirsakar, N. and Gadgil, K., 2019, September. "Conversational AI: An Overview of Methodologies, Applications & Future Scope". In 2019 5th International Conference On Computing, Communication, Control And Automation (ICCUBEA) (pp. 1-7). IEEE.
- [8] Ralston, K., Chen, Y., Isah, H. and Zulkernine, F., 2019, December. "A voice interactive multilingual student support system using IBM Watson". In 2019 18th IEEE International Conference On Machine Learning And Applications (ICMLA) (pp. 1924-1929). IEEE.
- [9] Xiong, W., Wu, L., Allewa, F., Droppo, J., Huang, X. and Stolcke, A., 2018, April. "The Microsoft 2017 conversational speech recognition system". In 2018 IEEE international conference on acoustics, speech and signal processing (ICASSP) (pp. 5934-5938). IEEE.
- [10] Braun, D., Mendez, A.H., Matthes, F. and Langen, M., 2017, August. "Evaluating natural language understanding services for conversational question answering systems". In Proceedings of the 18th Annual SIGdial Meeting on Discourse and Dialogue (pp. 174-185).