

# Elevated Water Tank Design and Seismic Study in Various Zones

Mr. Diwakar Yadav<sup>1</sup>, Mr. Vinayak Mishra<sup>2</sup>

<sup>1</sup>M.Tech, Structural Engineering

<sup>2</sup>Assistant Professor, Department of Civil Engineering, Institute of Engineering and Technology, Lucknow, Uttar Pradesh, India

\*\*\*

**Abstract:** *The need for water varies throughout the day. It changes from hour to hour. We need to store water in order to deliver a consistent volume of water. As a result, water tanks must be built to accommodate the public's need for water. They play a critical role in municipal water supply, firefighting systems, and a variety of other applications. In India, the Intze style of overhead water tank is widely used. The purpose of this research is to understand the behaviour of an overhead water tank responds to various loading situations during earthquakes. The Intze tank was designed using the IS:3370 part I (General Requirement) and Part II (Reinforced Concrete Structure) code of practice for concrete structures for liquid storage. In this research study the capacity of 250 m<sup>3</sup> intze tank has been constructed and studied using the response spectrum approach and SAP2000 is used to do the analysis. Seismic response parameters such as base shear, base moment, and tank displacement under empty and full conditions in seismic zones II, III, IV, and V were computed and the results were compared.*

**Keywords** - water tank, SAP2000, seismic analysis Response spectrum

## 1. INTRODUCTION

An elevated water tank is a big water storage container designed to store water supply at a certain elevation in order to pressurise the water distribution system. For the storage of water and other liquid fluids in various forms and styles, many new concepts and innovations have been developed. Liquid storage can be done in a variety of methods, including subterranean, ground-supported, raised, and so on. Municipalities and industry utilise liquid storage tanks widely to store water, flammable liquids, and other chemicals. Thus Water tanks are critical for both public utility and industrial structures. Water tanks are critical components of the lifeline system. Every conception begins with water. One cannot survive without water in everyday life. The most effective storing competency employed for residential or even industrial purpose is the overhead liquid storing tank. Water tanks can be classified as above, on the ground, or subterranean, depending on their placement. Tanks may be built in a variety of forms, including rectangular, round, and Intze.

Elevated water tanks are generally lower in capacity and are designed for direct gravity distribution of water.

Elevated water tanks are clearly displayed in public spaces, visible from both close and far distances. In India, the Intze style of overhead water tank is widely utilised. A significant number of overhead water tanks are now employed to supply water for public consumption. They are frequently used as markers in the landscape. As a result, the container's shape and form, as well as the supporting structure, must be given careful consideration from an aesthetic standpoint.

Water storage tanks should stay operational in the post-earthquake period to guarantee that earthquake-affected areas have access to drinkable water and to meet fire-fighting demands. Industrial liquid storage tanks may contain highly hazardous and combustible substances, and the contents of these tanks should not be lost in the event of an earthquake. Several big high water tanks were badly damaged during the earthquakes, but others were unharmed.

The motion of the water relative to the tank, as well as the motion of the tank relative to the ground, must be considered while analysing the dynamic behaviour of such tanks. Because it is intended for wind and seismic pressures, the existing design of supporting structures for elevated water tanks is particularly sensitive to lateral forces caused by an earthquake. Water tanks can be damaged in many components for a variety of causes, including incorrect structural configuration design, inferior materials and workmanship, reinforcement corrosion, wind forces, earthquake forces, and so on. The lateral force design parameters in the zone of strong seismic activity are more or less governed by earthquake forces because of the enormous mass, especially when the tank is full. Total tank collapse must be prevented in the worst-case scenario. Some damage (repairable) may, nevertheless, be acceptable.

Liquid storage facility is commonly referred to as "Water Tank." A water tank is a container that may be used to store water for a variety of purposes. Storage reservoirs

are large water tanks that are also known as storage tanks. Ground storage is made of-

1. Underground storage reservoir (USR)
2. Ground storage reservoir (GSR)
3. High ground level storage reservoir (HGLR).

Elevated tanks can also be referred to as elevated storage reservoirs (ESR). The following items are needed to construct a water tank.

1. Plastics
2. Fiberglass
3. Concrete
4. Stone
5. Steel

The size, cost, shape, and materials used to construct water tanks varies in proportion to the capacity of the water tank. Water tanks' principal purpose is to maintain a

## 2. COMPONENTS OF INTZE TANK

The following are the various components of an Intze type tank.

**A. Top Spherical Dome (cover roof)-** Steel is provided throughout the meridians and latitudes by the upper dome, which is typically 100 mm to 150 mm thick. The increase is usually around one-fifth of the span. If not stated, the top dome must be built for a live load of 1.5kN/m<sup>2</sup>.

**B. Top Ring Beam B<sub>1</sub>-** The ring beam resists the horizontal component of the dome's force. The controlling factor for ring beam design is hoop tension. The meridional thrust of the top dome comprises two elements at the level of the top ring beam: a vertical component and a horizontal component. As a result, the vertical component of the dome's downward load (DL+LL) is transferred via the side circular wall. The horizontal portion creates hoop stress on the beam that is being constructed.

**C. Vertical Side Walls-** The cylindrical side of the hoop should be constructed to accommodate hoop tension generated by horizontal water pressure. Due to the water load, the circular wall on the side that is deemed free to move at the top and bottom is exposed to hoop stress. With the depth of the wall, the hoop tension increases.

suitable static head in a continual water supply from a distance to the target place under gravity.

Tanks that are elevated offer several advantages. Pumps do not need to be running continuously in high tanks. Pumps that are turned off for a short period of time have no effect on the water pressure in the distribution system since pressure is maintained by gravity. This explains why the raised tanks are so tall. The water pressure that comes out of an elevated tank is determined by the depth of the water in the tank. A almost empty tank cannot produce enough water pressure, but a completely filled tank can. At only one depth, the maximum pressure is attained. The most basic form of raised tank is a square or rectangular tank supported by four columns and flanged beams. A broad range of raised water tanks are utilised for both economic and aesthetic reasons. The raised tank's design includes:

1. Tank(container) Design
2. Staging Design
3. Foundation Design

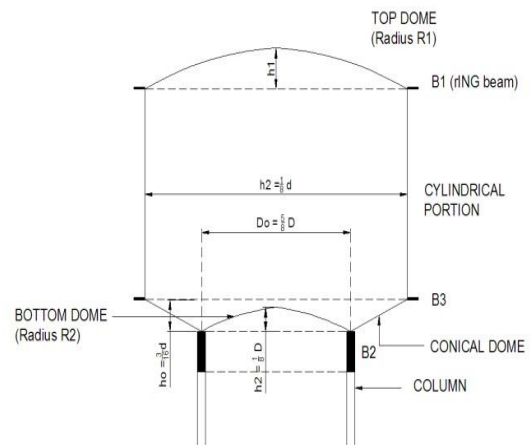

Fig -1: Component of Intze Tank

**D. Bottom Ring Beam B<sub>2</sub> -** This ring beam is designed to withstand the conical wall's horizontal response in the cylindrical wall. The controlling factor for ring beam design is hoop tension. The beam's diameter is generally kept as wide as possible so that it may be used as a walkway around the tank.

**E. Conical Dome -** The conical dome was created to accommodate hoop tension generated by water pressure. The slab will also be built as a spanning slab between the top and bottom ring beams and ring girders. The hoop

tension may be adjusted. The dome's dead weight is applied vertically downward, while the water pressure is applied perpendicular to the inclined surface.

**F. Bottom Spherical Dome-** The floor might be domed or round. A ring girder is used to support this slab. The bottom spherical dome is designed to support water loads in excess of its own weight. A lower circular beam also supports the dome. The circular beam receives meridional force.

**G. Bottom Circular Girder -** This is construct to support the tank and its contents. The girder can be supported by columns. This should be construct for resulting bending moment and Torsion.

### 3. DESIGN OF INTZE TANK AS PER IS:3370

#### 3.1. General

In this portion design of different components of an intze tank having capacity 250kL are discribed. Modeling of tanks with different types of bracing patterns are done using SAP2000v21 in this chapter.

#### 3.2. Design data

Concrete grade -M30 grade for container,

Reinforcement -HYSD(Fe415)

Capacity of tank(V)=

$$\left[\frac{\pi}{4}d^2h + \frac{\pi h_0}{12}(D^2 + D_0^2 + DD_0) - \frac{\pi h_2^2}{3}(3R_2 - h_2)\right]$$

Diameter of lower ring beam(B<sub>3</sub>) D<sub>0</sub>= $\frac{5}{8}D$

Height of conical dome h<sub>0</sub>= $\frac{3}{16}D$

Rise of bottom dome h<sub>2</sub>= $\frac{1}{8}D$

$\frac{h}{D}$ =0.5 where h=Height of circular wall

$$V=0.47D^3$$

Capacity of tank (V)=250kl

D=8.10m, h=4.05m, h<sub>1</sub>=1.2m, D<sub>0</sub>=5.06m, h<sub>0</sub>=1.52m, h<sub>2</sub>=1.01m

#### 1) Top Dome

$$h_1(2R_1 - h_1) = \left(\frac{D}{2}\right)^2$$

$$1.2(2R_1 - 1.2) = (8.10/2)^2$$

$$R_1 = 7.43 \text{ m}$$

$$\sin \phi_1 = \frac{8.10}{2 \times 7.43} = 0.545$$

$$\cos \phi_1 = 0.838$$

Assume thickness of slab=100mm

$$\text{Self weight} = 0.1 \times 25 = 2.5 \text{ kN/m}^2$$

$$\text{Live load} = 1.5 \text{ kN/m}^2$$

$$\text{Total Load} = 4.0 \text{ kN/m}^2$$

$$\begin{aligned} \text{Meridional force} &= \frac{wr(1 - \cos \theta)}{\sin^2 \theta} \\ &= 16.20 \text{ kN} \end{aligned}$$

$$\begin{aligned} \text{Meridional stress} &= \frac{16.20 \times 10^3}{10^3 \times 100} \\ &= 0.162 < 8 \text{ N/mm}^2 \text{ (safe)} \end{aligned}$$

$$\begin{aligned} \text{Hoop force} &= \frac{wr(1 - \cos \theta - \cos^2 \theta)}{(1 + \cos \theta)} \\ &= 8.75 \text{ KN tensile} \end{aligned}$$

$$\begin{aligned} \text{Hoop stress} &= \frac{8.73 \times 10^3}{10^3 \times 100} \\ &= 8.735 \text{ kN tensile} \\ &= 0.087 < 1.5 \text{ N/mm}^2 \text{ (safe)} \end{aligned}$$

#### 2) Top Ring Beam(B<sub>1</sub>)

$$\text{Ring Beam Width} = \left(\frac{1}{30} - \frac{1}{24}\right) \text{ of } D$$

$$= 0.27 \text{ m} - 0.33 \text{ m}$$

$$= 300 \text{ mm (taken)}$$

Ring Beam Depth=0.4 to 0.6 of width

$$= 0.12 \text{ m} - 0.18 \text{ m}$$

$$= 150 \text{ mm}$$

Assume size of beam 300mm×150mm

#### 3) Cylindrical Wall

$$\text{Hoop Tension} = \frac{\gamma_w h D}{2}$$

$$\begin{aligned} &= \frac{10 \times h \times 8.10}{2} &= 10 \times 4.0 \times 0.6 \\ &= 40.5h &= 24.3 \text{ kN/m} \\ &= 40.5 \times 4.05 = 164 \text{ kN (maximum)} \end{aligned}$$

$$\begin{aligned} H &= H_1 + H_2 \\ &= 89.53 \text{ kN/m} \\ \text{Hoop tension} &= \frac{HD}{2} \\ &= 362.59 \text{ kN/m} \end{aligned}$$

$$\begin{aligned} A_{st} &= \frac{T}{130} \\ &= \frac{164 \times 10^3}{130} \\ &= 1261.5 \text{ mm}^2 \end{aligned}$$

$$\begin{aligned} A_{st} &= \frac{362.59 \times 10^3}{130} \\ &= 2789.20 \text{ mm}^2 \end{aligned}$$

$$\begin{aligned} f_{ct} &< 1.5 \text{ N/mm}^2 \\ A_T &= 1000t + (9.33 - 1) \times 1261.5 \end{aligned}$$

$$\begin{aligned} A_T &= 1000 \times 600 + (9.33 - 1) \times 2789.2 \\ &= 623234.0 \text{ mm}^2 \end{aligned}$$

$$\begin{aligned} f_{ct} &= \frac{164 \times 10^3}{1000t + 10508.2} < 1.5 \\ 98.8 &< t \end{aligned}$$

$$f_{ct} = \frac{362.59 \times 10^3}{623234} = 0.58 < 1.5 \text{ N/mm}^2 \text{ (OK)}$$

Provide 450mm at base and linearly varying to 200mm at top.

### 5) Conical Dome

#### 4) Ring Beam (B<sub>2</sub>)

$$\text{average diameter} = \frac{(D + D_o)}{2} = 6.58 \text{ m}$$

$$\begin{aligned} \text{Top Dome load} &= 2\pi R_1 h_1 w \\ &= 224 \text{ kN} \end{aligned}$$

$$\text{average water depth} = 2.78 \text{ m}$$

$$\begin{aligned} \text{Load/m} &= \frac{224}{\pi \times D} \\ &= 8.8 \text{ kN/m} \end{aligned}$$

$$\begin{aligned} \text{water weight above conical dome} &= \pi \times 6.58 \times 2.78 \times 1.52 \times 10 \\ &= 873.50 \text{ kN} \end{aligned}$$

$$\begin{aligned} \text{Cylindrical wall load} &= 0.45 \times 4.05 \times 25 \\ &= 45.56 \text{ kN/m} \end{aligned}$$

Assume 500mm thick slab

$$\begin{aligned} \text{Width of slab} &= \sqrt{1.52^2 + 1.52^2} \\ &= 2.15 \text{ m} \end{aligned}$$

$$\begin{aligned} \text{Self-weight of } B_1 &= (0.3 - 0.2) \times 0.15 \times 25 \\ &= 0.375 \text{ kN/m} \end{aligned}$$

$$\begin{aligned} 2.15 \times 6.58 \times \pi \times 0.5 \times 25 \\ &= 555.55 \text{ kN} \end{aligned}$$

$$\begin{aligned} \text{Self-weight of } B_2 &= (1 - 0.3) \times 0.6 \times 25 \\ &= 10.5 \text{ kN/m} \end{aligned}$$

$$\text{Total Load} = 3089.0 \text{ kN}$$

$$\text{Total load} = 65.23 \text{ kN/m}$$

$$\text{Load/m (w}_2) = \frac{3089}{\pi \times 5.06} = 194.32 \text{ kN/m}$$

Adopted size of Beam 1000mm × 600mm

$$\begin{aligned} \text{Meridional thrust } T_3 &= \frac{194.32}{\cos \beta} \\ &= 274.80 \text{ kN/m} \end{aligned}$$

$$\begin{aligned} H_1 &= w_1 \tan \beta \quad \tan \beta = \frac{(D - D_o)}{2 \times h_o} = 1 \\ &= 65.23 \text{ kN/m} \end{aligned}$$

$$\begin{aligned} \text{Meridional stress} &= \frac{274.80 \times 10^3}{10^3 \times 500} \\ &= 0.549 < 1.5 \text{ N/mm}^2 \text{ (safe)} \end{aligned}$$

$$\text{Horizontal water force } H_2 = \gamma_w h d$$

### 6) Bottom Dome

$$h_2(2R_2-h_2) = (D_o/2)^2$$

$$1.01(2R_2-1.01) = (5.06/2)^2$$

$$R_2 = 3.67\text{m}$$

$$\sin \phi_2 = \frac{5.06}{2 \times 3.67} = 0.689$$

$$\cos \phi_2 = 0.724$$

Assume 250mm thick slab

$$\text{Self-sweight} = 2\pi R h t \times 25$$

$$= 2\pi \times 3.67 \times 1.01 \times 0.25 \times 25$$

$$= 145.56\text{kN}$$

Volume of water above dome =

$$\frac{\pi}{4} \times 5.06^2 \times 5.57 - \left[ \frac{2\pi \times 3.67^2 \times 1.01}{3} - \frac{\pi \times (3.67 - 1) \times 5.06^2}{12} \right]$$

$$= 101.33\text{m}^3$$

Weight of water above dome =  $101.33 \times 10$

$$= 1013.4\text{kN}$$

Total load = 1159kN

$$\text{Meridional thrust } T_4 = \frac{w}{\pi D \sin \theta}$$

$$= 105.82\text{kNm}$$

Meridional stress =  $0.42 < 8\text{N/mm}^2$  (safe)

$$\text{Hoop force} = \frac{WR}{2} \text{ tension}$$

### 4. ANALYSIS AND COMPARISON OF RESULTS

Capacity of 250m<sup>3</sup> water tank has been prepared and Analyzed in SAP2000 v21 software by response spectrum method to get following results with tank empty and full condition in different earthquake zones are given in table form and in earthquake analysis parameters comparison are shown in graph given below.

$$W = \frac{1159}{2\pi \times 3.67 \times 1.01} = 49.76\text{kN/m}^2$$

$$\text{Hoop tension} = \frac{49.76 \times 3.67}{2}$$

$$= 91.31\text{kN}$$

Hoop stress =  $0.36\text{N/mm}^2 < 1.5\text{N/mm}^2$  (safe)

### 7) Bottom Circular Beam(B<sub>3</sub>)

Inward thrust from conical dome =  $T_3 \cos \alpha$   
 $\cos \alpha = 0.70$

$$= 274.80 \times 0.70 = 192.36\text{kN/m}$$

Outward thrust from bottom dome =  $T_4 \cos \phi_2$

$$= 105.82 \times 0.724$$

$$= 76.61\text{kN/m}$$

Net inward thrust = 115.74kN/m

$$\text{Hoop compression in beam} = \frac{115.74 \times 5.06}{2}$$

$$= 292.8\text{kN}$$

Assume beam size 750mm × 1200mm

$$\text{Hoop stress} = \frac{292.8 \times 10^3}{750 \times 1200}$$

$$= 0.32 < 8\text{N/mm}^2 \text{ (OK)}$$

Provide nominal reinforcement 2800mm<sup>2</sup>

Further columns and braces for staging are designed using SAP 2000v21 software for different seismic zones by response spectrum method as per IS:1893 2016 part (2)

### 4.1 Time period

Time period is same for all seismic zones, only singly curve represents time period in all zones below.

Table 1. Time Period(sec) at empty condition and fill condition

Mode Number	Empty condition	Full condition
Mode 1	0.650477	1.074598
Mode 2	0.650477	1.074598
Mode 3	0.55418	0.877796

Mode 4	0.119604	0.171849
Mode 5	0.119604	0.171849
Mode 6	0.082736	0.117603
Mode 7	0.074034	0.114544
Mode 8	0.074034	0.114544
Mode 9	0.052082	0.085593
Mode 10	0.050027	0.07075
Mode 11	0.050027	0.07075
Mode 12	0.047895	0.068895

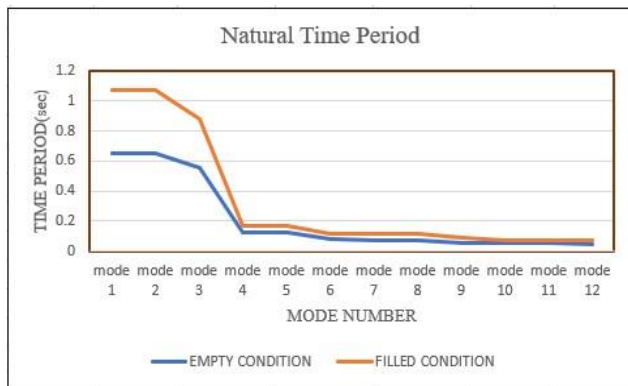

Graph1. fundamental natural time period

#### 4.2 Base shear

Base shear values in case of filled condition is more than empty condition because of weight of water in filled condition also included in base shear calculations.

Table 2: Base Shear(KN) for all seismic zones

Zone	Empty condition	Full condition
II	188.763	304.14
III	302.021	486.624
IV	453.032	729.935
V	679.548	1094.903

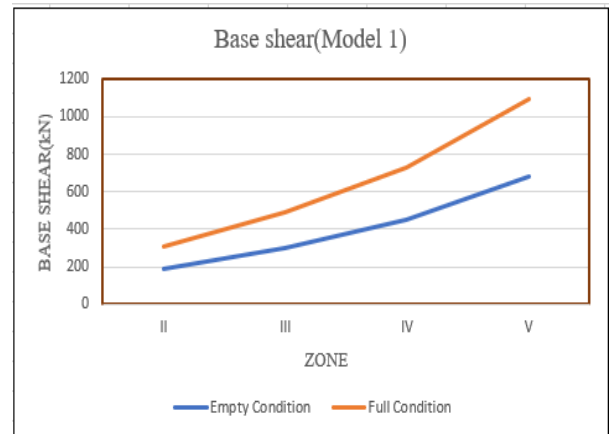

Graph2. Base shear for different seismic zone

#### 4.3 Base moment

Overturning moment values in case of filled condition is more than empty condition because of weight of water in filled condition also included in base moment calculations.

Table3. Base moment (KN-m) for all seismic zone

Zone	Empty condition	Full condition
II	3182.4385	5091.7627
III	5091.9016	8146.8204
IV	7637.852	12220.23
V	11456.778	18330.345

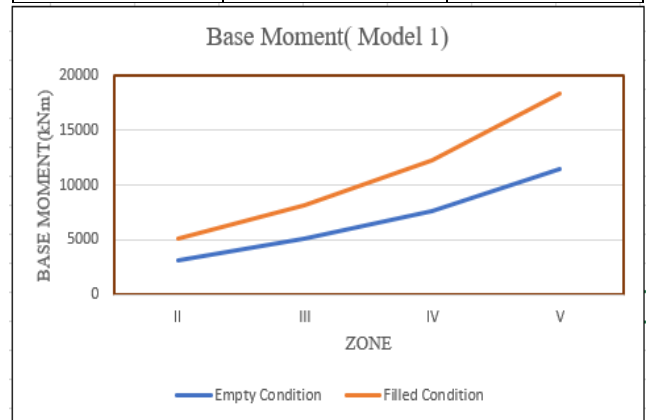

Graph3. Base moment for all seismic zone

#### 4.4 Story displacement

Story displacement values for filled condition are more than empty condition. Story Displacement values increases with increases in seismic intensity (zone II to Zone V)



Table4. Story displacement(mm) for all seismic zones

Story height from base (H)	zone	Empty condition	Full condition	Permissible limit (H/500)
16m	II	5.489	8.917	32
	III	8.783	14.268	32
	IV	13.175	21.402	32
	V	19.762	32.103	32
12m	II	4.28	6.933	24
	III	6.848	11.094	24
	IV	6.265	10.112	24
	V	9.398	15.168	24
8m	II	2.61	4.213	16
	III	4.177	6.741	16
	IV	6.265	10.112	16
	V	9.398	15.168	16
4m	II	0.975	1.571	8
	III	1.56	2.514	8
	IV	2.34	3.771	8
	V	3.511	5.657	8

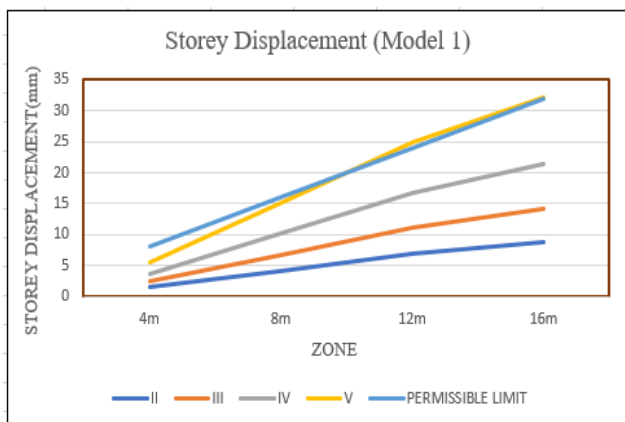

Graph4. Displacement for all seismic zones

## 5. CONCLUSIONS

The following are the key findings of this research.

1. In the Intze tank, a conical bottom and another spherical bottom are provided, which minimises the tensions in the ring beams.

2. While comparing the empty and full conditions, it can be seen that the full condition's base shear, base moment, and displacement are greater than the empty condition's. Since lateral force is greater in a full tank than in an empty tank, so that the full tanks example is used for seismic analysis.

3. Base shear and base moment are increasing as the seismic zone increases because base shear directly depends on zone factor

4. As seismic intensity increase, base shear values increase from zone II to V for empty and full conditions because base shear directly depend upon zone factor(Z). Zone factor value for seismic zone V (0.36) is maximum.

5. All seismic zones have the same time period. Base moment values rise from zone II to V for both circumstances as seismic intensity zones increase.

6. Story displacement values for filled condition are more than empty condition. Simple bracing fails in seismic zone V because story displacement values exceed allowed limit values; however, simple bracing is safe in seismic zones II, III, and IV because story displacement values are within permitted limit values (H/500).

## REFERENCES

- [1] A. H. Shrigondekar, G. D. Parulekar, and V. R. Kasar, "Behaviour of RC Overhead Water Tank Under Different Staging Patterns," *Int. J. Eng. Res.*, vol. V6, no. 04, pp. 538-541, 2017, doi: 10.17577/ijertv6is040442.
- [2] K. Harsha, "Seismic Analysis and Design of INTZE Type Water Tank," vol. 2, no. 03, pp. 11-24, 2015.
- [3] IS 3370:2009 (Part-2), "Code of Practice Concrete structures for the storage of liquids - Part 2: Reinforced concrete structures," Bur. Indian Stand. Delhi, 2009.
- [4] . G. P. D., "Analysis of Elevated Water Storage Structure Using Different Staging System," *Int. J. Res. Eng. Technol.*, vol. 04, no. 04, pp. 283-287, 2015, doi: 10.15623/ijret.2015.0404048.
- [5] C. Agari, V. K. Verma, and A. Gupta, "Seismic Analysis of Intze Water Tank with Different Bracing Configurations," no. 8, 2019.

- [6] P. D. Kumar, A. Aishwarya, and P. R. Maiti, "Comparative Study of Dynamic Analysis of Rectangular Liquid Filled Containers Using Codal Provisions," *Procedia Eng.*, vol. 144, pp. 1180–1186, 2016, doi: 10.1016/j.proeng.2016.05.096.
- [7] S. E. Ninan, "Seismic Analysis of Rectangular and Circular RC Elevated Water Tank," vol. 6, no. 06, pp. 5–8, 2018.
- [8] S. Nagorao Bengal and S. A. Tupat, "Seismic Analysis of Elevated Water Tank with Variations of H / D Ratio and Container Shape," *Int. J. Comput. Sci. Mob. Comput.*, vol. 6, no. 5, pp. 209–217, 2017.
- [9] M. N. Gandhi and A. Rajan, "Earthquake Resistant Analysis of Circular Elevated Water Tank with Different Bracings in Staging," vol. 3, no. 11, pp. 255–259, 2016.
- [10] S. S. Shinge, *IITK-GSDMA Guidelines for seismic design of liquid storage tanks*, no. January. 2007.
- [11] M. Sai Ramya and J. Sandhya Rani, "Seismic Analysis of RC Elevated Rectangular Water Tank using Various Staging Patterns," *CVR J. Sci. Technol.*, vol. 17, no. 1, pp. 25–29, 2019, doi: 10.32377/cvrjst1705.
- [12] S. C. Naik and M. S. Bhandiwad, "Seismic Analysis and Optimization of a Rectangular Elevated Water Tank," *Bonfring Int. J. Man Mach. Interface*, vol. 4, no. Special Issue, pp. 83–89, 2016, doi: 10.9756/bijmmi.8161.
- [13] S. Rathod and M. B. Ishwaragol, "Analysis of Overhead Water Tank With Different Staging Height and Base Width," *Int. Res. J. Eng. Technol.*, no. December, pp. 0–4, 2018, [Online]. Available: [www.irjet.net](http://www.irjet.net).
- [14] S. Mhamunkar, M. Satkar, D. Pulaskar, N. Khairnar, R. Sharan, and R. Shaikh, "Design and Analysis of Overhead Water Tank at Phule Nagar, Ambernath," *Int. Res. J. Eng. Technol.*, pp. 3851–3870, 2019, [Online]. Available: [www.irjet.net](http://www.irjet.net).