

# Comparative Study on IoT Enabled Smart Solutions to Avoid Human Elephant Conflicts

N Rajeswari<sup>1</sup>, A S Aarthi Mai<sup>2</sup>

<sup>1</sup> Assistant Professor, Department of Computer Applications, PSG College of Technology, Coimbatore, Tamilnadu, India

<sup>2</sup> Assistant Professor, Department of Computer Applications, PSG College of Technology, Coimbatore, Tamilnadu, India

\*\*\*

**Abstract** – Human Elephant conflict was foremost problem in India. Conflicts results in death of both humans as well as elephants. Humans had invaded into habitat of elephants for farming and living. Electrical fences are a traditional method to deter elephants entering into fields. Now a day's elephants turned smarter to enter the fields without breaking the fences. In this paper we review the IoT smart solutions to avoid human elephant conflicts experimented by different authors in various papers.

**Key Words:** Human Elephant Conflict, Internet of Things, Electrical Fence, Seismic Sensor, Piezoelectric Sensor

## 1. INTRODUCTION

Human animal conflict refers to interaction between man and animals in the negative side causes harm to both animals and humans. With the increase in human population, man has invaded into animal habitats for farmland expansion and living space [10]-[12],[17]. A common approach followed worldwide is usage of electrical fences to frighten animals from entering human livelihood. Trenches, bursting crackers, beating drums and flashing lights are few other methods followed to deter elephants and keeps them away from humans.

## 2. LITERATURE STUDY

Traditional methods to avoid animal intrusion are usage of electrical fences [4] and Chilli fences. [8]Chilli fences constructed using chilli, grease and bamboo poles with a little quantity of diesel. Chili fences are created by applying chili grease on rope fences erected around crop fields. Loud noises produced by beating drums, bursting crackers and flashing of lights. Creating smoke and fire and honey bees sound [16] also used to scare elephants. [14]Community Crop Guarding [18] helps the farmers to protect their crops from wild beasts. Creating physical barriers like elephant proof trenches [19] will prevent elephants from entering the fields. Formation of rapid response team to tackle emergency situations aids to avoid elephant entering fields.

This paper is organised with the following sections. In Section 3 discusses the IoT architecture for elephant detection system, its working setup, experimental results. In Section 4 discusses IoT enabled three Layer Piezoelectric

vibrating Sensor Detection System which prevents animal intrusion in better way along with sensor deployment and experimental results was presented. In Section 5 presents animal Intrusion and Detection system using IR sensor and results was discussed. In Section 6 depicts the layout of IoT enabled smart electric fences. At last the comparison of the above approaches was discussed.

## 3. IoT ARCHITECTURE FOR ELEPHANT DETECTION SYSTEM

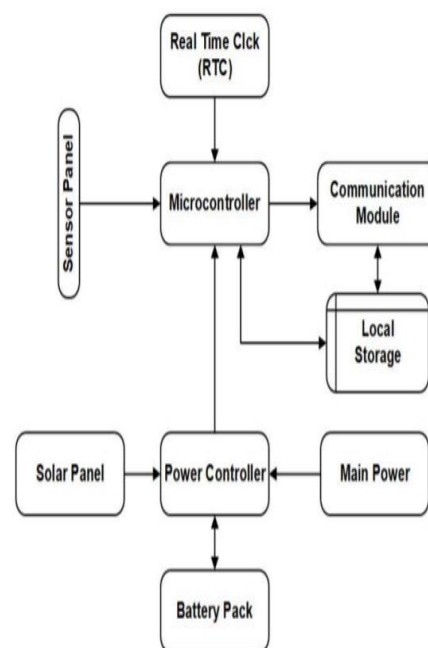

Fig 1 Architecture of IoT Enabled Smart Elephant Detection System

Mohammed et al[1] in their paper had designed an architecture of the IoT-enabled smart elephant detection system as shown in fig 1. This design comprises of sensor panels, communication module, battery backup, solar panel, micro controller, communication module and storage. The sensor panel is a flexible enough to accommodate any type of sensor irrespective of its method. A geophone is used as the low frequency underground (Seismic) sensor for detecting ground waves. The power controller can integrate multiple

power sources namely the grid power supply that is also used to energize the fence and the power from the backup sources including the battery pack and the solar panel. The power controller down converts and regulates the power for supplying constant voltage required by the IoT board. In times of power failures, the supply will switch to one of the backup sources. In the prototype implementation, a rechargeable 12v Li-Ion battery pack has been used as the backup power source that is charged either by the grid power or the solar power depending on the availability. This arrangement would maintain the system active even in times of power failures. Footfalls of various animals measured using geophone sensor was shown in fig 2

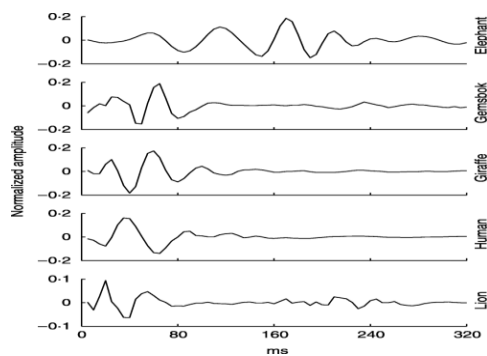

Fig 2 Footfalls using Geophone Sensor

The sensor network will have an array of seismic sensors such as geophone sensors, which can detect movements of large animals like elephants. The effectiveness of the sensor network can be improved by integrating additional sensors which can detect elephants and their movements. The software system will receive telemetry data from the sensor network and detect possible elephant intrusions. It will then send alerts via mobile networks to subscribers and trigger buzzers/alarms positioned in the target area. Fig 3 and fig 4 shows the prototype model and assembled prototype for testing the animal detection.

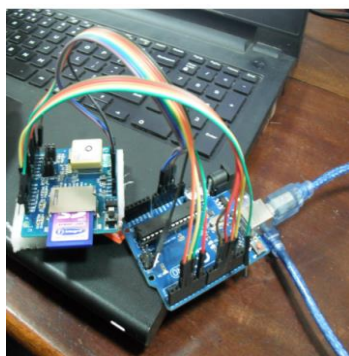

Fig 3 Prototype of Elephant Detection System



Fig 4 Assembled Prototype

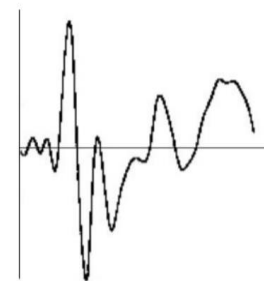

Fig 5 Signals Received and Alerts Public

Elephant walking sound was simulated at 5 meters distance from the prototype installed. The signals received from the model was shown in fig 5. Working prototype detects animal intrusion, send SMS and alert public .In future this approach needs to be tested with real presence of elephant in forest.

#### 4. IoT ENABLED 3 LAYER PIEZOELECTRIC VIBRATING SENSOR DETECTION SYSTEM

Ms Gayathri et al [2] has designed a system consists of three consecutive layers to avoid human animal conflict. Piezoelectric vibrating sensor deployed in first layer was kept at particular distance away from conserved area. Elephant or any object comes near the sensor, its vibration detected by the sensors will identify their type. On detecting the animal presence sends signal to the microcontroller. The workings of sensor in each layer are as follows

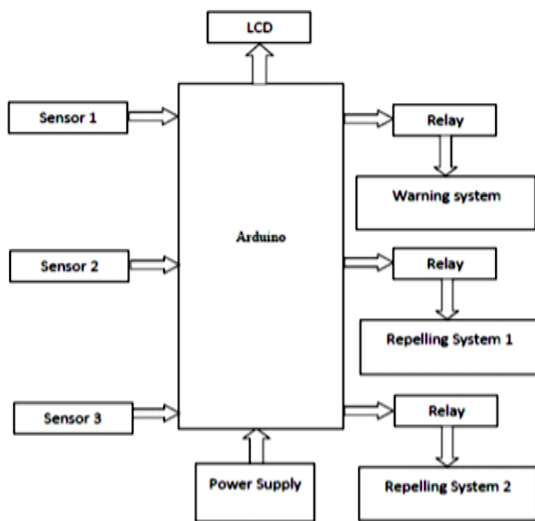

Fig 6 Working Prototype of IoT Enabled Three Layer Piezoelectric Vibrating Sensor Detection System

- Sensor1: It conforms the presence of elephants and its fairly accurate distance from the conserved area, message gets displayed in LCD and warning system switched ON and alert public by sending SMS.
- Sensor 2: Still if elephants present, displays in LCD and switch on Repelling System2 produces sounds of tiger/honey bee and threatens elephants
- Sensor 3: Even if elephants don't repel, displays in LCD and Switch on Repelling System3 and deep smoulder spreads in the region. The smell created by the smoke will distract the elephant's attention and repels back from that area.

#### 4.1 Sensors Deployment

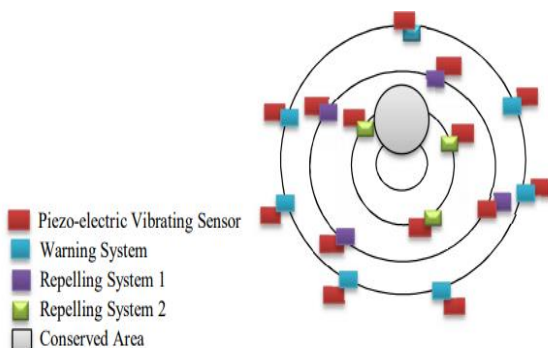

Fig 7 Sensor Deployment

Piezoelectric Vibrating Sensors [15] deployed in three layers was shown in above fig 7. Working of sensors was discussed

#### 4.2 Experimental Setup

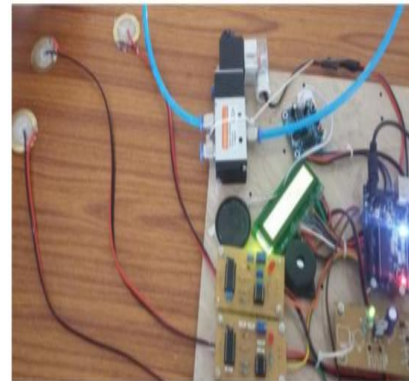

Fig 8 Interfacing Piezoelectric Vibrating Sensors with Microcontroller

Piezoelectric plates s1, s2, s3 connected to sensors was shown in the above fig 8. Analog productivity obtained from sensors sequentially given to microcontroller which aids to check the data and buzzers alarm when required as shown in below fig 9.



Fig 9 Warning Systems Interfaced with Microcontroller

Vibration range detected by sensor less than 400, buzzer will produce the alert and LCD displays the corresponding status and voltage produced. In future the system can be enhanced by altering the threshold value to distinguish other animal intrusions. In future this working model can be attached with Sound Navigation and Ranging which works by echoing sound waves from the obstacle able to predict the space between any type of animal and conserved region.

#### 5. ANIMAL INTRUSION AND DETECTION SYSTEM

In this section, the author Mr. Abhay Sharma[3] discusses animal intrusion and detection system which acts as an alternate for electric fence. This system was field tested in a small village, called Kyari, near Jim Corbett National Park where farmers are threatened by wild animals and lost their lives. This system works similar to a scare crow and makes use of Active Infrared and Passive Infrared Sensors [20] to detect any animals. Alarm triggered by electrical signals, keeps away the elephants entering the fields. The alarm uses a combination of light and sound.





Fig 10 Working Model of Animal Intrusion and Detection System

As shown in the above fig 10, it is evident the system is solar powered. Two sensors PIR Sensors put together covers a diameter of about 30 meters. As soon as animals are detected, automatically tells their location by flashing spotlight and triggers alarm system. This aids the farmers and forest rangers the intrusion of animals. As time moves away the animals gets practiced with the alarm sounds. To overcome this disadvantage, the author has programmed the system in such away it produces combinations of light and sound patterns that changes every time an intrusion is detected. This will delay habituation in animals.

**5.1 Results**



Fig 11 Detects Elephants Intrusion



Fig 12 Elephants Repelled Back

As elephant enters the fields as shown in fig 11, the system detects animal intrusion successfully. First light is flashed and then rings the alarm, the frightened elephant was repelled back into the forest was shown in fig 12. The graph shown below in fig 13 depicts the results of various types of animal intrusion detection and repulsion handled by the system.

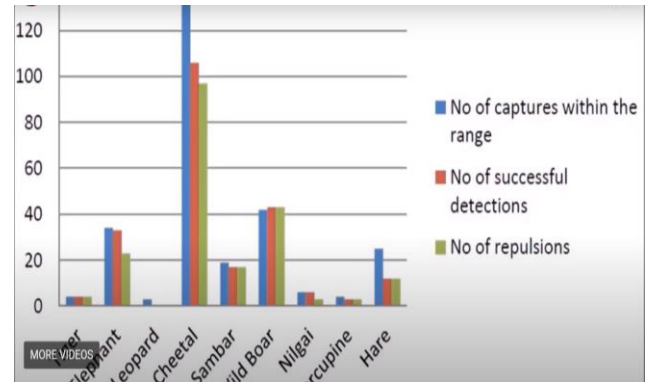

Fig 13 Graph Showing Various Animal Intrusion Detection and Repulsions

**6. IoT SMART ELECTRIC FENCES**

In this approach the author Namal Jayasuriya et al [9], shows how normal electric fence once broken needs human intervention to manually detect the broken area of fence and repair it. The cost-effective smart electric fence, with small IoT nodes placed along the wire can communicate with the same wire as shown in below fig 14.



Fig 14 IoT Smart Electric Fence

Packets are encoded into the high voltage electric pulses identify which node is disconnected from the network. SMS alerts were sent to the crew of people the exact location of the fence brakeage and repairment was done.

**CONCLUSION**

The table given below 1.1 compares the various approaches for IoT Enabled smart solutions to avoid human animal conflicts. In future a similar prototype can be developed

which combines all the features discussed in the previous sections of this paper.

**Table -1:** Comparison of IoT Approaches to Avoid Human Elephant Conflicts

Approaches	Detects Animal Intrusion	Action Taken	Repelling system	Inter module communication	Sensor used	Power source
Approach 1	Yes	SMS alerts	No	No	Geophone, Seismic sensors	Solar Panel, Main Power, Battery Pack
Approach 2	Yes	1.SMS Alerts 2.Sounds of Honeybee and tiger 3.Produces Heavy Smoke	Yes	Yes	Piezoelectric vibrating Sensor	Main Power Supply
Approach 3	Yes	Light and sound alarms	Yes	Yes	Active Infrared and Passive Infrared Sensors	Solar Panel
Approach 4	Yes	SMS alerts	No	Yes	IoT nodes	Main Power supply

**REFERENCES**

- Mohamed Fazil and Mohamed Firdhous, "IoT-Enabled Smart Elephant Detection System for Combating Human Elephant Conflict", 3rd International Conference on Information Technology Research (ICITR), December 2018.
- Gayathri R , Sheela Sobana Rani K and Lavanya R, "An Automatic Repelling System to Reduce Human Elephants Conflicts Using Sensors", International Journal for Research in Applied Science and Engineering Technology, Volume 5, May 2017.
- Abhay Sharma, "Human Wildlife Conflict Tech Challenge: Asian Elephant Case", An article from Wildlabs.Net (The Conservation Technology Network), June 2017.
- Fernando P, "Managing Elephants in Sri Lanka: Where we are and where we need to be," Ceylon Journal of Science, Volume 44, Issue No. 1, pp. 1–11, 2015.
- Asimopoulos S, "Human-Wildlife Conflict Mitigation in Peninsular Malaysia: Lessons Learnt, Current Views and Future Directions," Master's thesis, Department of Urban and Rural Development, Swedish University of Agricultural Sciences, Uppsala, Sweden, 2016
- Bhagat V K, Yadav D K, and Jhariya M K, "Human-Elephant Conflict and its Consequences: A preliminary Appraisal and Way Forward," Bulletin of Environment, Pharmacology and Life Sciences, Volume 6, Issue no. 7, pp. 85–94, 2017.
- Sooriyabandara M G C, "A Game Theoretic Scrutiny to Human Elephant Conflict," Journal of the Department of Wildlife Conservation, Volume 2, pp. 29–40, 2014.
- Baishya, S. Dey, A. Sarmah, A. Sharma, S. Gogoi, T. Aziz, D. Ghose, and A. C. Williams, "Use of Chilli Fences to Deter Asian Elephants - a Pilot Study," Gajah Journal of the Asian Elephant Specialist Group, Vol. 36, pp. 11–13, 2012.
- Namal Jayasuriya, Asanka Sayakkara, Chathura Suduwella, Chamath Keppitiyagama, Kasun De Zoysa, Kasun Hewage and Thiemo Voigt, "Wire is not dead": Wired-backscatter Communication for Breakage

Detection in Electric Fences", International Conference on Embedded Wireless Systems and Networks (EWSN), Pages 300–304, February 2017.

- Leimgruber P, Gagnon J B, Wemmer C, Kelly D S, Songer M A, and Selig E R, "Fragmentation of Asias remaining wildlands: Implications for Asian elephant conservation," Animal Conservation, vol. 6, pp. 347–359, 2003.
- Asimopoulos S, "Human-wildlife conflict mitigation in Peninsular Malaysia: Lessons learnt, current views and future directions," Master's thesis, Department of Urban and Rural Development, Swedish University of Agricultural Sciences, Uppsala, Sweden, 2016.
- Kopnina H, "Wild animals and justice: The case of the dead elephant in the room," Journal of International Wildlife Law & Policy, vol. 19, no. 3, pp. 219–235, 2016.
- Van Eden M, Ellis E, and Bruyere B L, "The influence of human elephant conflict on electric fence management and perception among different rural communities in Laikipia county, Kenya," Human Dimensions of Wildlife, vol. 21, no. 4, pp. 283–296, 2016.
- Hedges S and Gunaryadi D, "Reducing human elephant conflict: Do chillies help deter elephants from entering crop fields?" ORYX The International Journal of Conservation, Vol. 44, Issue no. 1, pp. 139–146, January 2010.
- Ragurama Krishnan M, Sasi kumar S, Syed Ali Mahadeer A, Bharathidasan S, "An Automated System for Identification of Wild Animals and Reduction of Human-Animal Conflicts Using Various Sensors", International Journal of Research in Electrical Engineering", Volume 05, Issue 01, pp.1-4, January 2018
- King LE, Douglas-Hamilton I, Vollrath F, "Beehive Fences as Effective Deterrents for Crop-Raiding Elephants: Field Trials in Northern Kenya", African Journal of Ecology, Volume 49, Issue 04, December 2011, pp.431–439.
- Richard Hoare, "Lessons From 20 Years of Human-Elephant Conflict Mitigation in Africa", Human Dimensions of Wildlife An International Journal, Volume 20, Issue 4, July 2015.
- Alexandra Zimmermann, Tammy E. Davies , Nandita Hazarika , Scott Wilson , Joydeep Chakrabarty , Bhaben Hazarika and Dhruba Das, "Community-Based Human-Elephant Conflict Management in Assam", Gajah Journal of the Asian Elephant Specialist Group, Vol. 30, pp. 34–40, 2009.
- C.K. Rohini, T. Aravindan, K.S. Anoop Das and P.A. Vinayan, "View of Status of conflict Mitigation Measures in Nilambur, Western Ghats of Kerala, India ", Journal of Threatened Taxa, Volume 9, Issue 12, December 2017
- Vivek Thuppil and Richard G Coss, "Playback of felid growls mitigates crop-raiding by elephants Elephas maximus in southern India " , ORYX, Fauna and Flora International Journal, Volume 50, Issue 2, pp.329–335, 2016.