

# IMPLEMENTATION OF MOTION AND PRESENCE SENSOR BASED SMART SLIDING DOOR

Peter Obinna Mbamaluikem<sup>1</sup>, Udoh James Uwem<sup>2</sup>

<sup>1</sup>Lecturer, Department of Electrical/Electronic Engineering, Federal Polytechnic, Ilaro

<sup>2</sup>Technologist, Department of Electrical/Electronic Engineering, Federal Polytechnic, Ilaro

\*\*\*

**Abstract** - To reduce the difficulty and unnecessary delay experienced by physically challenged and elderly people when entering/exiting a facility through a door, a motion and presence sensor-based smart sliding door was implemented. This project includes a sliding door, motion and presence sensors, a brushless motor, a microcontroller to accept data from the sensors for monitoring human movement and controlling the sliding door opening and closing, and a solar PV to ensure electrical power supply continuity. The width/distance covered by the sliding door opening is 75 cm. The motor's operating speed is 22.9 cm/s, and its wattage at fast and slow opening is 11.25 W and 6.63 W, respectively. The detection range of the motion sensor is 3 m, and the total transit time is 3270 ms. After testing, the performance of the implemented system met design specifications, and it can be used where there is no grid power supply.

**Key Words:** Microcontroller, motion Sensors, Presence sensors, solar PV, brushless motor, sliding door.

## 1.INTRODUCTION

Modernization in technology is frequently necessitated by man's desire to advance in life and achieve things easily, thereby improving human comfort and reducing stress [1]. As a result of technological advancement, every aspect of human life has improved in some way over the years. Automatic doors are just one of many examples of man's inventions to improve his or her day-to-day life comfort [2]. People enter and exit buildings through doors on a regular basis. However, the ease of accessing a facility through the door is determined by the type of door installed and the level of automation provided. If the door is manually operated, it will require human effort to push or pull the door open or closed, as the case may be. As a result, physically disabled individuals, people carrying heavy loads, and small children would have difficulty accessing such facilities. Furthermore, in the event of an outbreak of contagious diseases such as COVID-19, the manual method of opening a door facilitates the spread of such diseases. More specifically, in public places (airports, hotels, and restaurants) where there is a high volume of human traffic entering and leaving the facility in rapid succession, the staff who manually open and close the door must perform a significant amount of work. When the door is operated

automatically, the effort required to push or pull the door open is reduced, as is the rapid spread of contagious diseases, necessitating the use of smart systems.

Motion and presence detection is becoming increasingly important due to its broad range of applications, which includes the design of intruder alarm systems, home automation systems, energy efficiency systems, human/animal presence detection systems, object detection systems, and so on [3]. A smart sliding door with motion and presence sensors is a movable door that typically includes a motor, a linear slide rail, and an activation system to open and close the entrance to a building or room where it was installed. This system detects human presence and grants access to the individual without the individual's intervention. Furthermore, the presence sensor detects the presence of a person inside the door, which controls the system's ability to close the door. Automatic doors, in general, behave differently depending on the environment in which they were installed and how they were programmed. If it is installed in a public structure, for example, it will be opened to anyone who approaches it; however, if it is installed for private use, access will be restricted based on its integrated security control mechanism [1].

Over a decade, the desire to make things self-moving and self-controlled was realized. There are numerous ways to make a device or machine smart. To that end, [2] designed and implemented an automatic gate using a microcontroller. [4], created a gate control system that authorizes vehicular access through a gate based on the driver's face and vehicle plate number using the model of an intelligent gate controller with PIC16F84A program using "miKroBasic pro for pic." Furthermore, [5] controlled a gate using a vehicle license plate number. MATLAB, Proteus, and Micro C were used to create the system and an automatic security gate with a keypad that makes decisions based on an RF transmitter-receiver pair. More so, [6] developed an infrared-sensor-based automatic sliding door system. Finally, [7] implemented an automatic door with room light control. Other related literature can be seen in [8][9]

Against this background, this paper designs and implemented a smart sliding door for ease of access into any facility where it is installed using a combination of presence and motion sensors.

## 2. SYSTEM DESIGN

The development of a smart system for controlling the movement of a door as a person(s) approaches the facility where the door is installed was involved in the design of Motion and Presence Sensor Based Smart Sliding Door (MPSBSSD). This work entails designing a sliding door using standard door measurements, driving the door assembly back and forth with a brushless motor, and using a solar power source to ensure the continuity of the electric power supply and thus the door's continuous operation. The detection of presence of users by the motion and presence sensors, and the subsequent control of the doorway by the microcontroller was arranged to take over the manual control of the doorway. To accomplish this, a microcontroller was programmed to accept data from motion and presence sensors in order to monitor human movement and, as a result, control the sliding door. As a result, when the microcontroller receives a signal from the sensors, it processes it and sends a command to the driver system, which is powered by a brushless electric motor, to open or close the door. The system is made up of both hardware and software. The hardware components include the sensor unit, driver system, microcontroller module, and power supply unit, while the software includes the assembly language. The block diagram of the entire system is depicted in Figure 1.

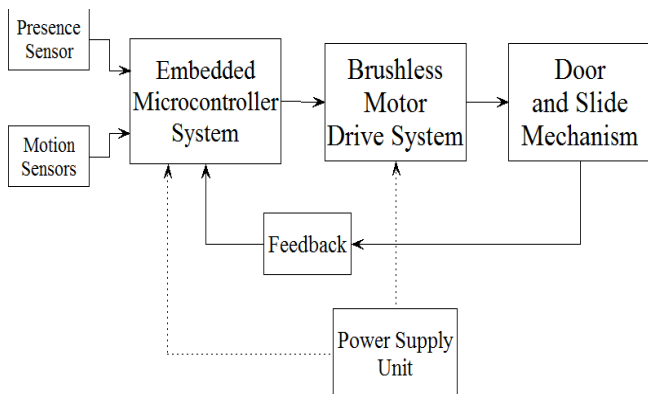

Figure 1: Block Diagram of the MPSBSSD

### 2.1. Embedded Control System

The control circuit is designed using PIC16F876 microcontroller, and it requires 5 V to operate. Figure 2 and Figure 3 depict the embedded control system circuit diagrams of the regulated 5 V Supply and the Control Circuit respectively. The power supply unit

The control circuit is powered by a PIC16F876 microcontroller and operates at 5 volts D.C. The embedded control system circuit diagrams for the regulated 5 V supply and the Control Circuit are shown in Figures 2 and Figure 3. The microcontroller, drive system, and control mechanism are all powered by the power supply unit. When the sensors are activated, they send signals to the control mechanism, which processes them and uses the output to trigger the driver system, which drives the load (sliding door) accordingly.

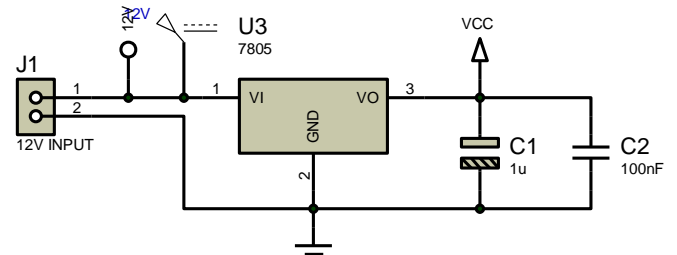

Figure 2: Regulated 5 Vdc Supply for Controller

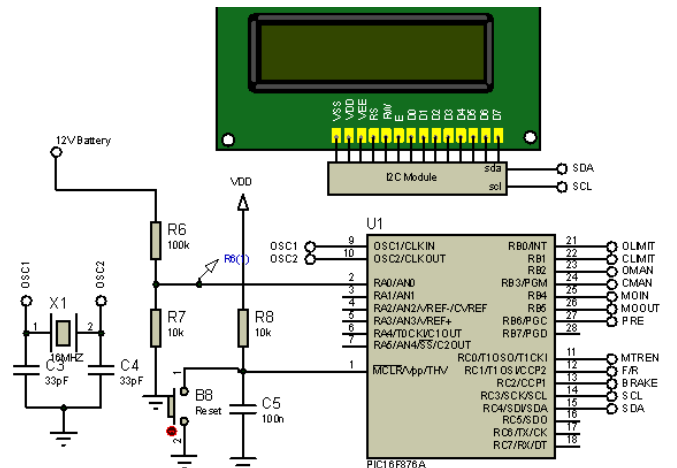

Figure 3: Main Control Circuit Diagram

In addition, the control system has three ports: PORTA, PORTB, and PORTC. Furthermore, PORTA - analogue input port - is used to receive and measure analogue values (battery voltage), whereas PORTB and PORTC are full digital input and output pins used to read selection buttons, motion sensor signals, and presence sensor signals. PORTB and PORTC were also used to tap motor control signals. The controller was programmed with a 20 MHz oscillator to ensure that the speed of operation is fast, thereby eliminating response delays. Figure 4 depicts the software control flowchart.

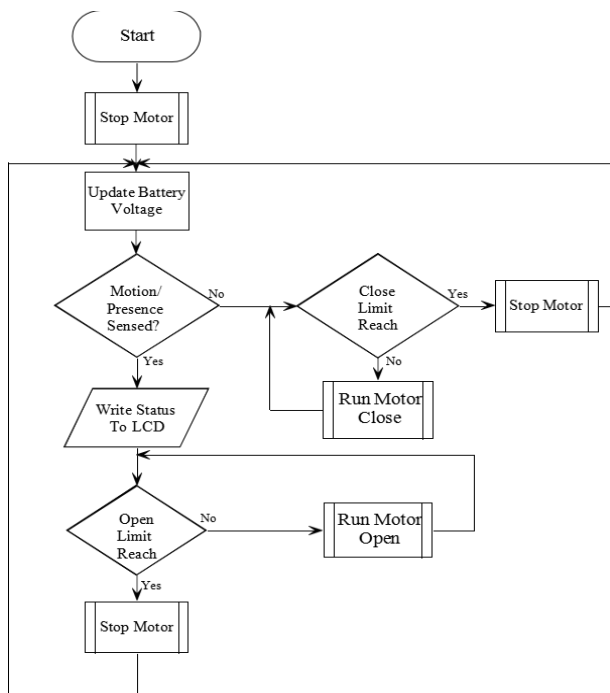

Figure 4: Control Flowchart

## 2.2. Brushless Motor Drive System

To eliminate the wears associated with the brush, a brushless DC motor (Figure 5) was used to drive the slide mechanism. Furthermore, a versatile Brushless (BLDC) motor controller was used to control the voltage and current in the 3-phase BLDC motor equipped with a Hall Effect sensor. A rotor position decoder controls the commutation sequence, a fully accessible error amplifier, a pulse width modulator, a comparator, three open collector top drive outputs, and three high current totem pole lower driver outputs for switching power MOSFETs are all part of the controller. The drive circuit is also centered on a high efficiency monolithic controller – the MC33035.

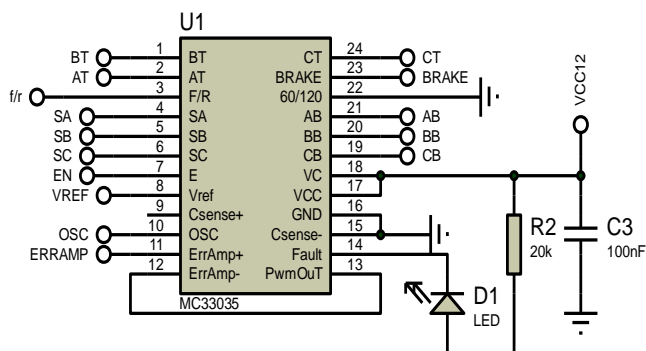

Figure 3: Brushless Motor Drive Controller

## 2.3. SENSOR UNIT

The motion detector employs a variety of sensors, including passive infrared sensors (which detect motion using the person's body heat), microwave sensors (which detect motion by measuring the change in frequency from the produced beam), and ultrasonic sensors (it produces acoustic signals which will detect the motion of a person).

The sensor unit in this work consists of two motion sensors and a presence sensor. The motion sensors are to detect the motion of a person within its range of detection and give the corresponding output signal to the microcontroller. In this study, a microwave motion sensor with a scanning frequency of 24 GHz was used, which operates on the Doppler Effect principle (the production of a change in frequency during a relative motion between a wave source and the observer). It has an integrated face cover design, and long sensing scanning distance up to 2 meters for single side and it uses an intelligent background learning system that can automatically adapt to the different reflective materials on the opposite background making it suitable for installation and use in various environments. Meanwhile, the presence sensor, detects the presence of a person inside the door. The microcontroller uses the signals from this sensor to ensure that the door remains open as long as a person is inside. The picture of the microwave motion sensor and presence sensor are shown in Figure 6.



Figure 6: Motion Sensors and Presence Sensors

## 2.4. FEEDBACK UNIT

The feedback system is made up of position sensors, which are a collection of precision limit switches. The limit switches are activated as the door approaches its open or close position, and a command is sent to the microcontroller to stop the motor.

## 3. DESIGN CONSTRUCTION

The entire door was built with an Aluminum frame and mounted on a metal sheet stand with a thickness of 10 mm, measuring 18.3 m x 4.8 m x 1.2 m. The door's movable portion was hinged on two rollers at the ends. The door driver (brushless DC motor) and control system were enclosed to improve the design's aesthetics. The motor's output power was transmitted to the door via a belt. The presence sensor was installed in the middle of the left door frame. This prevents the motor from closing while someone is still in the way. The motion sensors were installed on the outside and inside of the door, respectively, at the uppermost right and left ends.

The motor and control unit were powered by a 12 V, 100 Ah battery, which was recharged by a 150 W PV module. Figure 7 depicts the Smart Sliding Door setup with motion and presence sensors.



**Figure 7:** Setup of the Constructed Prototype of the MPSBSSD

#### 4. SYSTEM TESTING

Several performance tests were performed on the door to ensure that it functions as intended. Several people entered and exited the system to test the efficiency and effectiveness of the entire system's operation. As a result, the speed of operation during the testing operation is 2.29 m/s, and the wattage of the motor at its fast/slow opening is 11.25 W and 6.63 W, respectively. The detection range of the motion sensor is 30 cm, and the total transit time is 3.270 s. The charging of the battery was monitored on a regular basis to ensure that appropriate charge levels were maintained throughout the testing period.

#### 5. CONCLUSIONS

A smart sliding door employing motion and presence sensor has been designed and implemented for easy access into a facility. This door, which is powered by electricity from the PV module, can be installed anywhere, regardless of the state of power generation and supply. The system's performance after testing met the design specifications. The general operation and performance of the work are dependent on the presence of a person(s) and how close the person is to the door.

#### Acknowledgement

The authors appreciate the financial support of TETFUND through Federal Polytechnic Ilaro.

#### REFERENCES

- [1] G. S. Lakshmi and G. A. Kumari, "Intelligent Automated Sliding Door Robot Control System," *Int. J. Comput. Tech.*, vol. 3, no. 4, pp. 42-50, 2016.
- [2] J. Enokela and M. N. Tyowuah, "An electronically controlled automatic security access gate," *Leonardo J. Sci.*, vol. 2014, no. 25, pp. 85-96, 2015.
- [3] O. Shoewu and S. O. Olatinwo, "Design and Implementation of a Microcontroller Based Automatic Gate," *African J. Comput. ICT*, vol. 6, no.

- 1, pp. 21-32, 2013.
- [4] P. A. Adewuyi, M. O. Okelola, and A. O. Jemilehin, "PIC Based Model of an Intelligent Gate Controller," *Int. J. Eng. Adv. Technol.*, vol. 2, no. 3, pp. 601-605, 2013.
- [5] A. U. Ahmed, T. M. Masum, and M. M. Rahman, "Design of an Automated Secure Garage System Using License Plate Recognition Technique," *Int. J. Intell. Syst. Appl.*, vol. 2014, no. 2, pp. 22-28, 2014.
- [6] O. Oladunmoye, "DESIGN AND CONSTRUCTION OF AN AUTOMATIC SLIDING DOOR USING INFRARED SENSOR," *Comput. Inf. Syst. Dev. Informatics Allied Res. J.*, vol. 5, no. 4, pp. 1-14, 2020.
- [7] H. M. A. Alawad and E. M. Hussein, "A DIGITAL AUTOMATIC SLIDING DOOR WITH A ROOM LIGHT CONTROL SYSTEM," *Int. J. Sci. Res.*, vol. 6, no. 2, pp. 1-4, 2017.
- [8] J. A. Enokela and M. N. Tyowuah, "An electronically controlled automatic security access gate," no. 25, pp. 85-96, 2014.
- [9] N. P. N and N. I. I, "Design and Implementation of Microcontroller Based Security Door System ( Using Mobile Phone & Computer Set )," *J. Autom. Control Eng.*, vol. 1, no. 1, pp. 65-69, 2013.