

Study and Crash Simulation of Underride Guard in Trucks and Trailers

Dattaraj Raikar¹, Vignesh Banjan²

¹Undergraduate, University of Wolverhampton

²Undergraduate, University of Wolverhampton

Abstract - Crash energy absorption of Underride Guards that is present in trucks and other heavy vehicles is introduced in this research. This guard acts as a barrier or safety device which is a type of passive safety for other small vehicles. In an occurrence of a crash with the smaller or passenger vehicle, the response from the safety barrier is studied by making a 3d model of the truck and the vehicle. Various safety standards for underride barriers like FMVSS 223 and CMVSS 223 from different countries were studied and the Vehicle crumple zone is explored to know more about its characteristics, the key focus is to analyze the reaction of the underride guard rather than vehicle crumple zone. A model of a trailer with an underride guard is inspired from a Stoughton Trailer LLC, it is designed on a 3D modeling software SolidWorks and a crash simulation is carried out on ANSYS software, two types of analysis are performed nonlinear static structural and explicit dynamic analysis, in which the explicit dynamics consist of two setups, 40% overlap and full-frontal crash and prevention of the underride is observed. Studying the stiffness and limits of the underride barrier to avoid deformation in the event of an accident. The results obtained showed that a well-designed stiffer guard structure can prevent Passenger Compartment Intrusion.

Key Words: Underride, Underride Guard, Crash Simulation, Heavy vehicles, Crashworthiness, FMVSS, CMVSS, Explicit Dynamics.

1. INTRODUCTION

1.1 Background Study

Transportation industries were growing on a large scale since the early '20s, truck transport was in form and newer trucks with larger load-bearing capacities were manufactured with increased engine power. Due to higher demands for goods, there was a need to travel faster, and many freeways and highways were constructed. These freeways were open to all types of vehicles including small passenger vehicles like sedans, hatchbacks, SUVs, and two-wheelers. Higher speed limits lead to unexpected braking, trucks having power-full brake systems has precise braking; as well as on the other passenger vehicle has advanced ABS brake systems. The truck is a heavy vehicle with a ground clearance much higher than the passenger car.

In event of urgent braking of a truck, the vehicle traveling behind it has a slight chance that it may collide with the rear-end of the truck. In such cases, there are higher chances of Passenger Compartment Intrusion, wherein the impact area could be the hood or windshield section of the vehicle, in such scenarios, there are higher chances of head and neck injuries or maybe death could occur if the crash is severe [1]. The guard is located at the rear overhang of the truck and is used to prevent vehicle underride and technically it is known as a rear underride guard/barrier and is bolted with the truck chassis. In some of the trucks, this barrier is not stiffer enough to prevent such underride which increases the chances of underride as the vehicle traveling behind it can get rushed into the rear side of the truck causing fatal damage to the driver and passenger. This effect is also determined as Wedge Effect.

According to the report from various traffic safety organizations like IIHS and FARS which is a part of the NHTSA, there has been a rise in the accident between a heavy-vehicle and passenger cars. In 1979, more than 4000 people have died due to such crashes. The fatality cases between 1979 to 1998 were the highest [2].

This paper represents the study and a crash simulation analysis of an Underride Barrier present in large commercial vehicles like trucks, trailers, semi-trucks, etc. with a small passenger vehicle. The safety of the cars and its passenger had developed and gained significance for the vehicle manufacturer and the increasing safety norms from an organization like NHTSA, IIHS, etc. had made a tough competition among various car manufacturers, the testing methods and material design are evolved by considering material selection. New testing parameters such as pedestrian safety test, seat belt test, truck-to-car collision, underride barrier test, etc. are being developed.

1.2 Truck/ Trailer rear underride guard regulations

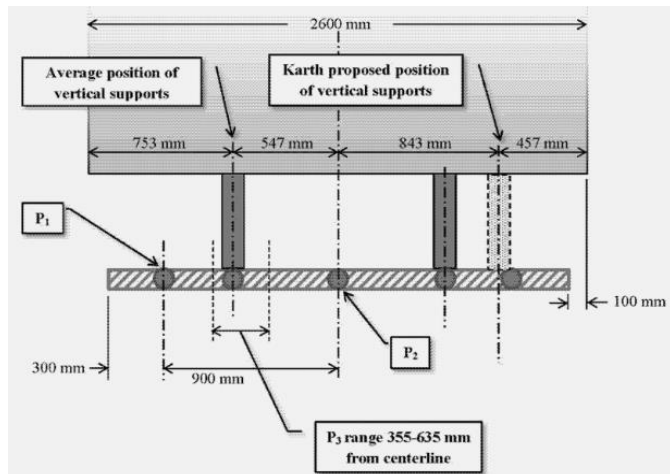

Fig - 1:

<https://www.federalregister.gov/documents/2015/12/16/2015-31228/>

The above underride guard figure comprises of the 2 to 4 vertical pillars and a horizontal pillar at the bottom. The pair of vertical and horizontal pillars form a structure together which is then bolted to the vehicle chassis. The dimension to set the vertical pillars are given above including the load points. A major modification was made by resetting the height from the underride barrier as it was lowered to 22 inches from the ground in the new standards of FMVSS Nos. 223 and 224 which were initiated by NHTSA, these standards were issued in 1953 and further improvement was made in 1998 [3]. NHTSA also collaborated with the University of Michigan Transport Research Institute which collected the data of trucks involved in fatal crashes which have resulted in PCI in 2008 and 2009, more than 3,500 crashes were recorded in which there was a higher percentage of a crash with semi-trailers and passenger vehicles [4]. The CMVSS 223 is the Canadian standard initiated by the Canadian Traffic Department for underride guard in the heavy vehicle it was issued in 2007.

Table - 1: Fatality Report Involving Truck and Car 1975-2019

Year	Number	Percentage
1975	2757	64
1987	3833	70
1990	3790	73
1993	3611	76
1996	3866	77
2004	3693	72
2009	2,223	71
2014	2,486	68
2019	2757	67

The table above shows the crash data collected by IIHS, the problems where the highest number of deaths occurred in 1993 and 1996 due to large trucks.

Table - 2: Underride Crash Fatalities 2008-2017

Year	Fatalities caused by Underride	Overall Large Truck Fatalities	Underride Fatalities as a Percentage of Overall Truck Fatalities (%)
2008	198	37,723	4.66
2010	221	32,999	6.00
2012	247	33,782	6.26
2014	213	32,744	5.45
2015	253	35,485	6.18
2016	196	37,806	4.49
2017	253	37,133	5.31
Average	219	34,663	5.49

This table indicates that **Government Accountability Office** has carried a survey where it was found that out of total truck crashes 5.49% crashed are caused due to underride, marking the higher number of underride fatalities in the year 2012 and 2015 where the number of crashes units are nearly 253.

In this thesis the flat-bed trailer with rear underride-guard is considered an average truck chassis, this model has been designed according to the regulations and standards of **FMVSS Nos. 223 FMVSS Nos. 224** and **CMVSS 223**, guard design has been inspired from the newly revised 2017 Stoughton Trailer underride guards, this guard is chosen because it has provided optimum results in all types of crash tests. The proposed guard has been modified according to the latest requirement and the study of a crash is explained with the help of computer-based crash simulation.

1.3 Car Crumple Zone

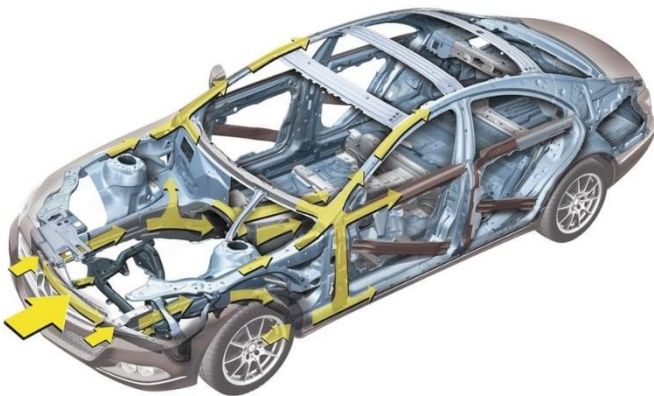

Fig - 2: <https://autoportal.com/articles/safety-technology-in-car-crumple-zone-2807.html>

A passenger vehicle body structure is comprised of a strong core passenger cabin made from composite materials like high-strength steel and the outer structure is designed to absorb any kind of force exerted. The outer structure is mostly added on the front and back of the vehicle, which is also known as crumple zones, they are designed to absorb a majority of impact when a head-on collision occurs. As shown in the above image the yellow arrows represent how the force is been absorbed when the car under frontal impact. The material widely used for the crumple zones is high tensile steel [5]. Modern vehicles manufactured today use high-quality material, they are engineered well to resist any kind of frontal crash as well as side crash. When the underride guard is made stiffer and stronger with lesser deformation in crash test it can save lives of many occupants in the vehicle traveling after the trailer or truck. The focus is to make the barrier stiffer rather than observing the PCI

2. LITERATURE REVIEW

[6] The author had reviewed and compared 3 types of underride barriers 1. "The Articulated Underride Guard", "The Pliers Underride Guard" and "Brazilian Standard Guard", the given barrier types have been tested and their results are analyzed. To validate the underride guards three crash tests were performed. According to the results, in the 2nd of 3rd type of crash tests, the vehicle didn't go beneath the truck/trailer bed. The passenger cabin, steering column, and instrument panel were prevented from being damaged, the design of the underride barrier was so precisely engineered that it cut-shortened the barrier structure from falling far beneath the truck/trailer bed. However, the 1st type of barrier failed to save the passenger as it was not precisely engineered. [7] This study represents the patterns of physical ruptures underride guard, though the speed of vehicle due to which it failed and is inconsiderable. In this research, a series of 6 crash tests were performed to come up with a solution for this issue. As a test subject, various midsized passenger vehicles were provided to make a

collision with the rearmost of the truck/trailer of different manufacturers which was equipped with differently engineered underride protection devices. The results from the above crash test were collected and analyzed for evaluation of good quality underride guard. [8] a study of distortion and energy immersion on a multiple, single, and double wall as well as the circular designed tube is achieved with and without immersion of aluminum foam core, with a purpose to build a better-quality crashworthy component, the author has presented numerical as well as modeling simulation of aluminum foam which is filled in the above stated hollow structures and axial power loading is performed. The results show that it absorbs the shock when the aluminum foam structure is arranged concentrically. [9] this journal defines a newly developed three-dimensional MADYMO structure that is simulated with a car crash test. The underride guard was so engineered that it suppresses the energy effect of a high-speed moving car at 48km/h and 75 km/h and due to high force absorption, there is a drop in the damages caused to the car occupants. The simulation was done to measure the impact to support the project and investigate force-suppression for truck underride guard systems. [10] it represents a newly formed strategy based on "Super Folding Element" theory which derives an overt formulation of pressing force for the consequent columns. When simulated the results showed a positive pact by considering quasi-static trials along with CAE-based simulation, which was performed on LS-DYNA.

3. AIM AND OBJECTIVES

The project aims to show that how a superior quality underride barrier can prevent a collision between a heavy vehicle and a small vehicle e.g., passenger car, to carry a crash analysis and estimate the results that will certify the selection of a better material as well as better underride guard structure that avoids the wedge effect and the keeps passenger intact.

- To perform in-depth research about the truck underride barrier which is used in trucks and other heavy vehicles and study the effect about how they retort to collision with small vehicles.
- To perform broad research about the vehicle's crumple zone that is engineered in vehicles frame which protects the passenger cabin and absorbs the shock.
- By extending the underride barrier height and making it stiffer it can absorb force from the vehicle.
- To evaluate the results that are obtained from the crash test which are performed in analysis software.
- To avoid the wedge effect caused by a vehicle when crashed into the truck/trailer and limit the passenger cabin from getting near to trailer/chassis bed.

4. METHODOLOGY

From the introduction section, it has been discussed how this topic is been selected and further process is presented, when searching for a topic for the Individual Research Project, many topics were considered. The recent rise in accidents due to vehicle underride drew my attention to this topic. After searching for a topic, the rear underride barrier was selected as a topic to work on, in this section of the project the modeling as well the analysis part is explained in detail. Various websites and papers provided data for this research both designs are generated on the same software SolidWorks. Firstly, the analysis part is explained in detail along with dimensions and cut sections. The dimensions and required measurements were taken for the trailer are obtained under **FMVSS No. 223**, **FMVSS No. 224**, and **CMVSS 223** standards for underride guards. As specified above the trailer and the rear underride barrier designed in this paper is inspired from an upgraded version of the Stoughton Trailer which had passed the 2017 rear underride test of 30 % overlap and full frontal crash with a sedan, performed by the **IHS** and has been awarded **TOUGHGUARD [11]**. The car used in this project is made with a dimension of a regular sedan. Further, the 40% and full-frontal offset geometry placement of both the car and trailer are presented in the analysis section.

4.1.1 Truck model-

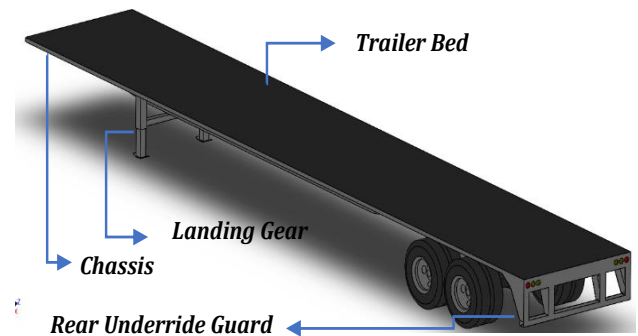

Fig - 1: Isometric View

In this isometric view figure, you can see the detailing of the software is remarkable, we can add as many features as possible in this software. The wheels used are used by making the extrude, extrude-cut, and pattern feature. The trailer bed along with the chassis are modeled with the extrude feature, the underride guard where thickness is used 10 mm for the galvanized steel guard. The landing gear which is the most important part of the trailer is created in this 3D model to give it a realistic look. The length of the trailer is taken as 14,630 mm according to average trailer and height is 1524 mm, the width is set as 2600 mm the rear underride guard dimensions are explained in detail in the figure below [12].

Section	Material	Material properties				
		Density (kg/mm ³)	Shear modulus (MPa)	Young's modulus (MPa)	Poisson's Ratio	Tensile yield strength (MPa)
Trailer	High strength aluminum alloy	2.77e-06	27599	73800	0.337	363
Underride guard	Galvanized steel	7.86e-06	80233	2.07e+05	0.29	314
Car	High strength structural steel	5.87e-06	76923	2e+05	0.3	250

Table - 3: Material Properties according to structure

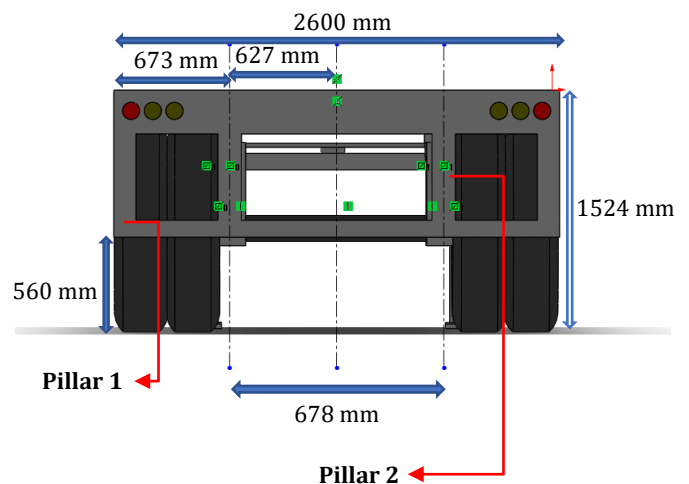

Fig - 3: Rear Underride Guard model dimensions (Back view)

The underride guard which is to be used for analysis is designed with all the calculations set by the traffic and safety authorities, the underride guard pillars P1 and P2 are designed by keeping 560 mm length of the underride guard from the ground. **Pillar 1** is the vertical pillar designed at the outer sides of the guard which acts as a barrier for offset

crash. **Pillar 2** is located at the inner side of the guard to deal with a full-frontal crash. When the Pillar is moved to the outer section of the guard the guard becomes stiffer at the edges, so there are lesser underride chances and **PCI** at the edges.

After the model is completed, the split command is used to cut the trailer into front and rear section sections, where the rear section is used for further analysis. The rear section does not include the wheels, the rear section is then further divided into another two sections. The format of the file is changed from Solid-part to Para-solid format for analysis in ANSYS software.

4.1.1 Car model

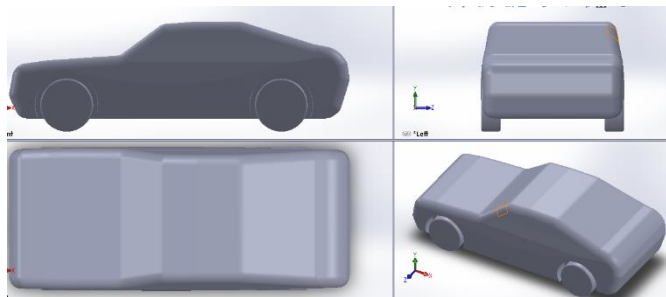

Fig - 4: Car Model

In the above figure the side view, top view, front view, and isometric view are shown. The car model is designed on the SolidWorks software, the dimensions are, height is 1450 mm, length 4650 mm and width is taken as 1780 mm which are realistic as of a regular sedan car, sedan car is designed as most of the passenger's vehicle involved in the crash are sedans. The model was made using the extrude command and the sketch was made on the right plane, to give it a realistic look numerous fillets were added. Afterward, wheels were sketched with an appropriate ground clearance of 165 mm. At this height, the vehicle crash areas (including the crumple zones) are at the correct position to interact with the underride barrier.

After the modeling was done the car was split into front half and rear half, the front half-car was split from the fire-wall section of the car, and it was used for explicit dynamics analysis which is explained in detail in the Analysis section below. The fillet added to the body and wheels were removed and the format of the file was changed to Para-Solid to analyze ANSYS software.

In the analysis section, both the car split section and trailer split section will be added to the analysis Geometry tab, and further analytical information such as Meshing, Pre-processing, and Solver of the above-designed models are explained.

4.2 Analysis

4.2.1 Geometry import of the Truck and Car

Truck-

After the format of the file is changed after necessary changes were made in SolidWorks. In the ANSYS software the geometry was imported in static structural tab with nonlinear analysis, for accurate analysis there was a need to apply appropriate material for the model, which was applied in the Engineering data column. As discussed in the modeling section for analysis only the rear part of the trailer was used, this was done to save time and with less material, the mesh quality can be enhanced by giving it finer mesh. The rear section does not include the wheels. Under the engineering data, the materials were added, for the trailer bed high strength aluminum alloy is used and for the guard section, galvanized steel is selected. By default, the connections in the software are set, as the software automatically detects the joints.

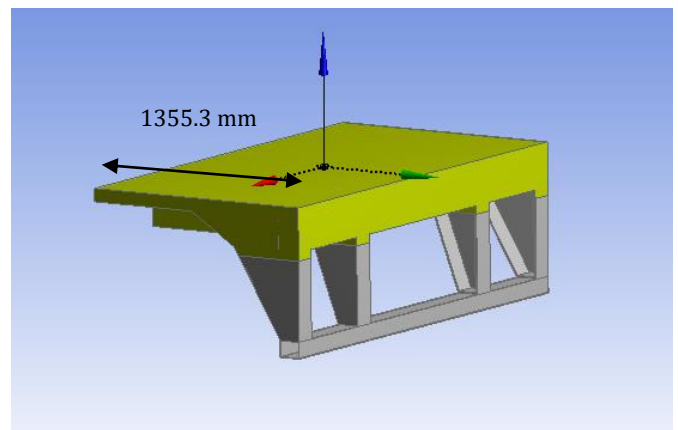

Fig - 5: Rear Cut Section of The Trailer

In this figure, the lower section is split into underride guard and the upper part is the trailer bed which is considered the head geometry. Both the geometries are converted as simplified geometry and simplified topography to generate a good mesh. The Length of this trailer section is 1355.3 mm.

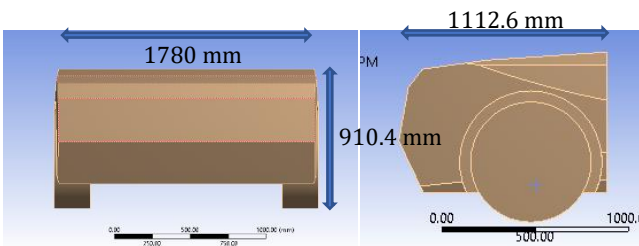

Fig - 7: Front View Car Cut

Fig - 6: Side View Car Cut Section

The model in the image is the front half of the car as discussed in the modeling section, the dimensions are defined in the images, the car split length is 1112.6 mm, the width has not been changed and the height becomes 910.4 mm after splitting the car.

4.2.2 Placement of the model

40% offset

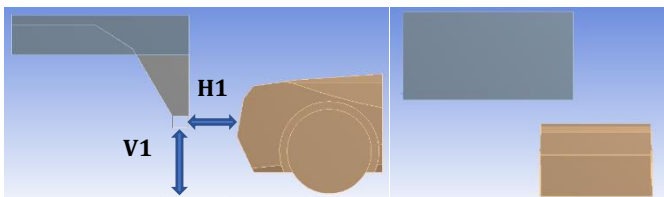

Fig - 9: 30% Side View

Fig - 8: 40% Top View Model Dynamics

In this section, both the car frontal area as well as the trailer rear area is imported in the geometry section. The 40% offset indicates the only the 40% frontal area of the car will meet the trailer end in the event of a collision. The distance between both the structures H1 is kept at 367 mm. The vertical distance between the lowest edge of the underride guard and the lowest point of the wheel V1 is set at 560 mm, which states that the car is at ground level. In the other picture, 40% of the vehicle width is set to collide with the underride.

Full-frontal crash

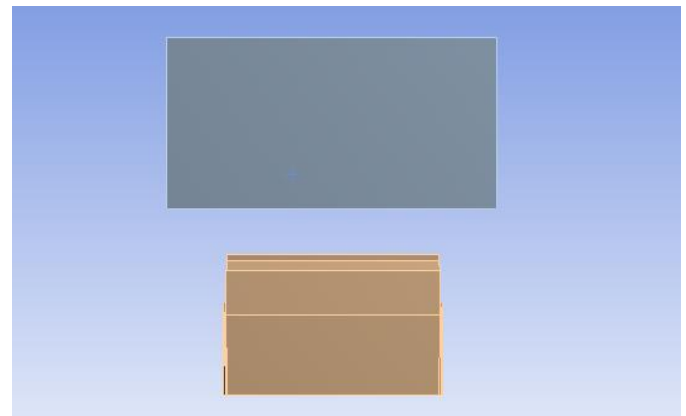

Fig - 10: Full Frontal Top View Model Dynamics

This section defines full frontal collision with the underride barrier of the trailer, as shown in this image, with zero percent of overlap. It means the total structures crumple zones of the car will be utilized to absorb the energy caused by the impact. The material was applied for all the material high strength structural steel material was added to the car structure and for the trailer components, the same material was applied as stated in truck geometry import.

4.3 Meshing

4.3.1 Static structural

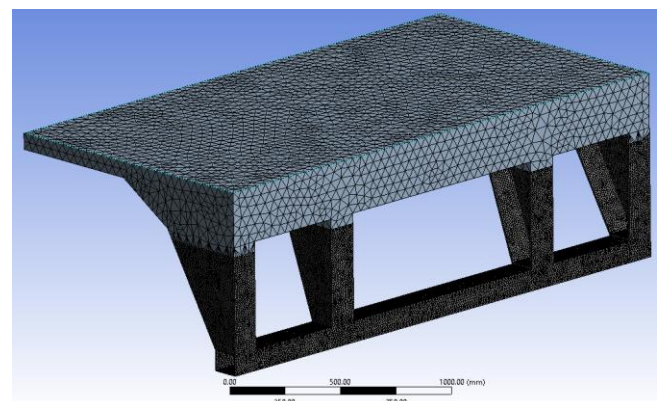

Fig - 11: Truck split Mesh

In the above figure mesh image of the structure is presented. After adding the material for the nonlinear static analysis, the next step is to add a fine mesh to the structure, Tetrahedral mesh structure was applied and the element size was kept at 50 mm, as it can increase the chances of accurate results, the skewness was set to 0.900 which is the difference between cell structure and equivalent volume, it is

considered the skewness should be less than 0.9500 and the Jacobian Ratio set as 0.0400 which is considered a good ratio, the number of cores used were 2 as my system had 2 cores with 2 extra cores for hyperthreading. The total numbers of nodes set were 340084 and the elements were 180893. The inflation was set as a smooth transition along with pinch tolerance set to 0.45 mm as default.

The mesh control was used separately for the underride section using the scoping method where the whole lower section of the trailer is selected, as it will be the main object where the force will be applied for nonlinear static analysis. Finer meshing is applied to that section. The mesh size is applied as 10 mm which is much lesser than the above mesh size with defeature size of the element at 0.25 mm and growth rate of mesh as 1.5. Contact match feature is added to the mesh because there were two joint parts and in the mesh matching operation approx. 228 nodes were paired. This pairing is done to create a balance between both bodies' meshing structures.

4.3.1 Explicit Dynamics

Meshing structure for both types of setups 40% as well as full crash are same, meshing for 40% setup is explained below.

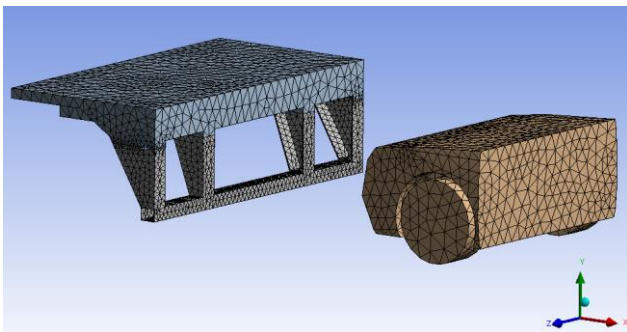

Fig - 13: Meshing explicit dynamics 1

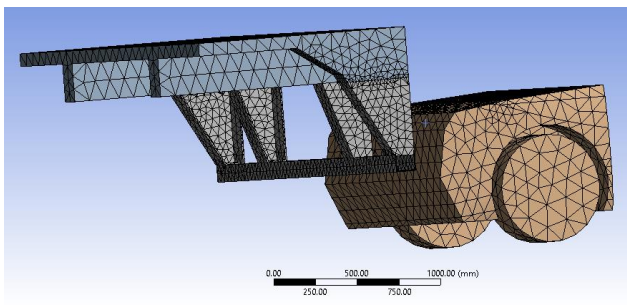

Fig - 12: Meshing explicit Dynamics 2

The same tetrahedral mesh structure is used in this analysis, for this analysis a coarse mesh is used. Overall mesh of 100 mm is used for the trailer chassis and car structure. A finer mesh of 50 mm was applied to the underride part of the trailer by using the body sizing command in meshing. A new form of meshing Face meshing was used on the frontal surface of the car. Mesh defeaturing was enabled along with allowing large deformation. Skewness, Jacobian Ratio was under average conditions. The growth rate for the mesh structure is calculated as 1.2. This meshing had 6779 nodes with 24553 total elements. Contact match was also applied in this mesh where 153 nodes were paired between the upper and lower section of the trailer.

4.4 Pre-processing

4.4.1 Static Structural

In the first part of the pre-processing, the Analysis setting is set according to this analysis, major changes were made. In the table below, the nonlinear data option was enabled to do nonlinear static analysis. The large deflection was enabled to show realistic deformation conditions. Due to there were two objects the contact data was turned on. Other settings were set by default.

Table -1: Analysis Setting

Number of steps	1
Step end time	1.s
Output control	
Contact data	Yes
Nonlinear data	Yes
Large deflection	Yes

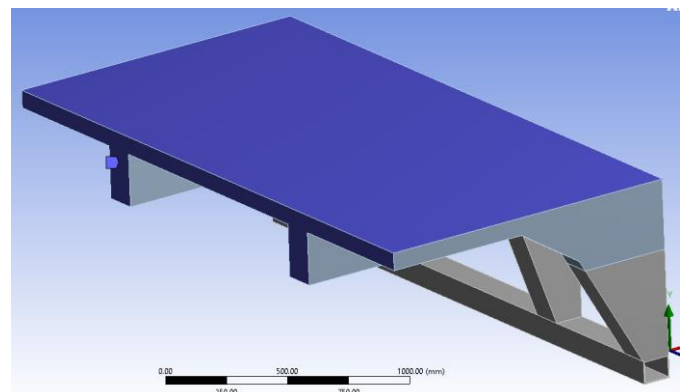

Fig - 14: Fixed Support static structural

In the pre-processing section, various boundary conditions are applied to the structure. In the above figure, the fixed force is applied on the front face, which is the trailer bed, and on the rear face of the chassis, this is done to add fixed support to the structure.

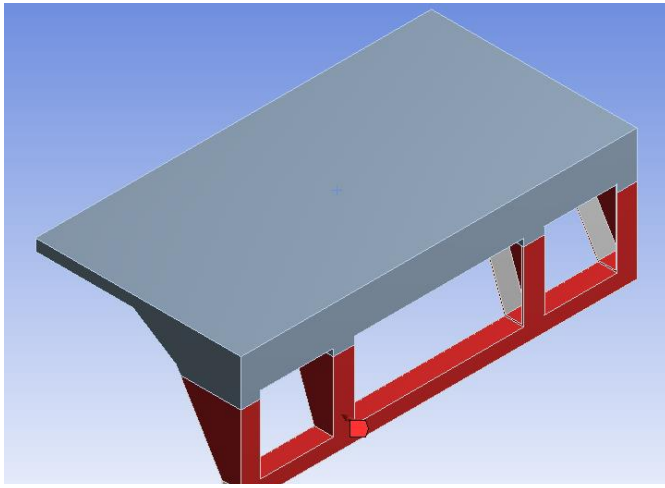

Fig - 15: Direction of Force Applied Static

This image shows the direction of the force added on the barrier, the red arrow shows the direction of the force of 350 k/N, this force is uniformly distributed. This direction is set as the vehicle moving with struck the barrier.

4.4.2 Explicit Dynamics

Pre-processing for both the 40% as well as a full-frontal collision will be the same the only difference will be the placement of the car model. In this part, the velocity of 56 km/h which is 15555.3 mm/s is added to the car and the trailer structure is added with fixed support. Under analysis settings the number of steps is set to 1 second, the end time is set to 0.023 is calculated by dividing the distance between the truck and car structure which is 367 mm with the speed applied. The maximum number of cycles is set to 1e+07, the large deformation is enabled to obtain realistic deformation results. For both explicit dynamic setups, the displacement is added, and it is set to zero value in a vertical direction (Y-direction).

4.5 Solver

4.5.1 Static Structural

In this section of the analysis, various solver inputs were added to get a possible output, it includes the Strain Energy and Total Deformation. The strain energy was added to calculate the energy absorption of the barrier, the Total

deformation was added to calculate the final deformation of the trailer as the force is applied to it.

4.5.2 Explicit Dynamics

In the Solver part, the equivalent stress was selected from the solver input to calculate the deformation that occurred on both 40% and total frontal crashes. After the solver setup was completed for both types of analysis, it was further proceeded to solve.

5. RESULTS AND DISCUSSION

5.1 Static Structural

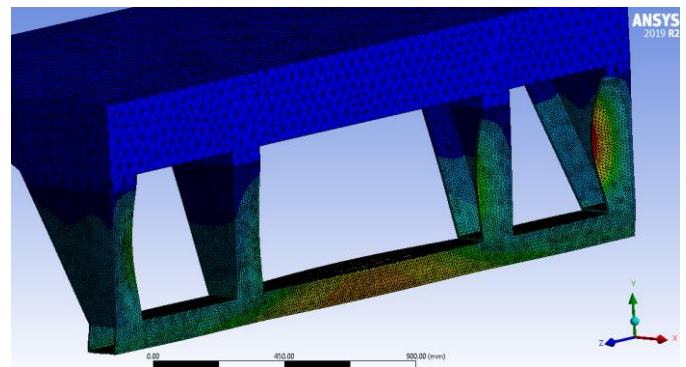

Fig - 16: Total Deformation Static Structural

Now according to the standards of FMVSS 223/224 and CMVSS 223, 35 k/N of uniform load should be applied to the barrier. Then after applying the force the barrier should not exceed 125 mm of deformation. According to CMVSS, 223 energy absorbed should not be more than 20,000 J when the force is set to be applied [13]. So, as the results show the maximum value in the total deformation output is calculated as 2.18 mm which far lesser than the threshold value of 125 mm.

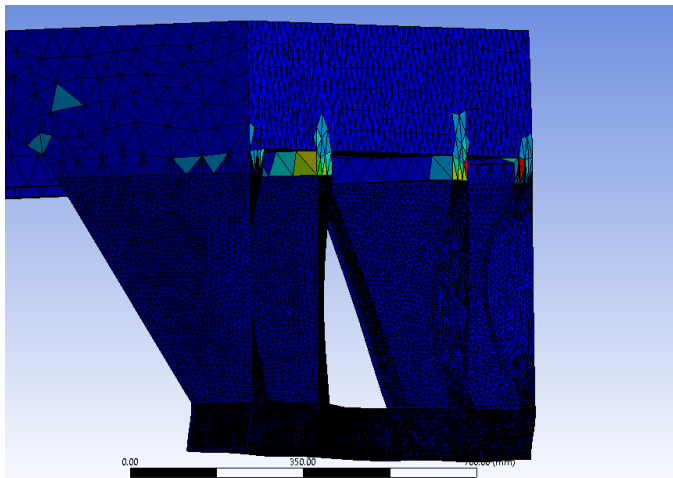

Fig - 17: Energy Absorption

In this figure, the maximum energy absorption is recorded as 196.29 m/J which is approx. 0.19629J and it is considered under a safer limit. These are the regulations which were made by the traffic authorities.

5.1 Explicit Dynamics

5.1.1 40% overlap crash results

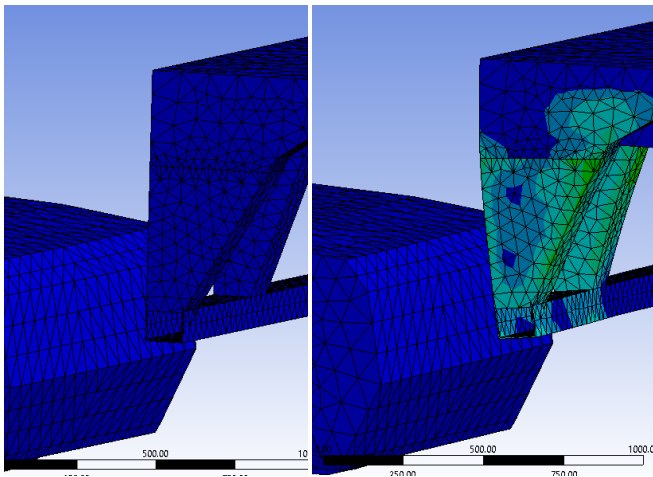

Fig - 18: Before and After Deformation 40%

In this section the images of before deformation and after deformation is presented. As said earlier the car deformation is not considered important, the focus was to strengthen the underride guard structure. When the guards are made rigid and stiffer, they tend to deform less. In this project the car was propelled at 56 km/h and such speed if the guard resist the force, there are more chances of survival of the

passengers. From the results it can be observed that the structure of the underride guard which is inspired by the Stoughton Trailer LLC resists the force of the vehicle, the extra triangular section added at the edges of the guard proved to be effective. Maximum equivalent stress of 13,350 MPa was recorded at the peak point of collision, with an average of 192.5 MPa.

5.1.2 Full-Frontal crash results

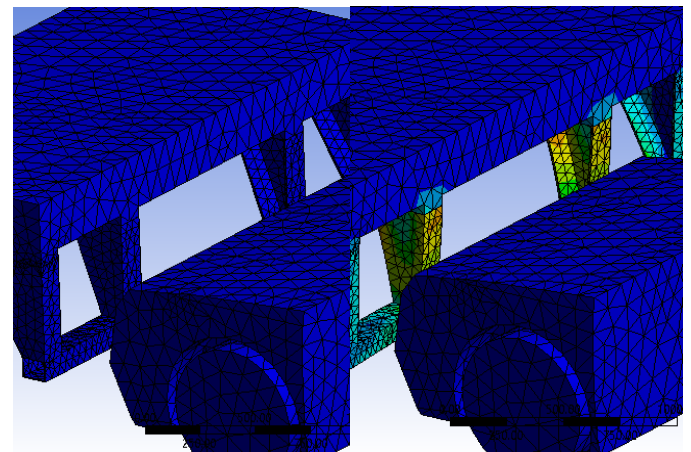

Fig - 19: Before and After Full- Frontal Crash

A full-frontal area crash results are given in this figure; it shows the physical deformation of the barrier when the vehicle is struck at the mid-section of the trailer. The same velocity is used of 56 km/h as used in the 40% overlap. The equivalent stress records maximum stress of 10,343 MPa, by showing minimum deformation. The average stress value on the guard is 138.94 MPa. This shows that the unique vertical pillar design absorbs the load and stops the car from underride. This proof than by stiffer material and good structural design of underride guard can make it stronger.

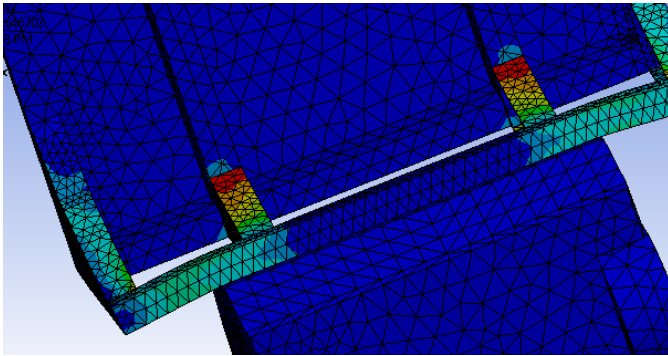

Fig - 20: Full Frontal Crash Bottom View

In this image, the guard pillar can be seen distributing the load, and the triangular section of the pillar is transferring the load to the chassis of the trailer. The passive safety of this trailer has proven effective.

Each of the analyses took more than 4 hours to solve as they were using 2 cores of the CPU.

6. CONCLUSIONS

Traffic safeties need to be enhanced as mainly the trucks and other heavy vehicles can cause sudden accidents due to higher speed, different country regulations for trailer underride guards are explained and standard testing methods are studied. Various fatalities accident reports are presented which involved car underride due to absence or weak underride protection system. The major updates made in such passive safety structures of heavy vehicles are explained. Standard testing methods performed by traffic authorities are used to approve the presented design structure which is designed on SolidWorks software. The key objective of this project is to study how stiffer and stronger underride barriers are used for trucks, by designing one and showing possibilities to avoid underride of passenger vehicles. Various aspects of the analysis, in the form of static and explicit dynamics, are studied. Static and explicit analysis methods are performed practically on a well-known analysis software ANSYS. The dynamic analysis of 40% crash in addition to full-frontal crash, are performed between truck and car. After getting great results, they were explained and studied. Thus, it was declared that with good design a stiffer underride guard can be obtained.

7. Future Scope

As the results proved that a strong structure and good designed Underride guard can prevent fatal vehicles accidents, here the future scope namely is that the crash simulation can be performed on better software that is more inclined towards Implicit and Explicit Dynamics. Softwares

like LS-Dyna and Altair HyperCrash can provide you with a detailed crash simulation by consuming less time and assimilating all the crucial elements of an actual crash test.

REFERENCES

- [1] U. S. G. A. Office, "Truck Underride Guards: Improved Data Collection, Inspections, and Research Needed." <https://www.gao.gov/products/gao-19-264> (accessed May 07, 2021).
- [2] "Fatality Facts 2019: Large trucks," *IIHS-HLDI crash testing and highway safety*. <https://www.iihs.org/topics/fatality-statistics/detail/large-trucks> (accessed May 04, 2021).
- [3] "Heavy-Vehicle Crash Data Collection.pdf." <https://www.google.com/search?client=firefox-b-d&q=Heavy-Vehicle+Crash+Data+Collection.pdf> (accessed May 03, 2021).
- [4] "Rear Impact Guards, Rear Impact Protection," *Federal Register*, Dec. 16, 2015. <https://www.federalregister.gov/documents/2015/12/16/2015-31228/rear-impact-guards-rear-impact-protection> (accessed May 03, 2021).
- [5] J. Holtz *et al.*, "Crashworthiness enhancement of a composite intensive, multimaterial fullyelectric urban car," p. 18 (6 .)-18 (6 .), Jan. 2016, doi: 10.1049/cp.2016.0978.
- [6] J. R. L. Mariolani, "Development Of New Underride Guards For Enhancement Of Compatibility Between Trucks And Cars," p. 11.
- [7] M. L. Brumbelow, "CRASH TEST PERFORMANCE OF LARGE TRUCK REAR UNDERRIDE GUARDS," p. 8.
- [8] M. D. Goel, "Deformation, energy absorption and crushing behavior of single-, double- and multi-wall foam filled square and circular tubes," *Thin-Walled Struct.*, vol. 90, pp. 1-11, May 2015, doi: 10.1016/j.tws.2015.01.004.
- [9] R. Zou, G. Rechnitzer, and R. Grzebieta, "SIMULATION OF TRUCK REAR UNDERRUN BARRIER IMPACT," Oct. 2020.
- [10] S. Reddy, M. Abbasi, and M. Fard, "Multi-cornered thin-walled sheet metal members for enhanced crashworthiness and occupant protection," *Thin-Walled Struct.*, vol. 94, pp. 56-66, Sep. 2015, doi: 10.1016/j.tws.2015.03.029.
- [11] "Stoughton Trailers | Rear Impact Guard." <https://www.stoughtontrailers.com/products/rear-impact-guard> (accessed Nov. 10, 2020).
- [12] "Federal Size Regulations for Commercial Motor Vehicles - FHWA." https://ops.fhwa.dot.gov/freight/publications/size_regs_final_rpt/ (accessed May 06, 2021).
- [13] "PRELIMINARY REGULATORY EVALUATION FMVSS No. 223 Rear Impact Guards and FMVSS No. 224 Rear Impact Protection - Google Search." <https://www.google.com/search?client=firefox-b-d&sxsrf=ALeKk03ucFmpHbflrWwzEXGNrmspFYzFQQ>:

1620416824895&q=PRELIMINARY+REGULATORY+E
VALUATION+FMVSS+No.+223+Rear+Impact+Guards+
and+FMVSS+No.+224+Rear+Impact+Protection&spell
=1&sa=X&ved=2ahUKEwj0jvGJq7jwAhUI7XMBHRvxCs
wQBSgAegQIARAx&biw=1366&bih=654 (accessed
May 08, 2021).