

TRANSMISSION ASSEMBLY IN A QUAD-BIKE: DESIGN, OPTIMIZATION AND ANALYSIS

Aman B. Sharma¹, Ronak R. Sarkar², Omkar R. Totre³, Latika M. Rahate⁴, Gaurav K. Singh⁵,
Ashish A. Jadhav⁶

¹⁻⁶Student, Department of Mechanical Engineering, A. C. Patil College of Engineering, Kharghar, Navi Mumbai, Maharashtra, India

Abstract - The document outlines the stages involved in designing the transmission assembly for an ATV constructed for the FMAE Quad Bike Design Competition. It provides a forum for undergraduate students to apply theoretical underpinnings to a real-world problem in the automotive industry. Simulation and optimization of the design are studied using iterative finite element analysis. Stress, strain, and deformation analysis were all used to examine the components. In order to reduce mass and expense, the entire transmission system was optimized from the previous competition to make the system more efficient, lighter and cheaper. Under the necessary boundary conditions, stress, total deformation, and associated strain were evaluated for each component. Assessing the suspension geometry parameters, identifying and evaluating the obstacles that were associated with paving a path towards the system's final assembly. The design parameters are determined based on judgements or the worst situation on the track, and the parameters are then simulated. Based on all of the simulations, we can conclude that the transmission assembly is safe, although it can be further refined based on the designer. The design procedure follows all the rules laid down by FMAE for Quad Bike Design Challenge (QBDC) Season 6.

Key Words: Transmission Assembly, 6-Ball Joint, 3- Ball Joint, Ball-bearing, Chain Drive, Spool Drive, Sprocket, Gear, ATV, QUAD Bike, SolidWorks 2020, Analysis, FEA, CNC Machining.

1. INTRODUCTION

The Powertrain system, commonly known as the Transmission system, is a critical component of each and every vehicle. A functional transmission scheme is essential for any type of vehicle motion since it turns the engine's power into rotational motion. Previously in QBDC Season 5, we used an open differential as part of the transmission system because it allowed the outer drive wheel to revolve quicker than the inner drive wheel during a turn. The outer wheel, which travels around the outside of the turning curve, rolls farther and faster than the inner one when the vehicle rotates. Even though the differential alleviated the cornering problem, it increased overall weight and maintenance costs.

For the current season, Season 6, the transmission mechanism has been replaced with a spool-based powertrain, rather than a differential. The main reason

to choose Spool drive over Differential is that they are heavier than spool, which increases the mass of the transmission parts due to the increased number of parts in total. Furthermore, the maintenance will be increased. As a result, it is more expensive than the spool. Additionally, if the wheels of a car with an open differential have one wheel on a slippery surface and the other on a good traction surface, the transmission will begin delivering all of the power to the wheel with less traction in the form of high-speed spinning. This disadvantage can be overcome by using a limited slip differential, which directs more torque to the wheel with the best traction. In 2014, Motec data was collected utilizing a locked and unlocked 3 configuration for the Drexler limited slip differential, and it was discovered that the car would actually record faster lap times on an autocross track in a locked system due to lower tyre slide and the ability to accelerate out of corners faster.

2. SPOOL-DRIVE COMPONENTS

The spool drive transmission system is comprised of three major components. These are the Left Spool Flange, Spool Connector, and Right Spool Flange.

2.1. LEFT SPOOL FLANGE

The Left Spool Flange's primary function is to connect the transmission assembly to the left wheel assembly. It also serves as a support for the sprocket, which transfers power from the engine via chains. The final CAD model of the Left Spool Flange was created in SOLIDWORKS and is illustrated in Figures 2.1.1, 2.1.2, and 2.1.3 below. Front and rear isometric views are shown in figures 2.1.1 and 2.1.2, respectively, while the front view of the left spool flange is shown in figure 2.1.3. The design approach for this product was guided by four principles: high strength, low weight, economy, and ease of manufacture.

2.1.1. DESIGN

Designing is one of the most critical aspects of the procedure because any errors can endanger the rider. It is vital to understand the limits associated with those components before creating any form of sketch. The following elements were factored into the

equation while designing an effective left spool flange:

1. Sprocket lobe:

The sprocket mounting spacer made on the spool flange is based on the sprocket's PCD. The sprocket lobe is then formed depending on the sprocket's bolt pattern. This is owing to the fact that the sprocket will be installed on the sprocket lobe.

2. Internal joint:

To connect the combined spool-drive assembly, an internal bolt series connection has been used.

3. CV joint spacing:

The boss is generated on the opposite side of the Left spool flange depending on CV joint movement.

4. CV assembly lobe:

The CV lobe is constructed employing the CV housing bolt pattern. This is owing to the fact that the CV housing will be installed on that lobe.

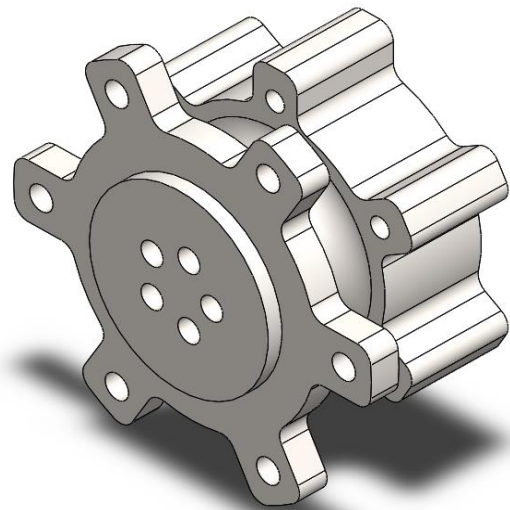

Fig 2.1.1: Front Isometric View of Left Spool Flange

2.1.2. MATERIAL SELECTION

Material selection is the next crucial step in the production of left spool flanges. Because it will help us achieve our goal of boosting strength while decreasing body weight.

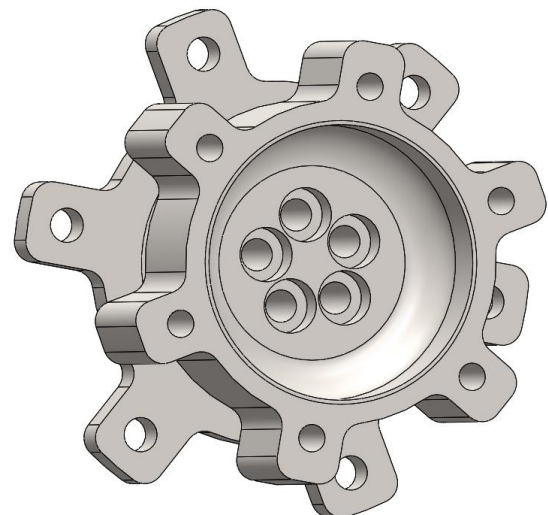

Fig 2.1.2: Rear Isometric View of Left Spool Flange

Property	Al7075	EN 8
1. Young's Modulus (GPa)	71.7	190
2. Density (kg/m3)	2810	7850
3. Poisson's ratio	0.33	0.285
4. Tensile Strength (MPa)	572	580

Based on the above parameters, EN 8 is selected.

2.1.3. ANALYSIS

After the content has been restored, we can continue the analysis. Analysis aids in the identification of excess materials as well as weak points. After we've discovered the problems, we'll go on to the conceptual design stage, in which the component would be redesigned and assessed again.

2.1.4. MANUFACTURING

Manufacturing the part is the very last stage as once safety analysis has been completed. The left spool flange is CNC machined.

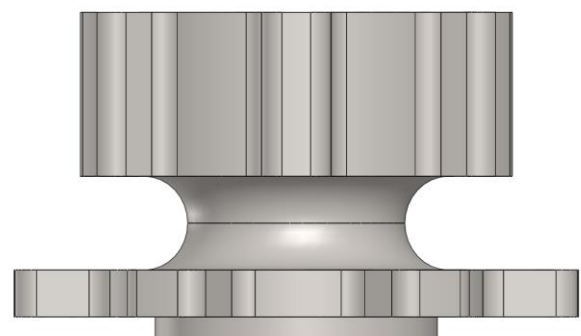

Fig 2.1.3: Front View of Left Spool Flange

2.2. SPOOL CONNECTOR

The spool connector serves as an intermediate link between the two spool flanges. It even aids in the transmission process. Figures 2.2.1, 2.2.2, and 2.2.3 show the finalized SOLIDWORKS CAD model of the

Spool connection. Figures 2.2.1 and 2.2.3 show the front and rear isometric views of the Spool connector, respectively, while figure 2.2.2 shows the front perspective of the Spool connector. The design approach for this product was guided by four principles: high strength, low weight, economy, and ease of manufacture.

2.2.1. DESIGN

Designing is one of the most critical phases in the method, since any mistakes might endanger the rider. Before building any type of drawing, the limitations associated with such components should be recognized. The following limitations aided in the development of a good spool connector:

1. **Bearing Provision:**
The circlip (external retention ring) on one end and the spool connector's body on the other end prevent the bearing from rotating in one direction alone. Because there are bearings on both sides of the spool connector, a comparable configuration is generated on the opposite side.
2. **Internal joint:**
Internal bolt series connections are used to link the entire spool-drive unit.

2.2.2. MATERIAL SELECTION

The spool connector is also made of EN 8, as is the left spool flange.

2.2.3. ANALYSIS

We can begin analysis once the content has been rectified. Analysis aids in identifying extra materials as well as weak points. Once the errors have been identified, we will proceed to the designing stage, where the part will be updated and then analyzed again.

2.2.4. MANUFACTURING

Manufacturing the part is the last stage once the safety analysis has been completed. CNC machining was used to make the spool connector.

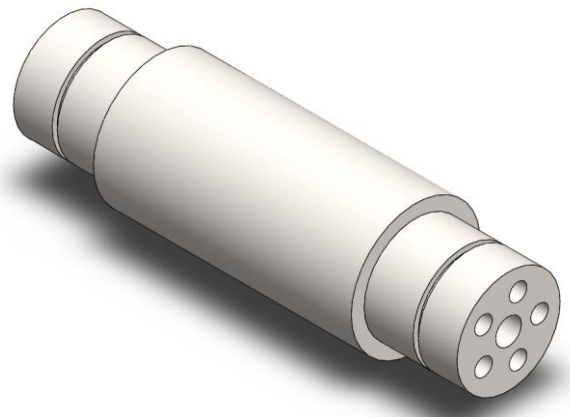

Fig 2.2.1: Front Isometric View of Spool Connector



Fig 2.2.2: Front View of Spool Connector



Fig 2.2.3: Rear Isometric View of Spool Connector

2.3. RIGHT SPOOL FLANGE

The Right Spool Flange's primary function is to connect the transmission assembly to the right wheel assembly. Internal joints are used to connect the transmission assembly as a whole. The final CAD model of the Right Spool Flange was created in SOLIDWORKS and is shown in Figures 2.3.1, 2.3.2, and 2.3.3 below. Figures 2.3.1 and 2.3.2 show the front and rear isometric views, respectively, while figure 2.3.3 shows the front view of the right spool flange. The four guiding factors in the design

process for this product were high strength, low weight, economy, and ease of manufacture.

2.3.1. DESIGN

Designing is one of the most critical steps in the procedure, as any error could endanger the rider. Before constructing any type of sketch, the limits associated with such components must be understood. The constraints that aided in the development of a successful right spool flange are listed below:

1. Internal joint:

An internal bolt series connection is used to connect the entire spool-drive assembly.

2. CV joint spacing:

The boss on the opposite side of the Right spool flange is created based on CV joint movement.

3. CV assembly lobe:

The CV lobe is designed using the CV housing bolt pattern. This is due to the fact that the CV housing will be installed on that lobe.

2.3.2. MATERIAL SELECTION

The right spool flange is also made of EN 8, as is the left spool flange.

2.3.3. ANALYSIS

We can begin examining once the material has been fixed. Analysis aids in the identification of excess materials as well as weak points. Once the errors have been identified, we will proceed to the designing stage, where the part will be modified and evaluate once more.

2.3.4. MANUFACTURING

Once the analysis has determined that the part is safe, the final step is to manufacture it. The right spool flange is CNC machined.

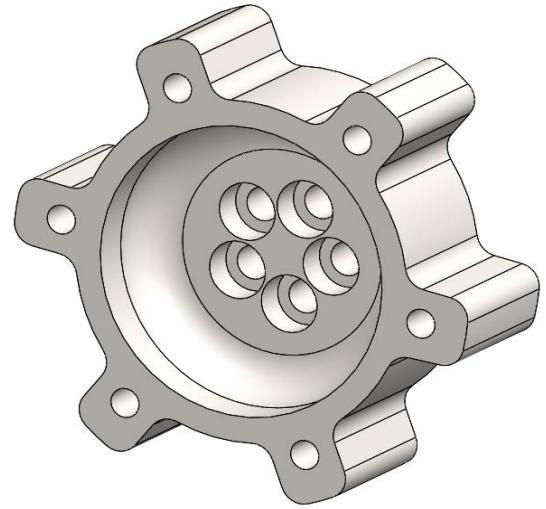

Fig 2.3.1: Front Isometric View of Right Spool Flange

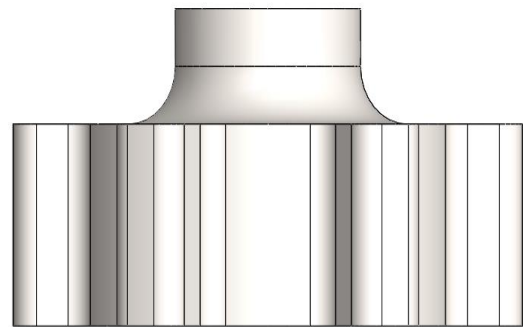

Fig 2.3.2: Front View of Right Spool Flange

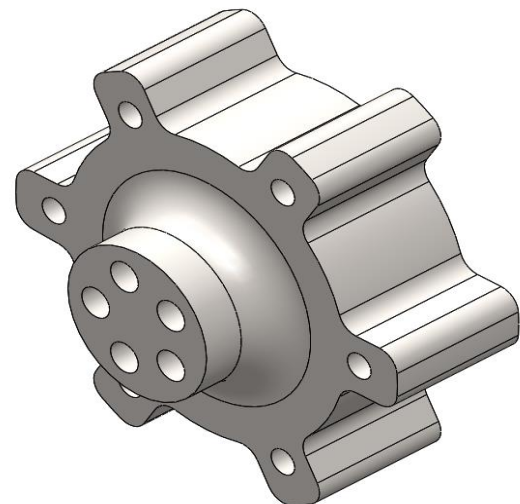

Fig 2.3.3: Rear Isometric View of Right Spool Flange

3. CV AXLE HOUSING

The CV joint housing is mostly employed on four-wheel drives that are designed to allow for the use of a short drive and eliminate center misalignment. It is also used on some rear drive shafts and combination axles. Other

usage include full moon drive applications, and the CV joint is applied to build the internal ring of spline axles in general. In most cases, spline axles are often used to construct the CV joint.

A CV joint housing is a form of wheel housing with a two-link construction. A wheel de-coupler device with a front wheel drive assembly and a constant velocity joint inner housing is also available. The front wheel drive assembly also includes a casing and one or more actuators. The inner housing of a constant velocity joint includes one or more annular apertures that enable fluid to flow between the input and output sides of the housing.

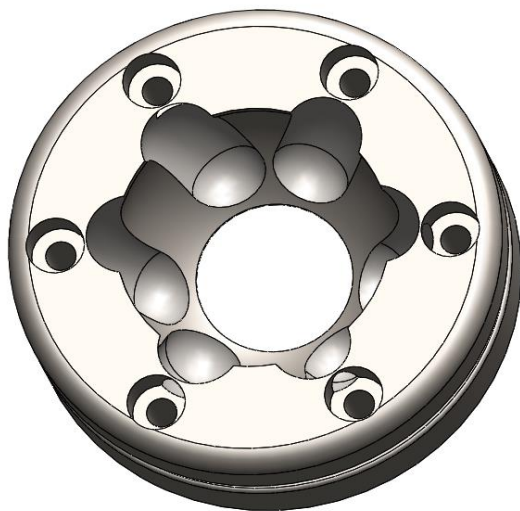

Fig 3.1: Front Isometric View of CV Axle Housing



Fig 3.2: Rear Isometric View of CV Axle Housing

They are most commonly seen in front-wheel drive cars. A Rzeppa joint is made up of a spherical inner shell with 6 grooves and an enclosing outer shell. Each groove directs one ball. The input shaft is centered in a massive, steel, star-shaped "gear" that nests inside a circular cage. Each of the six balls sits in its own groove carved out of the shell at the end of the input shaft. These grooves direct the balls, which are encased in a cage and subsequently by a star-shaped gear. This arrangement is contained inside a cup that is linked to a splined and threaded shaft. Rzeppa joints are utilized in settings where flexible shaft couplings are insufficient for misalignment. They can usually function at angles of up to 48°, and in some cases much higher. The Rzeppa joint was originally created for the automobile sector, and it is still widely used there.

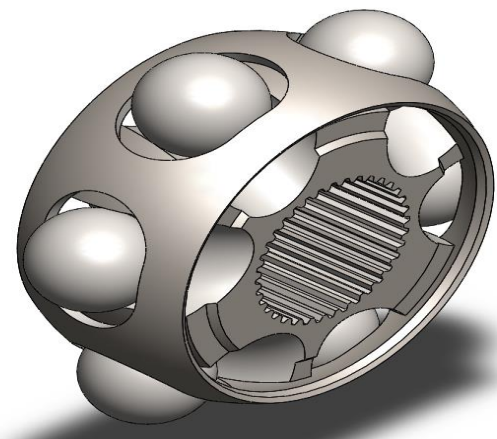

Fig 4.1: Front Isometric View of 6-Ball Joint

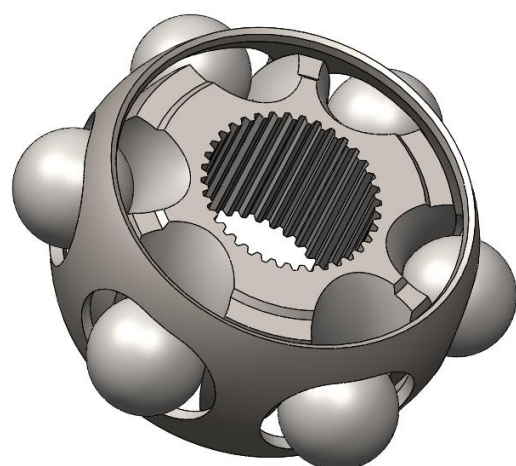

Fig 4.2: Rear Isometric View of 6-Ball Joint

4. RZEPPA JOINT OR C.V JOINT OR 6-BALL JOINT

Constant-velocity joints (also known as homokinetic or CV joints) enable a drive shaft to transmit power across a changing angle while maintaining a constant rotating speed with no discernible increase in friction or play.

5. CV SHAFT

A constant velocity (CV) axle, also known as a half shaft, transmits power from the vehicle's gearbox and differential to the wheels, allowing the vehicle to move forward. The CV joints are required to transfer torque

from the gearbox to the drive wheels at a consistent pace while allowing the suspension's up-and-down motion. CV axles in front-wheel-drive automobiles give torque to the front wheels during turns.

A ball-type CV joint and a tripod-type CV joint are the two most prevalent types of CV joints. Ball-type CV joints are used on the outside side of drive shafts in front-wheel-drive automobiles (outer CV joints), whereas tripod-type CV joints are mainly employed on the inside side (inner CV joints).



Fig 5.1: Isometric View of CV Shaft



Fig 5.2: Front View of CV Shaft

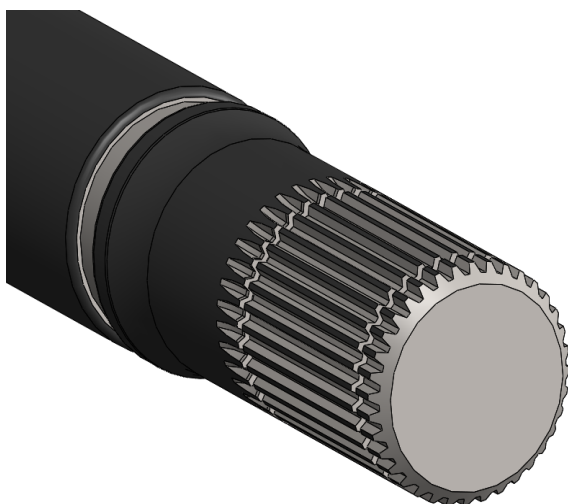

Fig 5.3: Enlarged View of Splined section of shaft

6. TRANSMISSION GEAR (SPROCKET)

KTM Duke 390 RC 390 Racing Rear Sprocket 45 Teeth.

Sprocket Details:

- 45 Tooth.
- Chain Size: #428.

- Centre hole: Approx. 65mm (2.6").
- 6-Hole Sprocket.
- 40mm (side by side) & 80mm (straight across centre hole).
- Every sprocket meets or exceeds the highest possible quality standards.
- All our front and rear sprockets are manufactured to OEM specs using high-grade hardened steel for long life.

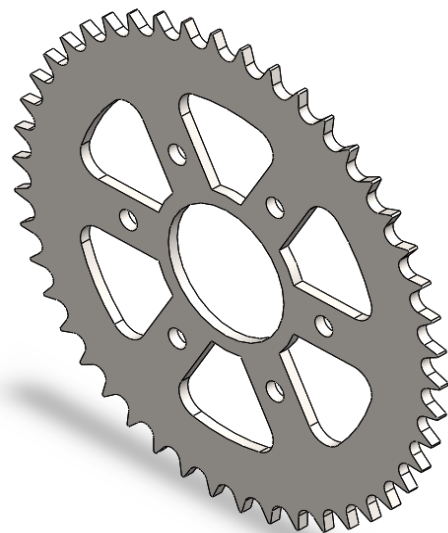

Fig 6.1: Isometric View of Sprocket

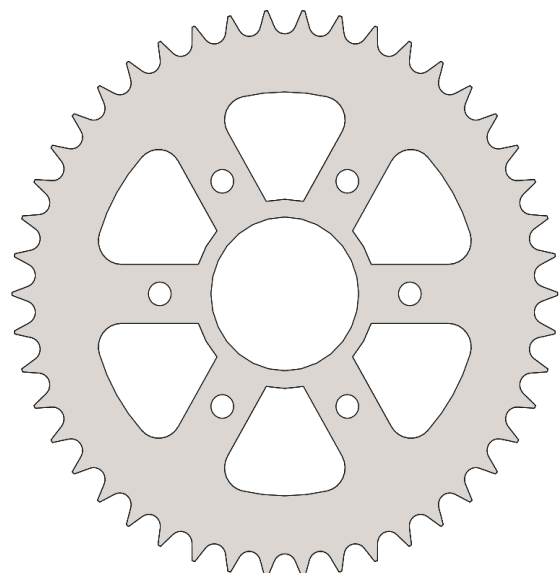

Fig 6.2: Front View of Sprocket

7. BALL-BEARING

Many rotating-motion systems, from vehicle wheels to motors and turbines to medical equipment, rely on rolling-element bearings to function smoothly and efficiently. A ball bearing is a type of rolling-element

bearing that serves three primary functions while enabling motion: it carries weights, reduces friction, and positions moving machine parts.

Ball bearings use balls to separate two "races," or bearing rings, to minimize interfacial interaction or friction among moving surfaces. Rotating balls have a lower coefficient of friction when compared to flat surfaces rubbing against one other. Because there is limited surface contact between the balls and races, ball bearings typically have a lower load capacity for their size than conventional rolling-element bearings.

For this prototype, we're installing tapered Ball bearings. This bearing is used to minimize the friction and heat generated by previous bearing designs, which caused them to fail. Because of the tapered shape, rolled loads are uniformly distributed. This benefits transmission shafts and rotating axles by reducing wear and increasing durability. Because these bearings are so long-lasting, these shafts may run for hundreds of thousands of kilometers without needing to be serviced. Because of their reliability, they can also execute a range of heavy-duty tasks.

Bearing type: TAPER ROLLER BEARING SKF-32008 X
Quantity employed: 02



Fig 7.1: Front Isometric View of SKF-32008 X Bearing

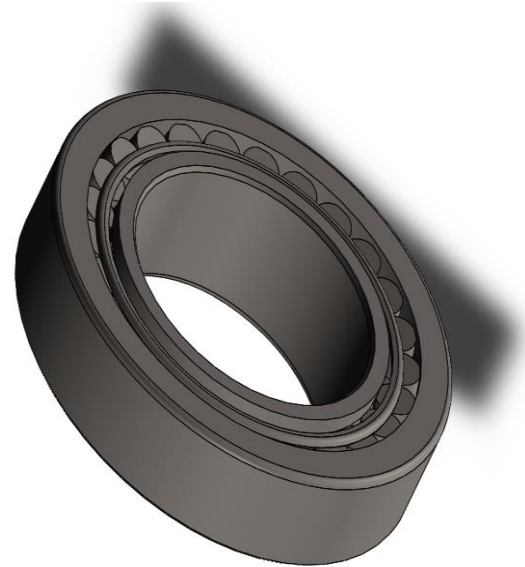

Fig 7.2: Rear Isometric View of SKF-32008 X Bearing

8. BOLT

There are two categories of bolt used in the transmission system. They are Allen Bolts and the Hex Head Bolts (HHB).

Allen Bolts:

A hex key, also referred as either an Allen key or Allen wrench, is a tiny portable tool used to drive bolts and screws that have a hexagonal socket. They come in a variety of sizes, but they all feature the same hexagonal-shaped tip.

There are several advantages to using screws and Allen keys: They are less expensive and easier to make. Their lever arch systems enable for more tightening torque. The key is not at risk of slipping out of the screw.

Series used: IS 2269- M8 x 20- N, IS 2269- M8 x 65- N, and IS 2269- M8 x 35- S.

Hex Head Bolts:

Hex cap screws and hex bolts feature a hexagonal head that is utilized during the tightening of the fastener. A hex cap screw has a washer face under the head and a chamfered end, whereas hex bolts do not have such characteristics and must be tightened with a nut.

Series used: IS 1364 HHB – M8 x 40 x 22- S

8.1. IS 2269- M8 x 20- N:



Fig 8.1.1: Isometric View of M8 x 20- N Allen bolt



Fig 8.1.2: Front View of M8 x 20- N Allen bolt

8.2. IS 2269- M8 x 65- N:

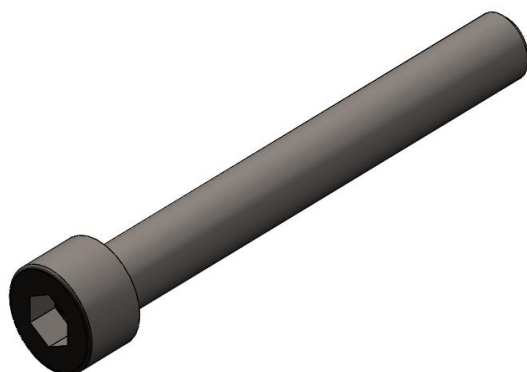

Fig 8.2.1: Isometric View of M8 x 65- N Allen bolt



Fig 8.2.2: Isometric View of M8 x 65- N Allen bolt

8.3. IS 1364 HHB – M8 x 40 x 22- S:

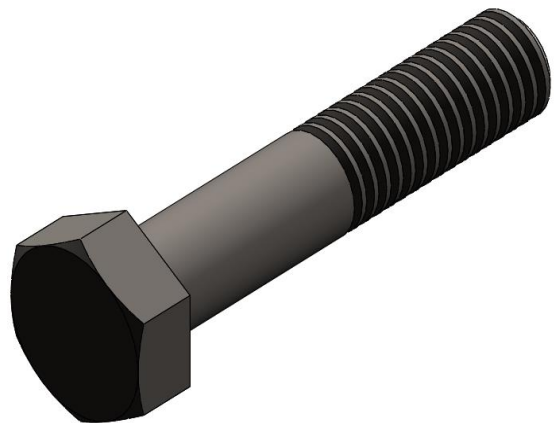

Fig 8.3.1: Isometric View of M8 x 40 x 22- S Hex head bolt

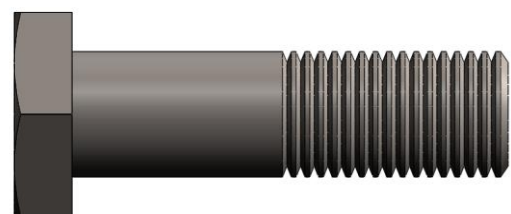

Fig 8.3.2: Front View of M8 x 40 x 22- S Hex head bolt

8.4. IS 2269- M8 x 35- S:



Fig 8.4.1: Isometric View of M8 x 35- S Allen bolt

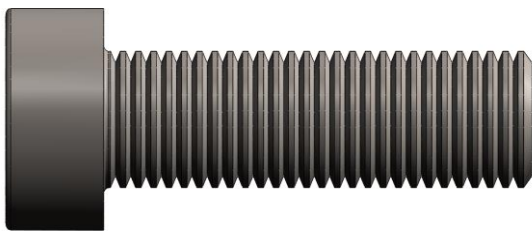

Fig 8.4.2: Front View of M8 x 35- S Allen bolt

9. EXTERNAL RETAINER RING (CIRCLIP)

External retention rings are used to hold shaft casings to the shaft's external surface. These rings are designed to keep the shaft in place.

During tension or compression, the retainer ring secures the bearing in position against with the hub. Because the hub is press-fitted to the rear knuckle, the bearing is kept in place by the hub.

Type: Bowed Preloading Ring

Inner Diameter: 37.7mm

Quantity required: 02 (Each side of *Spool* connector for bearings)



Fig 9: Isometric View of Circlip

10. SUPPORT PLATE

Support plates are essential components of the transmission system because they support the whole spool system. Aside from that, it aids in limiting the movement of bearings. In order to provide consistent weight distribution, two support plates are utilized on either side of the spool connection. The final CAD model of the Support plate was created in SOLIDWORKS and is shown in Figures 10.1 and 10.2. Figures 10.1 and 10.2 show the front and back isometric views of the support plate, respectively. The four guiding concepts in the design process for this product were high strength, low weight, economy, and ease of manufacturing.

10.1. DESIGN

Designing is one of the most essential aspects of the procedure since any errors might endanger the rider. It is important to understand the restrictions associated with those components before creating any sort of drawing. The following elements were taken into account while constructing a good support plate:

1. Chassis mountings:

Each support plate has two holes that allow it to be attached to the chassis body through mountings using a nut and bolt. The slot was designed to promote smoother transmission. A hole is also made on the mid-plane to connect it to the chassis. Figure 10.2 clearly demonstrates this.

2. Bearing Provision:

The bore dimension is determined by the bearing's outer diameter. To prevent undesired motion of the bearing, a 2 mm spacer is provided.

10.2. MATERIAL SELECTION

Material selection is the next essential step in the manufacture of support plates. It will help us achieve our goal of increasing strength while decreasing body weight.

Property	Al7075	EN 24
1. Young's Modulus (GPa)	71.7	210
2. Density (kg/m3)	2810	7840
3. Poisson's ratio	0.33	0.294
4. Tensile Strength (MPa)	572	900

Based on the above parameters, EN 24 is selected.

10.3. ANALYSIS

After the material has been corrected, we may continue the analysis. Evaluation assists in the identification of excess materials as well as weak places. Once the problems have been discovered, we will go on to the conceptual design stage, where the portion will be modified and examined again.

10.4. MANUFACTURING

Once the analysis has determined that the item is safe, the final step is to produce it. Both support plates are CNC machined.

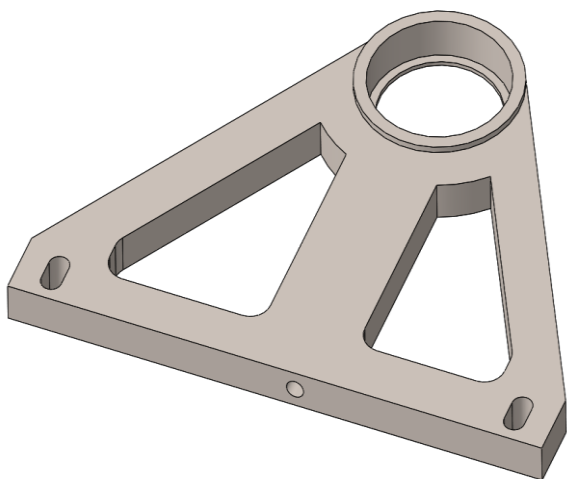

Fig 10.1: Front Isometric View of Support Plate

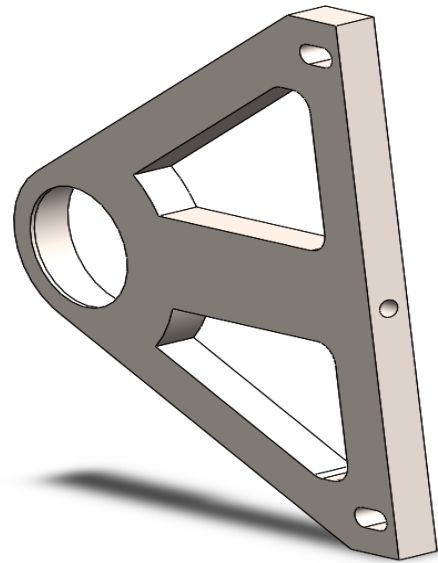

Fig 10.2: Rear Isometric View of Support Plate

11. ENGINE

Engine plays an important role for transmission of any vehicle. This is due to the simple fact that Engine acts as the power source for transmission. Fig 11.1 represents the Engine used in the ATV. Engine used: Pulsar 220 - (2013 Model).

It has, at its heart, an air-cooled, four-stroke, 219cc, single cylinder engine paired to a five-speed manual transmission, and can produce a claimed 21 horsepower and 19 Nm of torque.

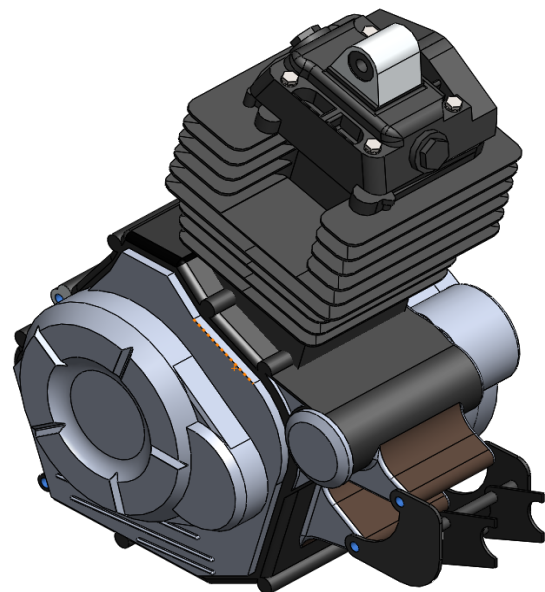

Fig 11.1: Isometric View of Engine

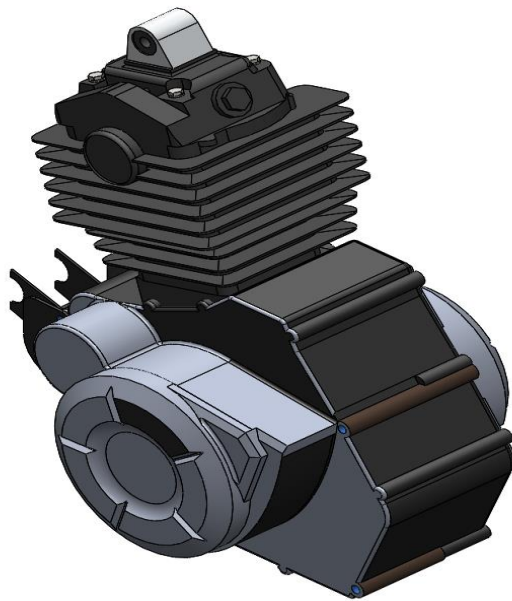

Fig 11.2: Rear Isometric View of Engine

Following are the specifications of the Engine:

Engine	4 Stroke, Oil cooled
Bore x Stroke	67.00mm x 62.4mm
Eng. Displacement	220 cc
Compression Ratio	9.5 +/- 0.5 : 1
Idling Speed	1400 + 100
Max. Net Power	20.93 PS at 8500 RPM
Max. Net Torque	18.55 Nm at 7000 RPM
Ignition System	DC CDI
Spark Plug (2 Nos.)	Champion RG6HCC
Spark Plug Gap	0.7 to 0.8 mm
Lubrication	Wet sump, Forced
Transmission	5 speed constant mesh

Table 1: Engine Specifications

12. COMPLETE ASSEMBLY

Starting with the Left Spool Flange, which is attached to the CV housing via Allen bolts on one side. The sprocket is connected to the sprocket lobe in the left spool flange

on the other side of the connector. Through chains, the sprocket is connected to the engine, generating a chain-drive and sending power to the power-train assembly to rotate. Moving on to the spool connector, which will be attached on one side to the left spool flange and on the other side to the right spool flange. Bearings are present on both sides of the spool connection, but their movement is constrained on both sides by the circlip and the spool body. Two support plates are provided on the spool connector to offer support to the powertrain system. It also serves to encapsulate the bearings. These support plates are attached to the chassis via mountings using a nut and bolt. The right spool flange is next, which is connected to the CV housing at one end and the Spool connector at the other. Figures 12.1 and 12.2 show the front and back isometric views of the Spool-drive transmission assembly. Figure 12.3 illustrates an isometric view of a fully built transmission system with the ATV. Figure 12.4 exhibits the back perspective of an ATV when turning with the transmission assembly. Figure 12.5 portrays a rear view of an ATV while bumping with the transmission system.

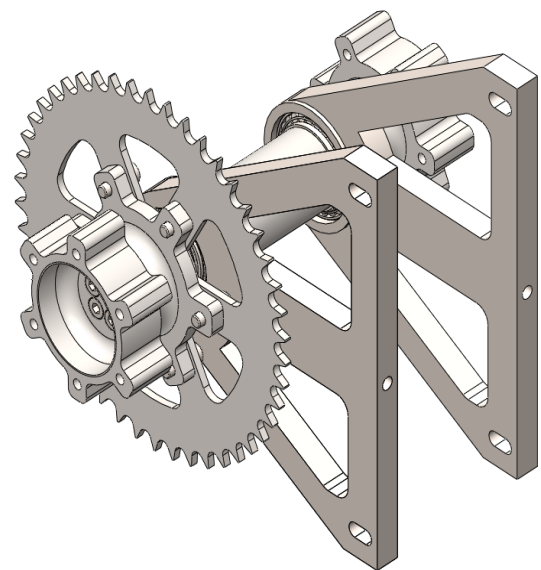

Fig 12.1: Front Isometric View of Spool-Drive Transmission Assembly

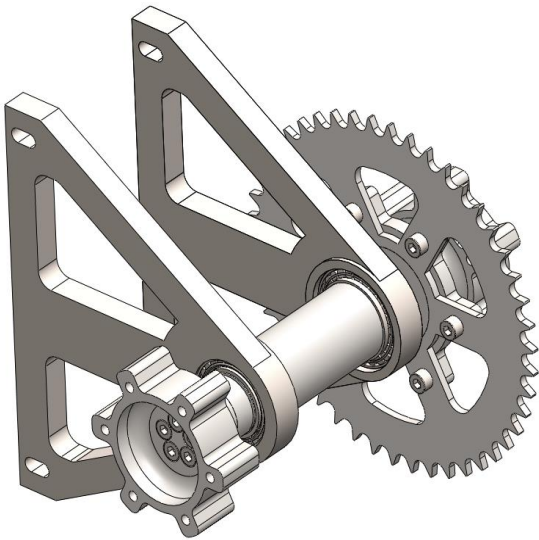

Fig 12.2: Rear Isometric View of Spool-Drive Transmission Assembly



Fig 12.4: Rear View of Complete Transmission Assembly while turning

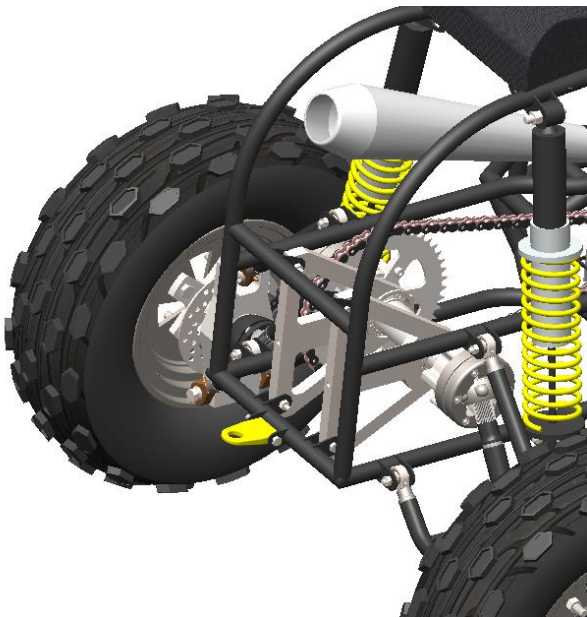

Fig 12.3: Isometric View of Complete Transmission Assembly

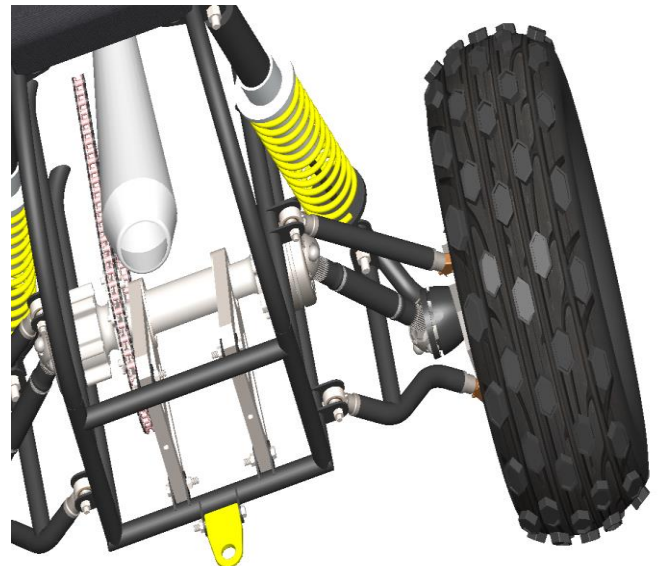

Fig 12.5: Rear View of Complete Transmission Assembly while bumping

13. ANALYSIS REPORT

13.1. STRESS ANALYSIS

- Left Spool Flange

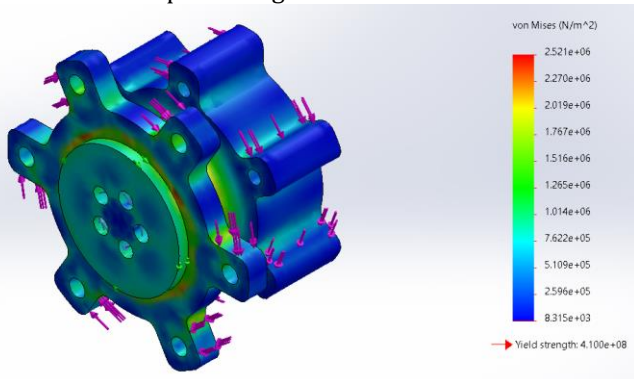

Fig 12.1.1: Stress Analysis of Left Spool Flange

- Spool Connector

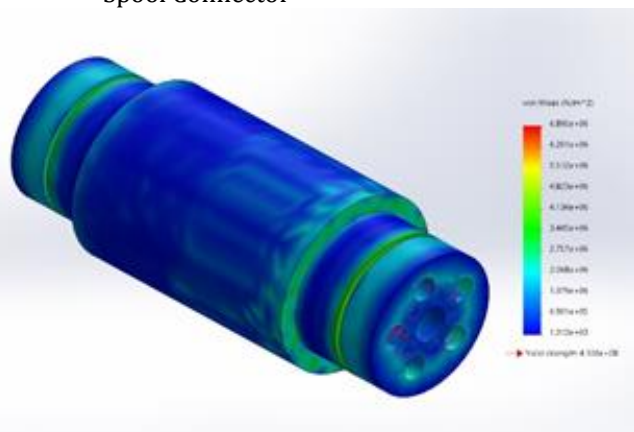

Fig 12.1.2: Stress Analysis of Spool Connector

- Right Spool Flange

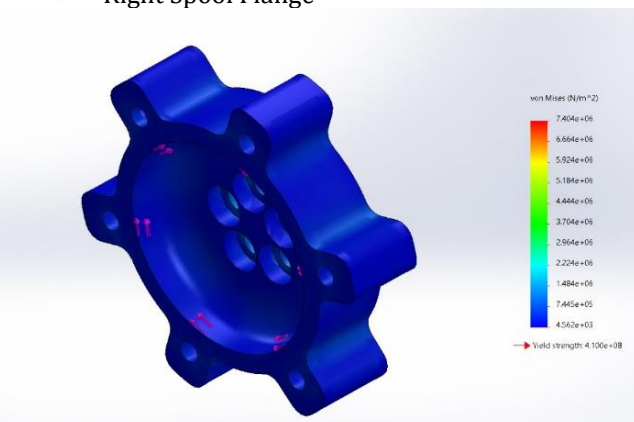

Fig 12.1.3: Stress Analysis of Right Spool Flange

- Spool-Drive Transmission Assembly

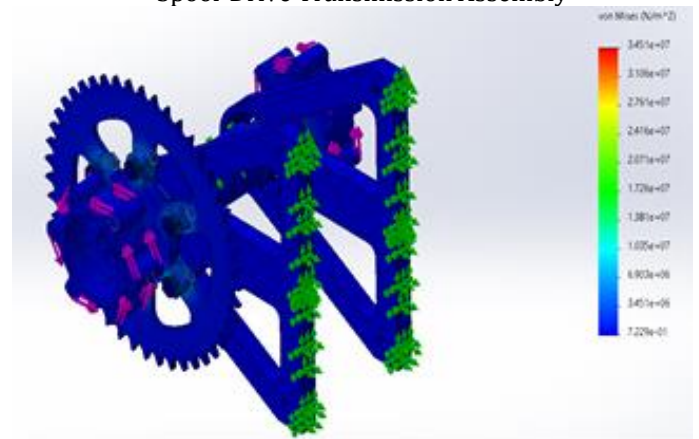

Fig 12.1.4: Stress Analysis of Spool-Drive Transmission Assembly

- IS 2269- M8 x 20- N

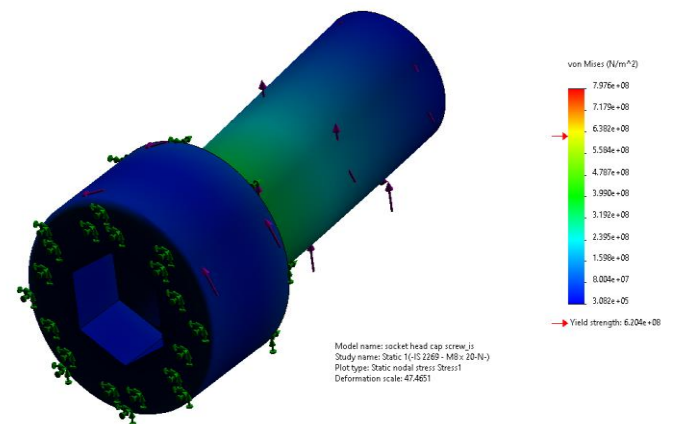

Fig 12.1.5: Stress Analysis of M8 x 20- N Allen bolt

- IS 2269- M8 x 65- N

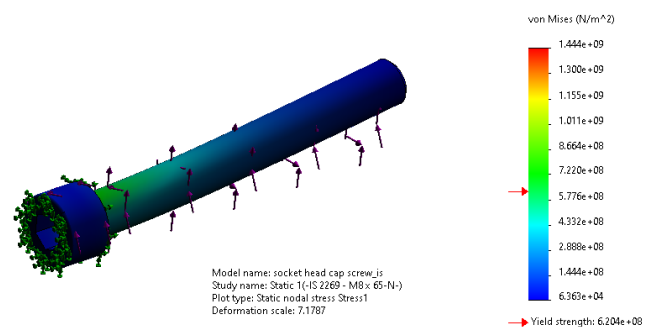

Fig 12.1.6: Stress Analysis of M8 x 65- N Allen bolt

- IS 1364 HHB – M8 x 40 x 22- S

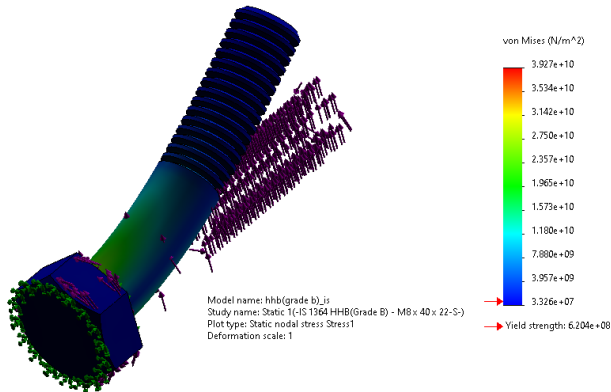

Fig 12.1.7: Stress Analysis of M8 x 40 x 22- S Hex head bolt

- Spool Connector

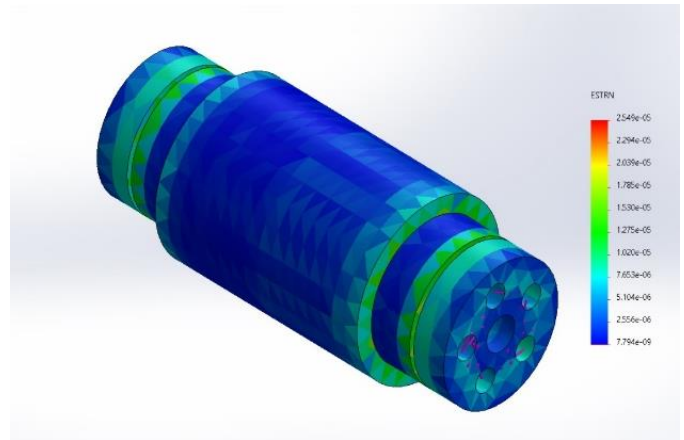

Fig 12.2.2: Strain Analysis of Spool Connector

- IS 2269- M8 x 35- S

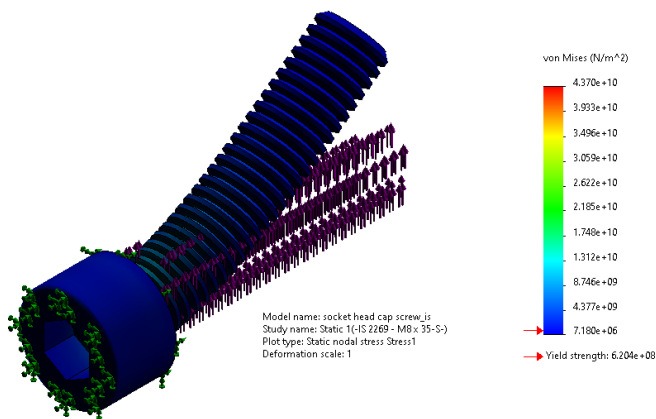

Fig 12.1.8: Stress Analysis of M8 x 35- S Allen bolt

- Right Spool Flange

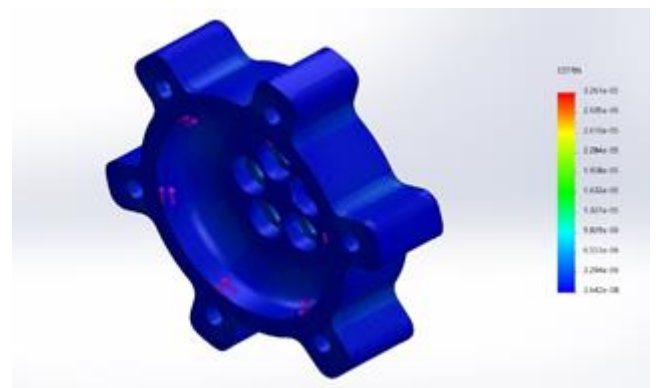

Fig 12.2.3: Strain Analysis of Right Spool Flange

13.2. STRAIN ANALYSIS

- Left Spool Flange

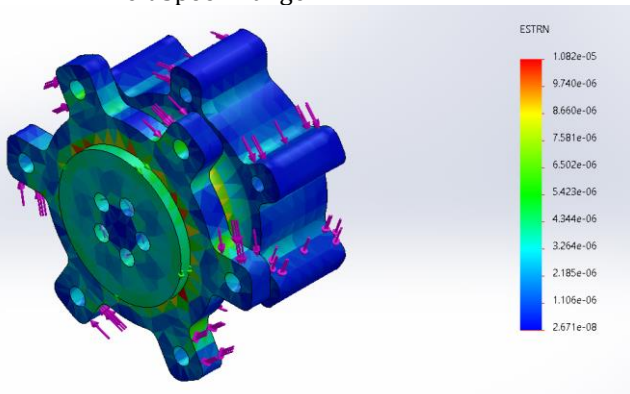

Fig 12.2.1: Strain Analysis of Left Spool Flange

- Spool-Drive Transmission Assembly

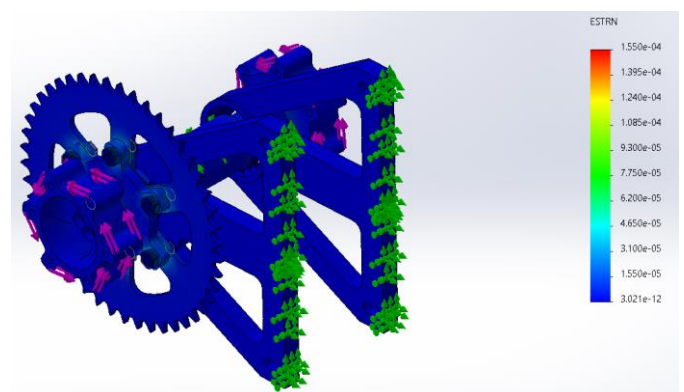

Fig 12.2.4: Strain Analysis of Spool-Drive Transmission Assembly

- IS 2269- M8 x 20- N

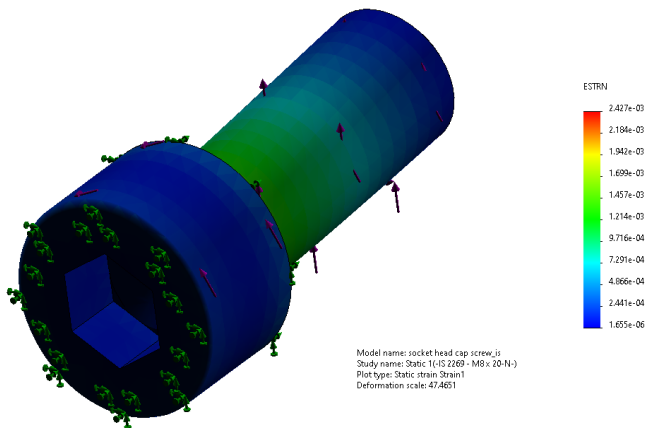

Fig 12.2.5: Strain Analysis of M8 x 20- N Allen bolt

- IS 2269- M8 x 35- S

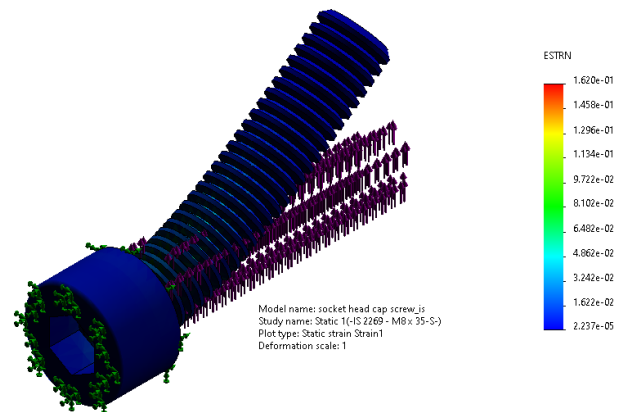

Fig 12.2.8: Strain Analysis of M8 x 35- S Allen bolt

- IS 2269- M8 x 65- N

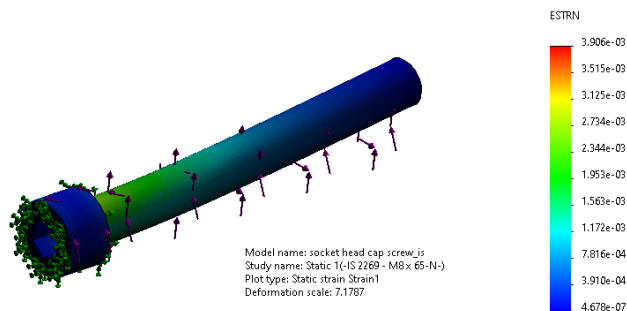

Fig 12.2.6: Strain Analysis of M8 x 65- N Allen bolt

- IS 1364 HHB – M8 x 40 x 22- S

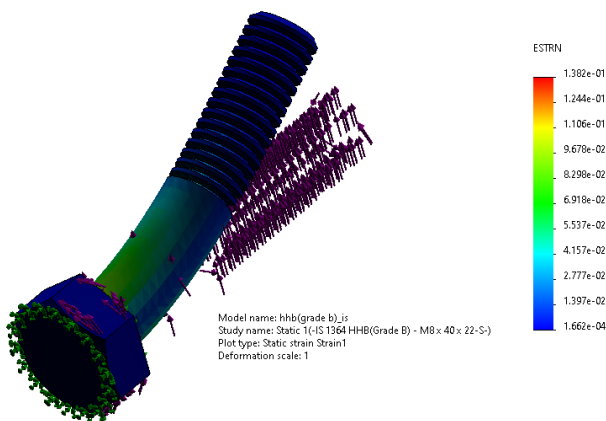

Fig 12.2.7: Strain Analysis of M8 x 40 x 22- S Hex head bolt

13.3. DISPLACEMENT ANALYSIS

- Left Spool Flange

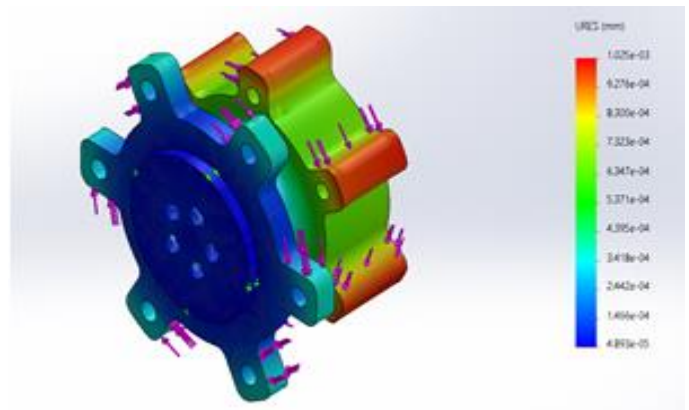

Fig 12.3.1: Displacement Analysis of Left Spool Flange

- Spool Connector

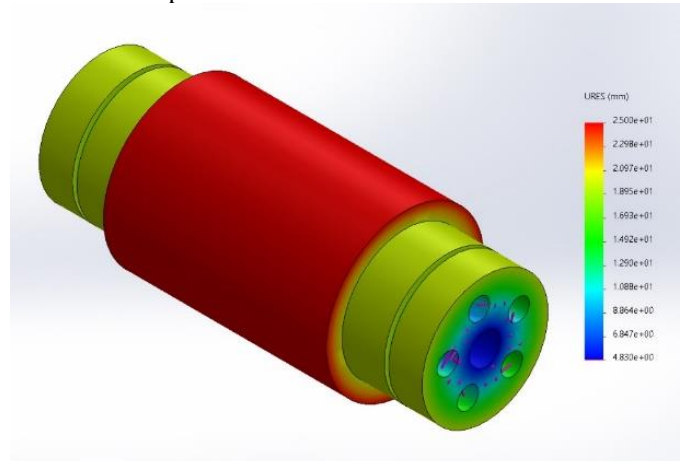

Fig 12.3.2: Displacement Analysis of Spool Connector

- Right Spool Flange

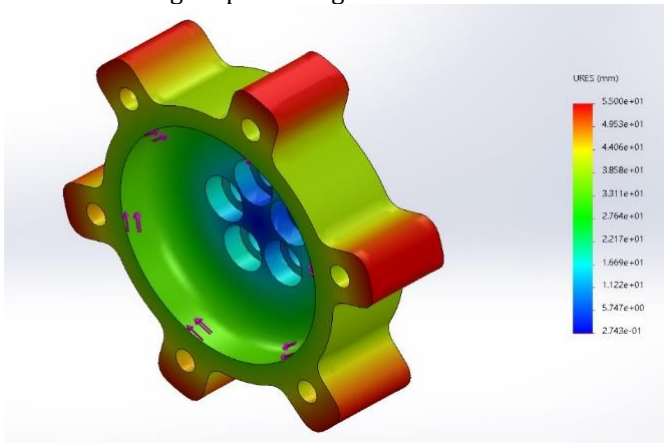

Fig 12.3.3: Displacement Analysis of Right Spool Flange

- Spool-Drive Transmission Assembly

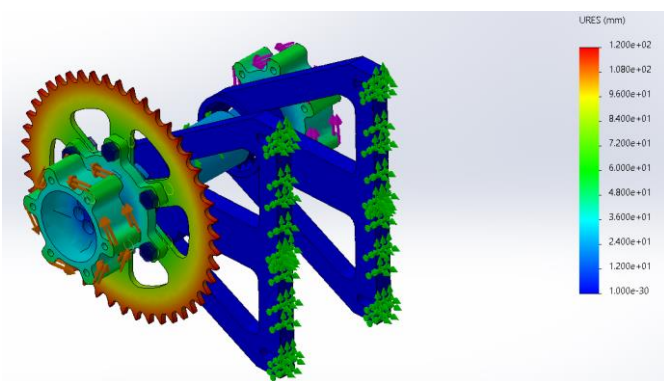

Fig 12.3.4: Displacement Analysis of Spool-Drive Transmission Assembly

- IS 2269- M8 x 20- N

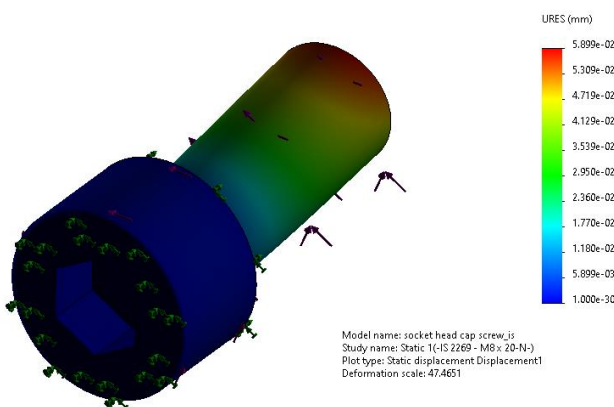

Fig 12.3.5: Displacement Analysis of M8 x 20- N Allen bolt

- IS 2269- M8 x 65- N

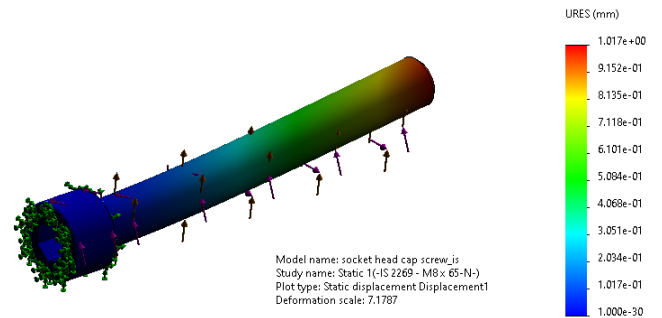

Fig 12.3.6: Displacement Analysis of M8 x 65- N Allen bolt

- IS 1364 HHB – M8 x 40 x 22- S

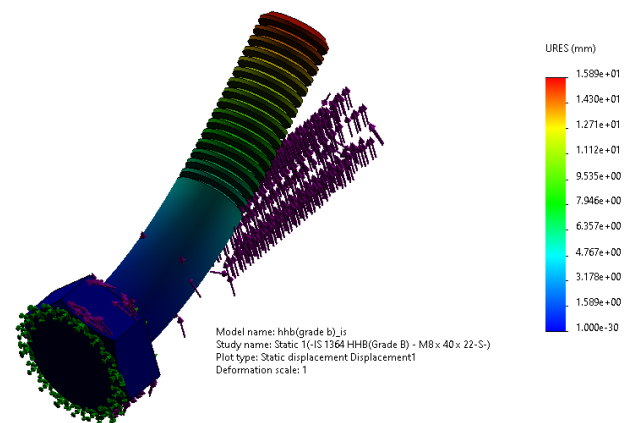

Fig 12.3.7: Displacement Analysis of M8 x 40 x 22- S Hex head bolt

- IS 2269- M8 x 35- S

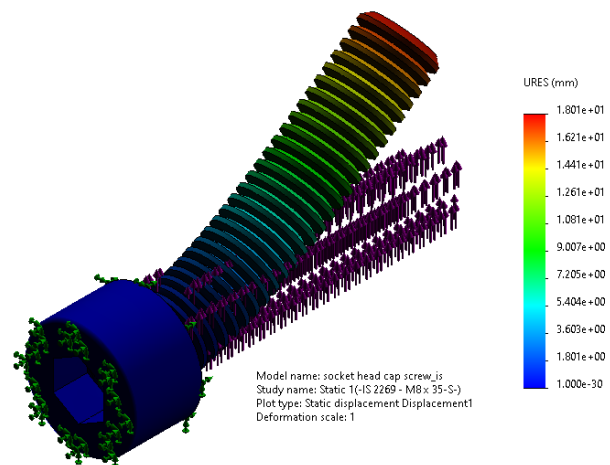

Fig 12.3.8: Displacement Analysis of M8 x 35- S Allen bolt

14. RESULT

- Here $1e-X = 10^{-X}$ and $1e+X = 10^{+X}$.

PARTS	STRESS (N/m ²)		RESULT
	MIN	MAX	
LEFT SPOOL FLANGE	8.31e+3	2.52e+6	Safe.
SPOOL CONNECTOR	1.31e+3	6.89e+6	Safe.
RIGHT SPOOL FLANGE	4.57e+3	7.4e+6	Safe.
M8 x 20- N ALLEN BOLT	3.08e+5	7.98e+8	Safe.
M8 x 65- N ALLEN BOLT	6.36e+4	1.44e+9	Safe.
M8 x 40 x 22- S HEX HEAD BOLT	3.33e+7	3.93e+10	Safe.
M8 x 35- S ALLEN BOLT	7.18e+6	4.37e+10	Safe.

PARTS	STRAIN	
	MIN	MAX
LEFT SPOOL FLANGE	2.67e-8	1.08e-5
SPOOL CONNECTOR	7.8e-9	2.55e-5
RIGHT SPOOL FLANGE	3.64e-8	3.26e-5
M8 x 20- N ALLEN BOLT	1.65e-6	2.43e-3
M8 x 65- N ALLEN BOLT	4.68e-7	3.91e-3
M8 x 40 x 22- S HEX HEAD BOLT	1.66e-4	1.38e-1
M8 x 35- S ALLEN BOLT	2.24e-5	1.62e-1

15. CONCLUSIONS

The following points are summed up in this paper:

- Through experimentation it is observed that Spool drive transmission is way more efficient than Differential system.
- It is important to note that all the CAD models were build using SOLIDWORKS software.
- Analysis is carried out using SOLIDWORKS Simulation software.
- The ATV is safe as the complete transmission assembly is safe as seen in the analysis.

- Due to optimization in design; further cost reduction, material reduction, and efficiency improvement was achieved.
- We were able to minimize the total cost, weight, and increase the strength by using EN 8 for Support plates and EN 24 for the Spool-drive components instead of AL 7075.
- Having interchangeable Support plate improves reusability and reduces the overall cost.

16. REFERENCES

- FMAE's QBDC Season 2020 Rulebook.
- Rodrigo De Oliveria Santos-The Absolute Guide to Racing Tires – Part1.
- MUR blog- Differential. What's the difference?
- William F. Milliken and Douglas L. Milliken –'Race Car Vehicle Dynamics' fifth printing.
- Prof. Dr. G.P. Deshmukh, Prof. Pornima T. Godbole, Omkar R. Totre, Ronak R. Sarkar, Ashish A. Jadhav, and Ganesh P. Avahad- "Design, Optimization and ANSYS analysis of component of ATV wheel assembly", International Research Journal of Engineering and Technology, IRJET V815228 e-ISSN: 2395-0056 p-ISSN: 2395-0072 Volume: 08 Issue: 05 | May 2021.
- Madhura Y. Sawatkar, Nitinchand G. Yadav, Asitkumar A. More, and Ajit N. Tupe- "DESIGN AND ANALYSIS OF ATV WHEEL ASSEMBLY", International Research Journal of Engineering and Technology, IRJET V815367 e-ISSN: 2395-0056 p-ISSN: 2395-0072 Volume: 08 Issue: 05 | May 2021.
- Aman B. Sharma, Ronak R. Sarkar, Omkar R. Totre, Gauravkumar V. Singh, Ashish A. Jadhav, Latika M. Rahate- "REAR WHEEL ASSEMBLY IN A QUAD-BIKE: DESIGN AND ANALYSIS", International Research Journal of Engineering and Technology, IRJET V81952 e-ISSN: 2395-0056 p-ISSN: 2395-0072 Volume: 08 Issue: 09 | Sep 2021.
- Dr. V.K. Saini, Sunil Kumar, Abhishek Singh, Abhishek Srivastava, Amit Sharma, Prashant Dobriyal- "DESIGN AND DEVELOPMENT OF A TRANSMISSION SYSTEM FOR AN ALL TERRAIN VEHICLE", International Research Journal of Engineering and Technology, IRJET V41589 e-ISSN: 2395 -0056 p-ISSN: 2395-0072 Volume: 04 Issue: 05 | May -2017.