

FINITE ELEMENT ANALYSIS (FEA) OF BAJA ALL-TERRAIN VEHICLE (ATV)

Amogh Kothawade¹, Mirza Kazim Bakher²

^{1,2}Department of Mechanical Engineering, Vidyavardhaka College of Engineering -570002, Karnataka, India

ABSTRACT : This report is a summary of the analysis work conducted by team VVCE Baja. It consists of the structural analysis of the All-Terrain Vehicle including the roll cage and all the other system components associated with it. The 3-D solid model of the roll cage and components were generated using SolidWorks 2016 and Catia V5 and the analysis was conducted on ANSYS Workbench 19. The main objective of the analysis is to design a vehicle that is highly competent without compromising on the safety aspects.

INTRODUCTION

The roll cage of an All-Terrain vehicle is a skeletal structure that not only protects the driver in case of a collision but also supports the various systems such as suspension, steering, braking and powertrain. The design of a roll cage is a crucial aspect on which the success of the ATV is dependant. If the roll cage fails at any instance, it will put the driver at tremendous risk. Therefore, during the design of a roll cage, factors such as safety, manufacturing ease, compactness, durability, ergonomics and weight are considered.

DESIGN CONSIDERATIONS

The main focus of design was to construct a vehicle that was light in weight, easy to manufacture, costed less while giving utmost important to the safety of the driver.

The design considerations that were considered were material selection, cross section selection, frame design and finite element analysis.

1. MATERIAL SELECTION

One of the major factors that decided the weight and strength of a vehicle is material selection. As per the SAE Baja rulebook 2021, all members used in the vehicle must be made out of tubular steel with at least 0.18% of carbon content. The primary must have an outer diameter of 1" (25.4 mm) with a minimum wall thickness of 3mm and the secondary members must have an outer diameter of 1" (25.4mm) and minimum wall thickness of 0.89mm. Keeping all these factors in mind, we conducted thorough research on all the materials that were available to us and compared them based on the following criteria

MATERIAL	AISI 1018	AISI 1020	AISI 4130
YIELD STRENGTH	370 MPa	294 MPa	460 MPa
TENSILE STRENGTH	440 MPa	394 MPa	560 MPa
ELONGATION	15%	36.5%	21.50%
COMPOSITION	C, Fe, Mn, P, S	C, Fe, Mn, P, S	C, Fe, Mn, P, S, Si, Mo

Table 1. Materials and their properties

From the comparison, we deduced that **AISI 4130 was the best material option.**

AISI 4130 is a low-alloy steel containing chromium and molybdenum as strengthening agents. The steel has good strength, toughness, weldability and machinability. It is also corrosion resistant and has high strength to weight ratio.

2. CROSS SECTION

After the material was selected, the cross section of the members was decided as follows-

- Primary members – 1" outer diameter with 3mm wall thickness
- Secondary members – 1" outer diameter with 1mm wall thickness

3. ERGONOMICS

One of the major design considerations while designing the roll cage was driver ergonomics. Ergonomics is a study of the layout and design of driver control components such as steering wheel placement, foot pedal placement, seat placement and so on.

As per the SAE Baja Rulebook 2021, The vehicle must be capable of carrying one person 190 cm (75 in.) tall weighing 113 kgs. Some of the major factors that were taken into account were the inclination of the firewall, location of seat and inclination, location of steering wheel and the overall dimensions of the footbox in order to

allow easy movement of the driver's feet at all times without any obstructions. Care was taken to ensure all the lateral clearances; steering wheel clearances and head clearances were met.

4. SAFETY

Safety is one the most important factors when it comes to the designing of a vehicle. The roll cage was designed to ensure that the driver will be safe during the event of a collision. All the scenarios of impact were analysed and design was altered at multiple stages to obtain high values of Factor of Safety (FOS) to ensure maximum safety of the driver.

ROLL CAGE DESIGN

After all the above-mentioned design considerations were taken into account, the roll cage was designed. Strength, safety and weight were the major criteria for the final design of the roll cage.

The roll cage was designed to keep the centre of gravity of the vehicle as low as possible to minimize roll. The weight was kept to a minimum in order to ensure the vehicle will be competent in terms of acceleration. All the clearances as per the rulebook were met and safety was a very high priority.

VIEWS OF ROLL CAGE AND ATV

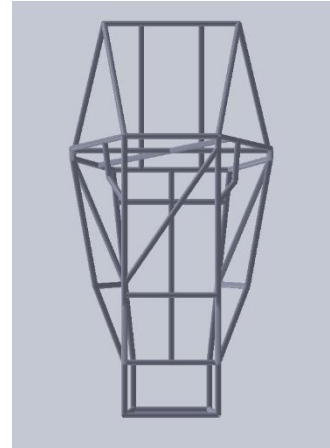
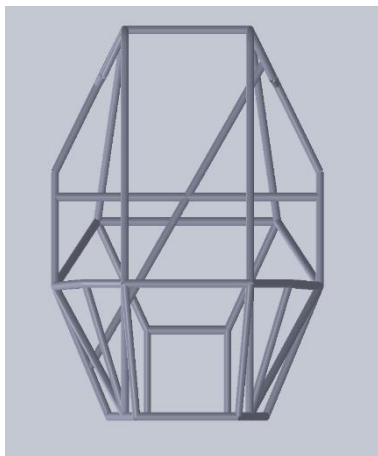

Figure1. Front and top view of roll cage

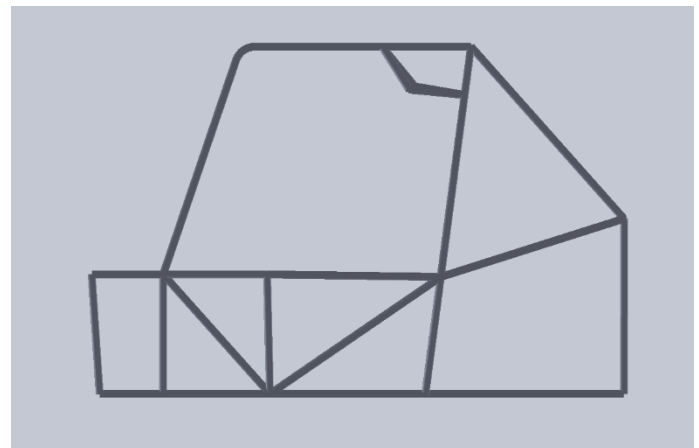

Figure2. Side view of roll cage

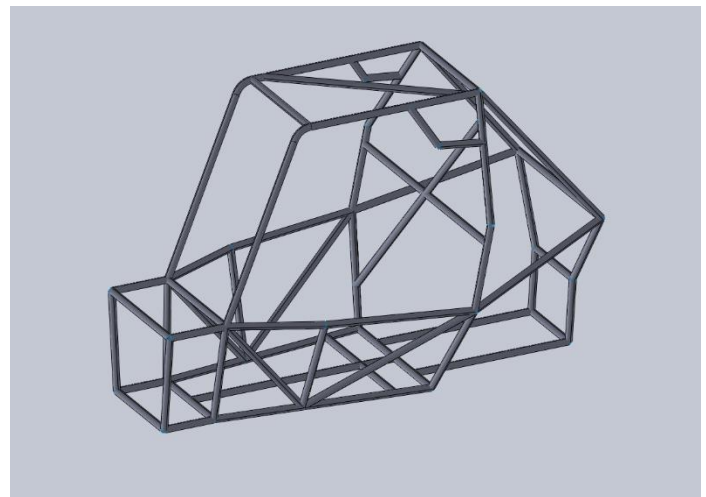

Figure3. Isometric view of roll cage

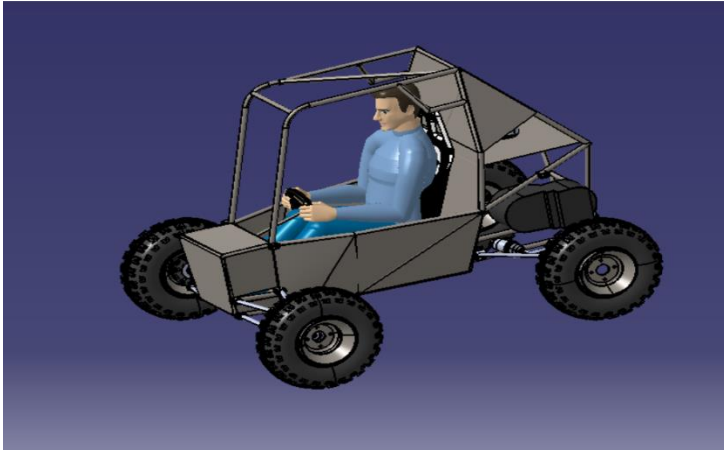

Figure4. Isometric view of ATV with driver

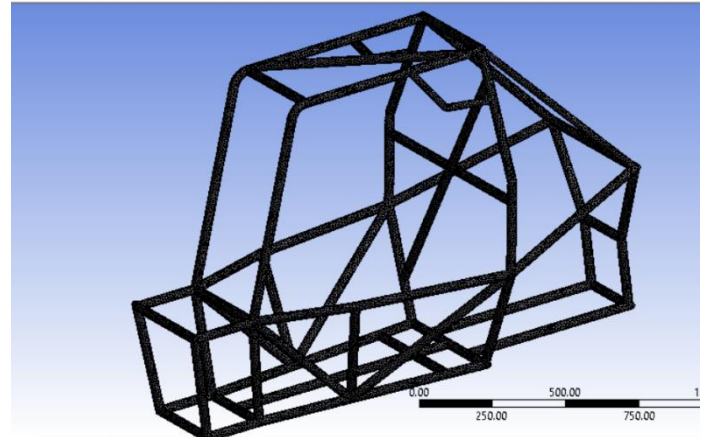

Figure6. Roll cage meshing

FINITE ELEMENT ANALYSIS

The 3-D model of the roll cage was modelled using SolidWorks 2016 and the analysis was conducted using ANSYS Workbench 19.

1. MESH SIZE SELECTION

For the purpose of obtaining a mesh size that does not affect deformation values drastically while reducing computing time, a mesh size of 5mm was selected. At this value of mesh size, deformation becomes constant and there will be negligible changes in the accuracy of the results in the accuracy of the results on further reduction in mesh size.

2. TYPE OF ELEMENT

We are selecting 2-D element as the element type as the length (x) and outer diameter (y) of pipe is far greater than the thickness (t) of the pipe (x, y >> t)

Therefore, a mesh primary consisting of Tetrahedron (tet) elements was used for the purpose of analysis.

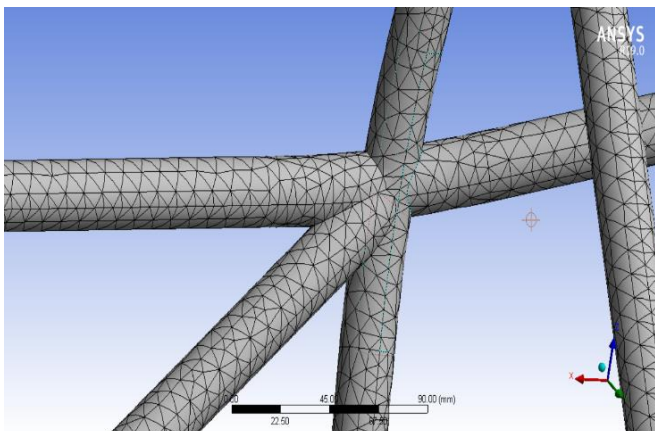

Figure5. Zoomed roll cage meshing (5mm)

STATIC ANALYSIS

1. FRONT IMPACT

This analysis is done to simulate a scenario where the vehicle hits a tree or another vehicle from the front. Under such conditions, the forces act on the front most members of the chassis.

Input parameters:

- We consider the total mass of the vehicle including the driver to be 250kg
- The vehicle is assumed to be travelling at a maximum speed of 55Km/h or 15.27m/s
- The impact time for front impact was considered as 0.15 seconds

Boundary conditions:

- The suspension points are fixed
- The force is applied on the forward most members of the chassis i.e. nose members

Calculations:

Mass of vehicle (m) = 250kg

Velocity of vehicle (v) = 55km/h or 15.27m/s

Impact time (t) = 0.15s

We know that Force (F) = Mass x Acceleration and acceleration (a) = velocity/time

$$i.e. F = m \times \frac{v}{t}$$

$$F = 250 \times \frac{15.27}{0.15}$$

$$F = 25,450\text{N or } 25\text{KN}$$

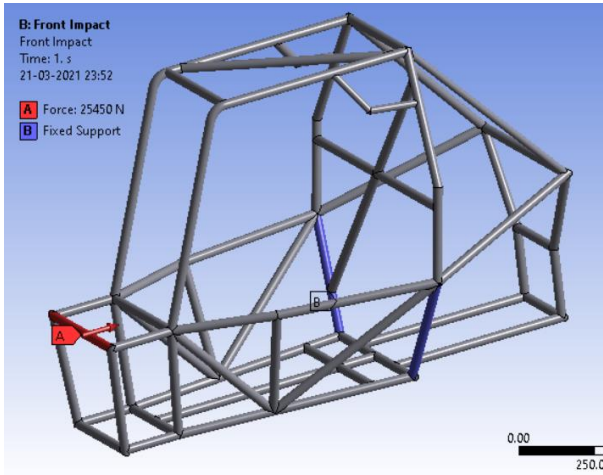

Figure7. Front Impact Boundary Conditions

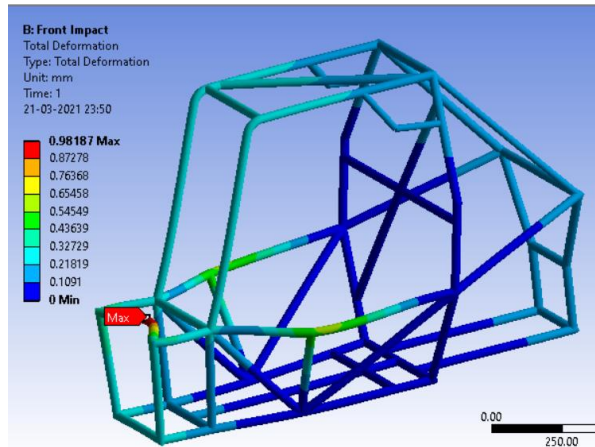

Figure7. Front Impact Deformation

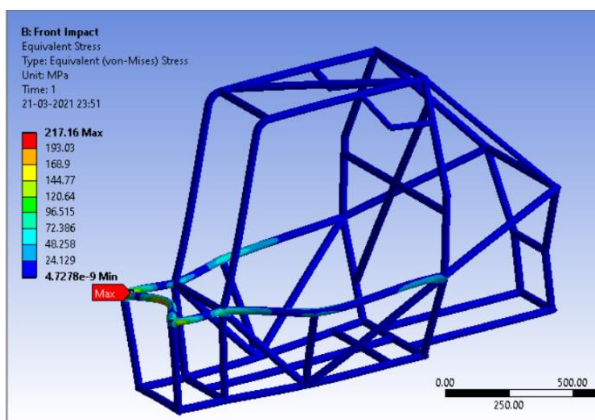

Figure8. Front Impact Equivalent Stress

RESULT: The equivalent stress induced is 217.6 MPa. Hence, FOS is found to be 2.118 with maximum deformation of 0.98 mm which is within permissible limit.

2. Rear Impact

This analysis is done to simulate a scenario where the vehicle is hit by another vehicle from behind. Under such conditions, the forces act on the rear most members of the chassis.

Input parameters:

- We consider the total mass of the vehicle including the driver to be 250kg
- The vehicle is assumed to be travelling at a maximum speed of 55Km/h or 15.27m/s
- The impact time for rear impact was considered as 0.3 seconds as bodies are deformable

Boundary conditions:

- The suspension points are fixed
- The force is applied on the rear most members of the chassis

Calculations:

$$\text{Mass of vehicle (m)} = 280\text{kg}$$

$$\text{Velocity of vehicle (v)} = 55\text{km/h or } 15.27\text{m/s}$$

$$\text{Impact time (t)} = 0.3\text{s}$$

We know that Force (F) = Mass x Acceleration and acceleration (a) = velocity/time

$$\text{i.e. } F = m \times \frac{v}{t}$$

$$F = 250 \times \frac{15.27}{0.3}$$

$$F = 12725 \text{ or nearly } 13\text{KN}$$

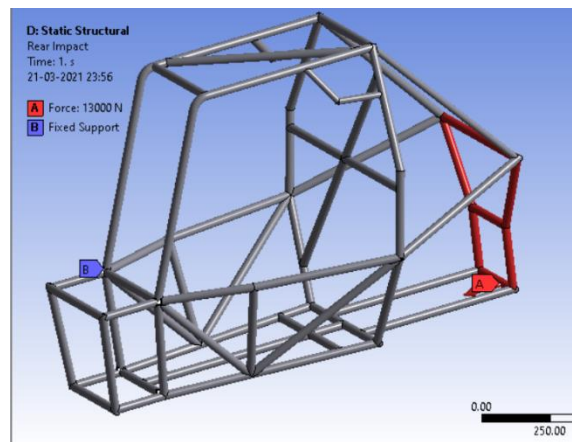

Figure9. Rear Impact Boundary Conditions

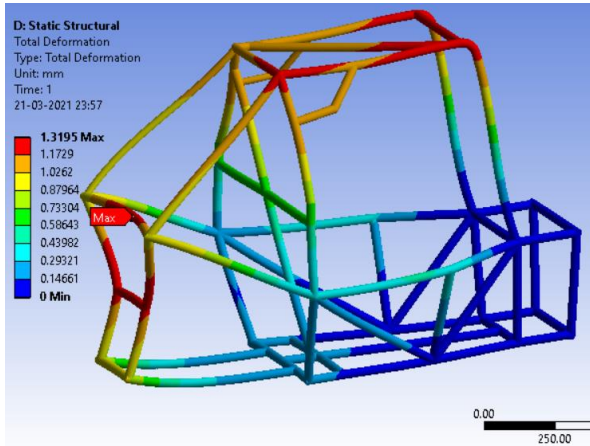

Figure10. Rear Impact Deformation

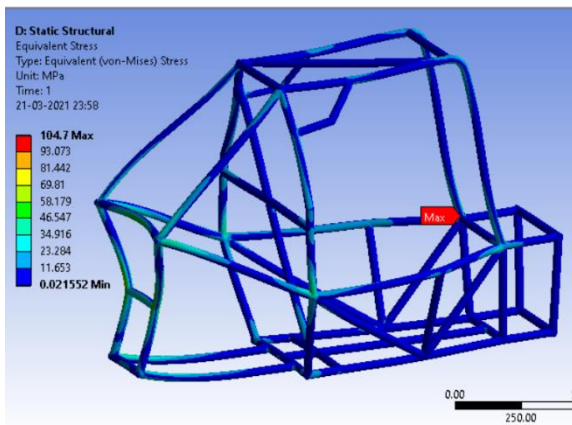

Figure11. Rear Impact Stress

RESULT: The equivalent stress induced is 104.7 MPa. Hence, FOS is found to be 4.3 with maximum deformation of 1.39 mm which is within permissible limit.

3. Side Impact

This analysis is done to simulate a scenario where the vehicle is hit by another vehicle at the side. Under such conditions, the forces act on the side members of the chassis.

Input parameters:

- We consider the total mass of the vehicle including the driver to be 250kg
- The vehicle is assumed to be travelling at a maximum speed of 55Km/h or 15.27m/s
- The impact time for front impact was considered as 0.3 seconds as bodies are deformable

Boundary conditions:

- The suspension points are fixed
- The force is applied on the side most members of the chassis

Calculations:

Mass of vehicle (m) = 250kg

Velocity of vehicle (v) = 55km/h or 15.27m/s

Impact time (t) = 0.3s

We know that Force (F) = Mass x Acceleration and acceleration (a) = velocity/time

$$\text{i.e. } F = m \times \frac{v}{t}$$

$$F = 250 \times \frac{15.27}{0.3}$$

$$F = 12,750\text{N or nearly } 13\text{KN}$$

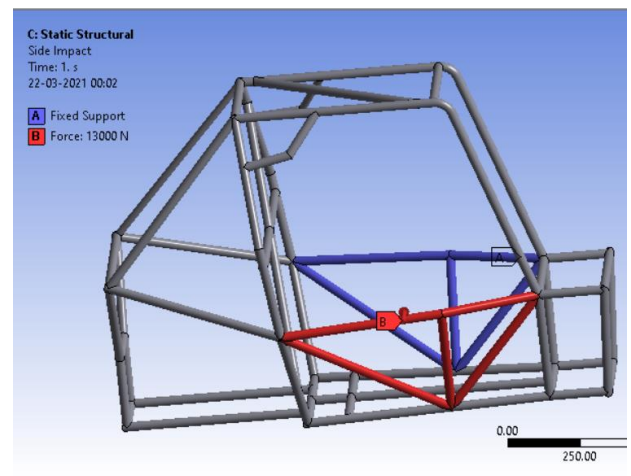

Figure12. Side Impact Boundary Conditions

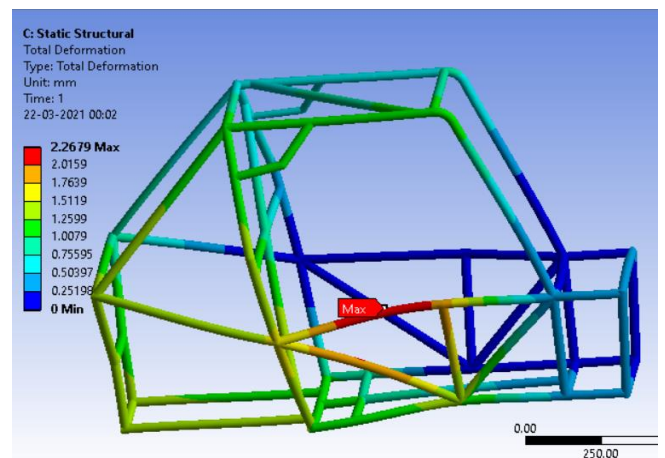

Figure13. Side Impact Deformation

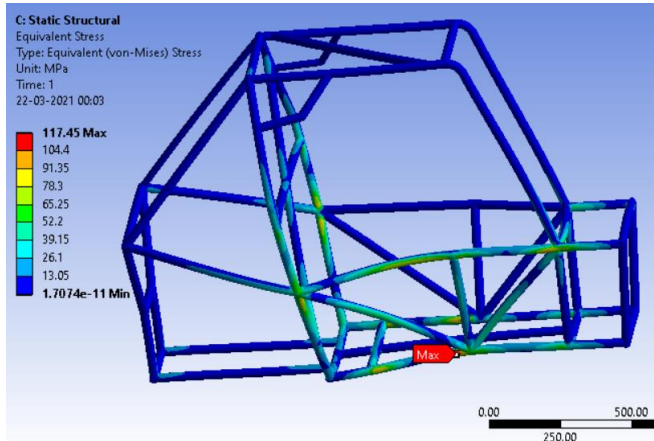

Figure14. Side Impact Stress

RESULT: The equivalent stress induced is 117.45 MPa. Hence, FOS is found to be 3.96 with maximum deformation of 2.26 mm which is within permissible limit.

4. Roll Over

This analysis is done to simulate a scenario where the vehicle rolls over i.e. the vehicle is considered to be dropped from a height. Under such conditions, the forces act on the front most members of the chassis.

Input parameters:

- We consider the total mass of the vehicle including the driver to be 250kg
- The vehicle is assumed to be dropped from a height of 10 feet or 3 metres.
- The impact time for front impact was considered as 0.15 seconds

Boundary conditions:

- The suspension points are fixed
- The force is applied on the top most members of the chassis

Calculations:

Mass of vehicle (m) = 250kg

Impact time (t) = 0.15s

Height (h) = 3m or 10ft

We know that, Potential Energy = Kinetic Energy

$$m \times g \times h = \frac{1}{2} \times m \times v^2$$

$$\text{Velocity, } v = \sqrt{2gh} = \sqrt{2} \times 9.81 \times 3 = 7.67 \text{ m/s}$$

$$\text{Kinetic Energy, K.E or Work (W)} = \frac{1}{2} \times m \times v^2$$

$$= \frac{1}{2} \times 250 \times 7.67^2$$

$$= 7353.61 \text{ N}$$

$$\text{Displacement (s) = Velocity (v) x time (t)}$$

$$\text{Or, } s = v \times t = 7.67 \times 0.15 = 1 \text{ m}$$

$$W = \text{Force (F) x Displacement (s)}$$

$$\text{Or, } F = \frac{W}{s} = 7353.61/1 = 7353.61 \text{ N}$$

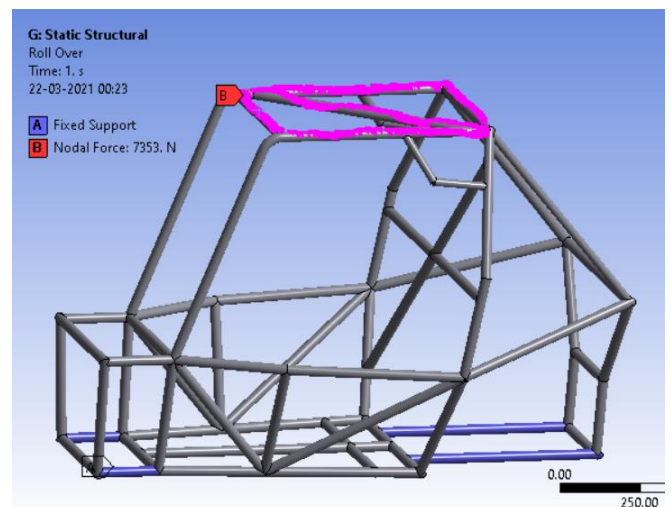

Figure15. Roll Over Boundary Conditions

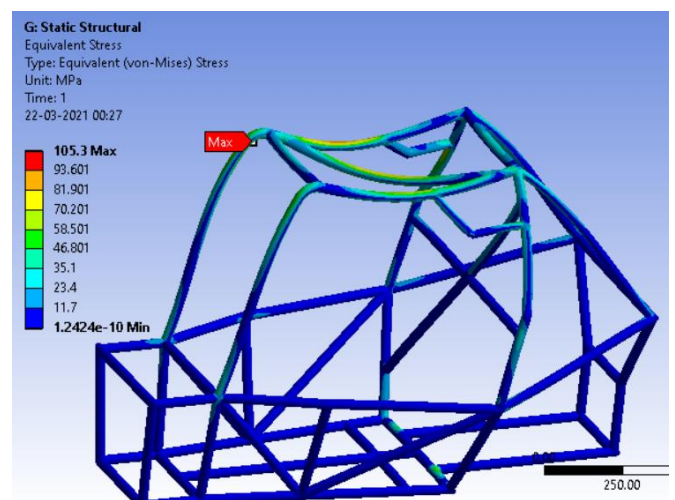

Figure16. Roll Over Deformation

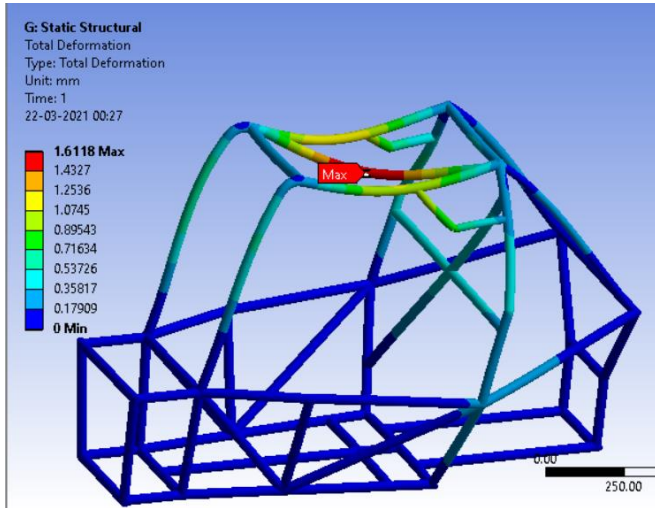

Figure17. Roll Over Stress

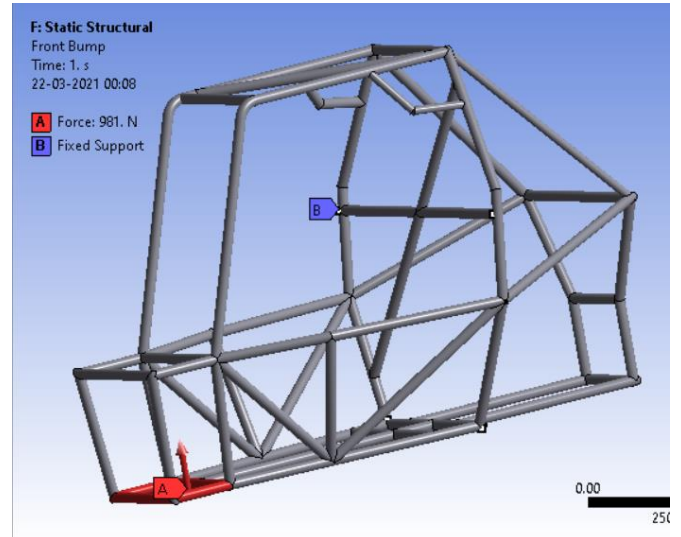

Figure18. Front Bump Boundary Conditions

RESULT: The equivalent stress induced is 105.3 MPa. Hence, FOS is found to be 4.36 with maximum deformation of 1.611 mm which is within permissible limit.

5. Front Bump

This analysis is done to simulate a scenario where the front wheels of the vehicle hits a bump on the road. Under such conditions, the forces act on the front suspension mounting members of the chassis.

Input parameters:

- We consider the total mass of the vehicle including the driver to be 280kg
- We consider the weight split over the front and rear axle to be 40:60

Boundary conditions:

- The rear suspension points are fixed
- The force is applied on the forward suspension mounting members

Calculations:

Mass of vehicle (m) = 250kg

Force on front axle = 40% of mass of vehicle x 9.81

$$= 0.4 \times 250 \times 9.81$$

$$= 981\text{N}$$

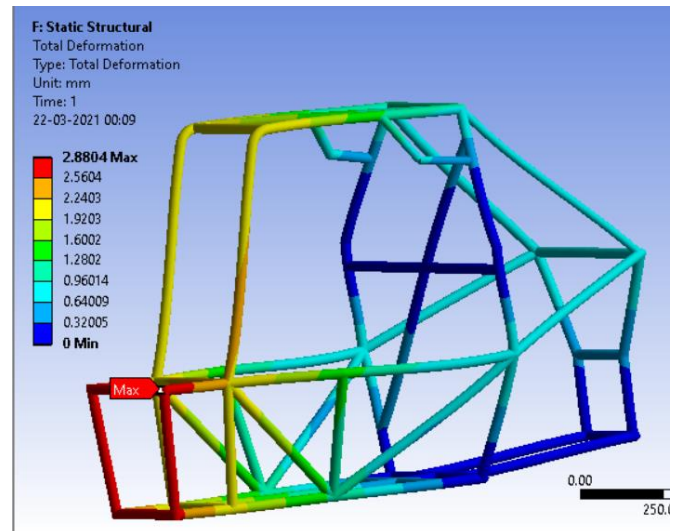

Figure19. Front Bump Deformation

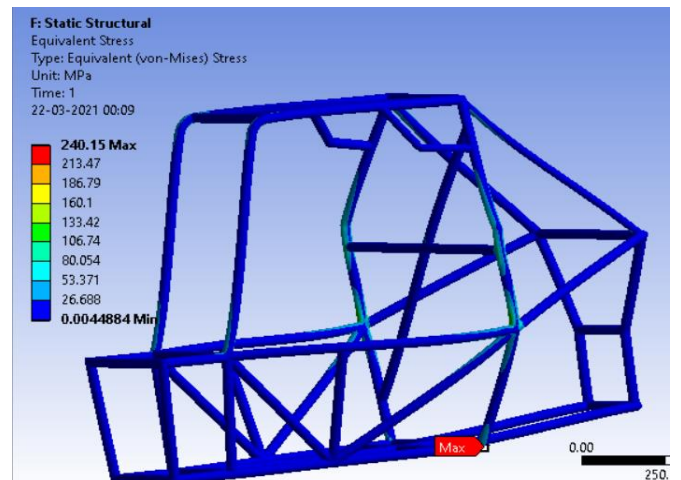

Figure20. Front Bump Stress

RESULT: The equivalent stress induced is 240 MPa. Hence, FOS is found to be 1.91 with maximum deformation of 2.88 mm which is within permissible limit.

6. Torsion

This analysis is done to determine the torsional stiffness during the cross bump at the front which occurs at event site. The main purpose of torsional analysis is to find greater roll cage stiffness to withstand dynamic suspension loads.

Input parameters:

- We consider the total mass of the vehicle including the driver to be 250kg
- We consider the weight split over the front and rear axle to be 40:60

Boundary conditions:

- The rear suspension points are fixed
- The force is applied on the forward suspension mounting members in opposite directions

Calculations:

Mass of vehicle (m) = 250kg

Force transfer from rear to front after applying the brakes is 60% of the total mass of the vehicle.

Therefore, Weight on front axle = 0.6 x 250 x 9.81

$$= 1471.5 \text{ N}$$

For safety, we consider a Force of 1500 N

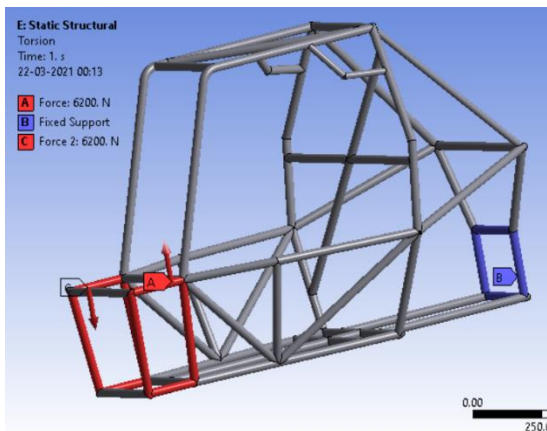

Figure21. Torsion Boundary Conditions

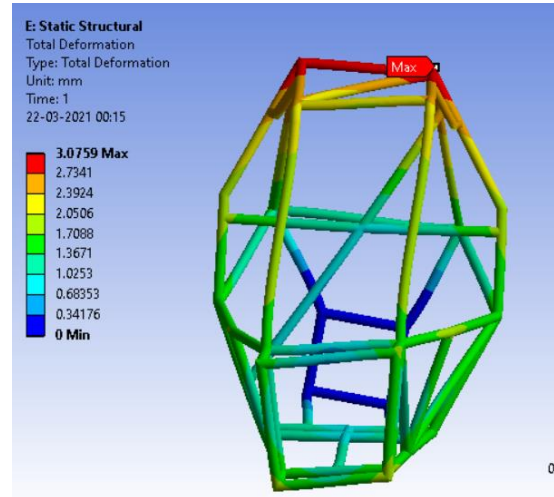

Figure22. Torsion Deformation

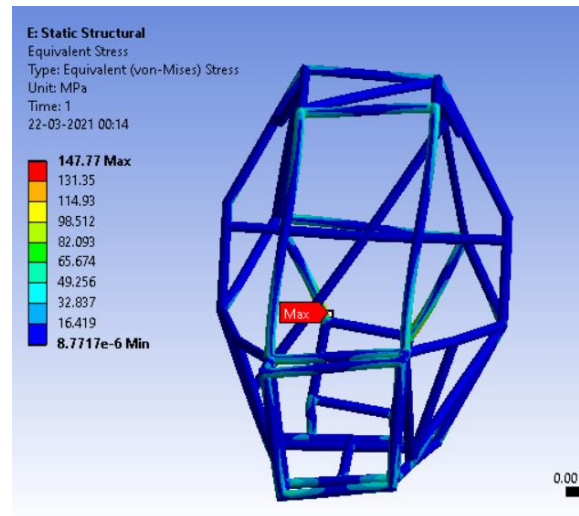

Figure23. Torsion Stress

RESULT: The equivalent stress induced is 147.77 MPa. Hence, FOS is found to be 3.11 with maximum deformation of 3.07 mm which is within permissible limit.

RESULT OF STATIC ANALYSIS

TEST	DEFORMATION (mm)	STRESS (MPa)	FOS
Front Impact	0.98	217.6	2.11
Rear Impact	1.39	104.7	4.3
Side Impact	2.66	117.45	3.96
Roll over	1.611	105.3	4.36

Front Bump	2.88	240	1.91
Torsion	3.07	147.77	3.11

CONCLUSION

This study shows the static analysis that has been carried out on the frame of the vehicle. The main objective of the test was to obtain optimum factor of safety in all the impact cases. During the study, frame of the all-terrain vehicle was analysed and optimized to achieve optimum factor of safety in all the impact cases which ensures that the frame of the all-terrain vehicle will be safe in all the conditions.

REFERENCES

- 1) Modeling and Simulation Study of BAJA SAEINDIA All-Terrain Vehicle (ATV) Using Integrated MBD-FEA Approach by Sahil Kakria, IVN sriHarsha, Milind Wagh.
- 2) Design and structural analysis of Baja ATV frame using conventional and composite materials by Shaik Mohammad Maliklal, YNV Santosh Kumar, Palle Prasad.
- 3) Design and Development for Roll Cage of All-Terrain Vehicle by D. Raina, R. Gupta, R.K.P.
- 4) Rulebook BAJA SAE INDIA 2021
- 5) Designing and Analysis of Roll Cage of an ATV by Amal Tom Kumbiluvellil and Abu Thomas Cherian.
- 6) Design and Analysis of the Roll Cage of an ATV by Harshit Raj.
- 7) Design & Manufacturing of Roll cage for allTerrain Vehicle – Selection, Modification, Static & Dynamic Analysis of Roll Cage for an ATV Vehicle by Upendra S. Gupta, Sumit Chandak, Devashish Dixit, Harsh Jain