

## SOLAR BASED GRASS CUTTER

Sherly Stalin<sup>1</sup>, Priyanka Sathe<sup>2</sup>, Pooja Rahate<sup>3</sup>, Pratiksha Farde<sup>4</sup>, Prof. S.K Srivastava<sup>5</sup>

<sup>1-4</sup>B.E. Student, Department of Electronics and Telecommunication Engineering, Shivajirao S. Jondhale College of Engineering, Dombivli East, Thane, Maharashtra 421204, India.

<sup>5</sup>Professor of Electronics and Telecommunication Engineering, Department of Electronics and Telecommunication Engineering, Shivajirao S. Jondhale College of Engineering, Dombivli East, Thane, Maharashtra 421204, India.

\*\*\*

**ABSTRACT-** The main purpose of technology is to form a value effective and ecofriendly grass cutting machine. Our aim is to check the varied developments within the grass cutter machines and their performance. the technology that is presently in use is by manual cutting. we tend to found that numerous styles of grass cutter obtainable in market square measure pass by suggests that of electrical, star and combustion engine. Grass cutters that square measure obtainable in market have several limitations to chop grass at some height. we tend to try to form a brand-new innovative conception that is especially utilized in agricultural field. we tend to square measure reaching to modify the grass cutting machine for the employment of agricultural field, to chop the crops within the field yet on cut the grass in any stadiums or utilized in traditional agriculture.

**KEYWORDS:** Solar grass cutter, Arduino Uno, Solar Panel, Robotic Lawn Mower.

### 1. INTRODUCTION

In the past and even heretofore, cutting of grasses within the faculties, sports tracks, fields, industries, hotels, public center, etc. was through with a sword. This methodology of manual cutting is time overwhelming as a result of human effort is required for the cutting. conjointly quality in cutting level was discovered victimization the manual cutting methodology. This work deals with the cutting of abundant (shrubs, stubborn, grass, flowers, leaves of trees) and conjointly with the planning of the machine, its potency, rigidity, mode of operation and also the choice of materials. the planning offers a bigger degree of versatile quality and exchangeability. Solar Grass cutting robotic vehicle power-driven by alternative energy that conjointly avoids obstacles and is capable of cutting grass while not the requirement of any human interaction.

### 2. EXISTING SYSTEM

The past technology of grass cutting is operated by hand by the utilization of hand devices like cut, these results into a lot of human effort and longer needed accomplishing the work. additionally, in previous methodology lack uniformity of the remaining grass. additionally, thanks to the utilization of engine high-powered machines will increase the air and sound pollution additionally this grass cutter need maintenance.

### 3. PROPOSED SYSTEM

Grass cutters are factory-made with wheels of variable diameters. one in all the foremost well-liked features a diameter of five.5 millimeter (732 in). The quantitative relation between the arc of the wheel and therefore the pressure applied with the tool has a very important touching on the degree of penetration. Average hand pressure with this size wheel typically provides sensible results. For a duller wheel on soft grass a bigger wheel (e.g., half dozen millimeter (fourteen in) would require no modification in hand pressure. A smaller wheel (3 millimeters (eighteen in)) is acceptable for cutting patterns and curves since a smaller wheel will follow incurvate lines while not dragging.

#### 4. PROPOSED FLOW CHART

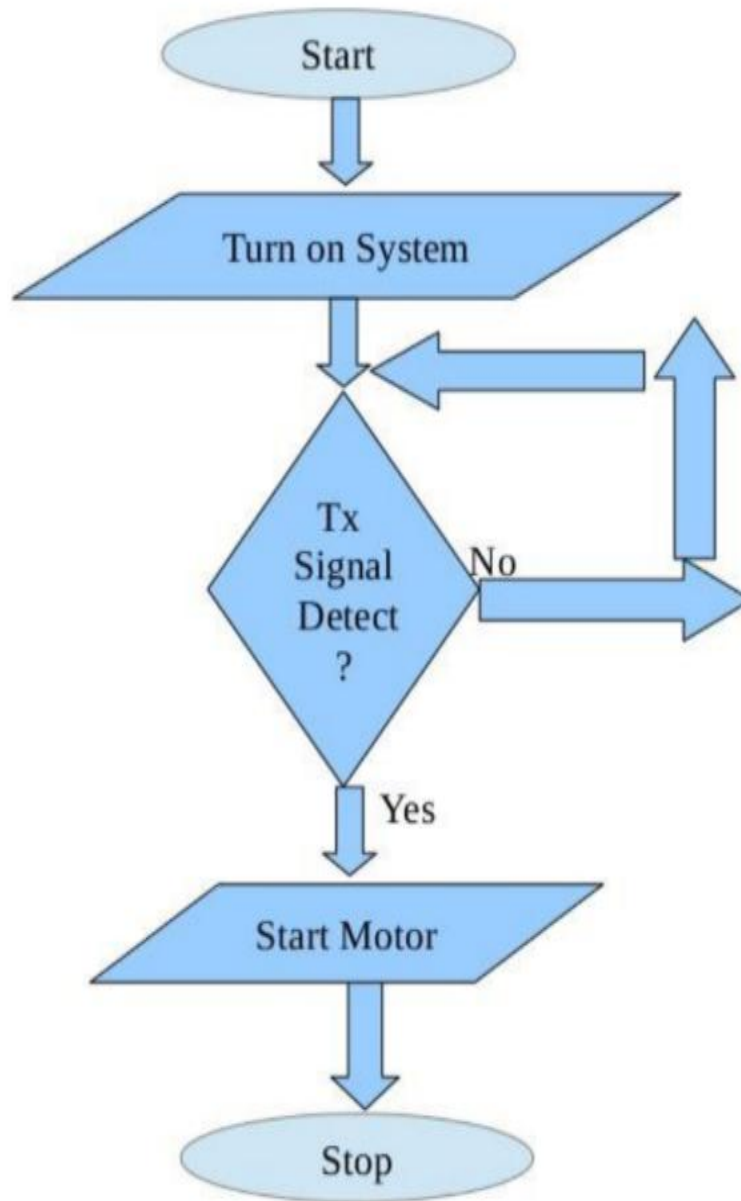

Figure 1. Flow Chart for Solar Grass Cutter.

## 5. BLOCK DIAGRAM

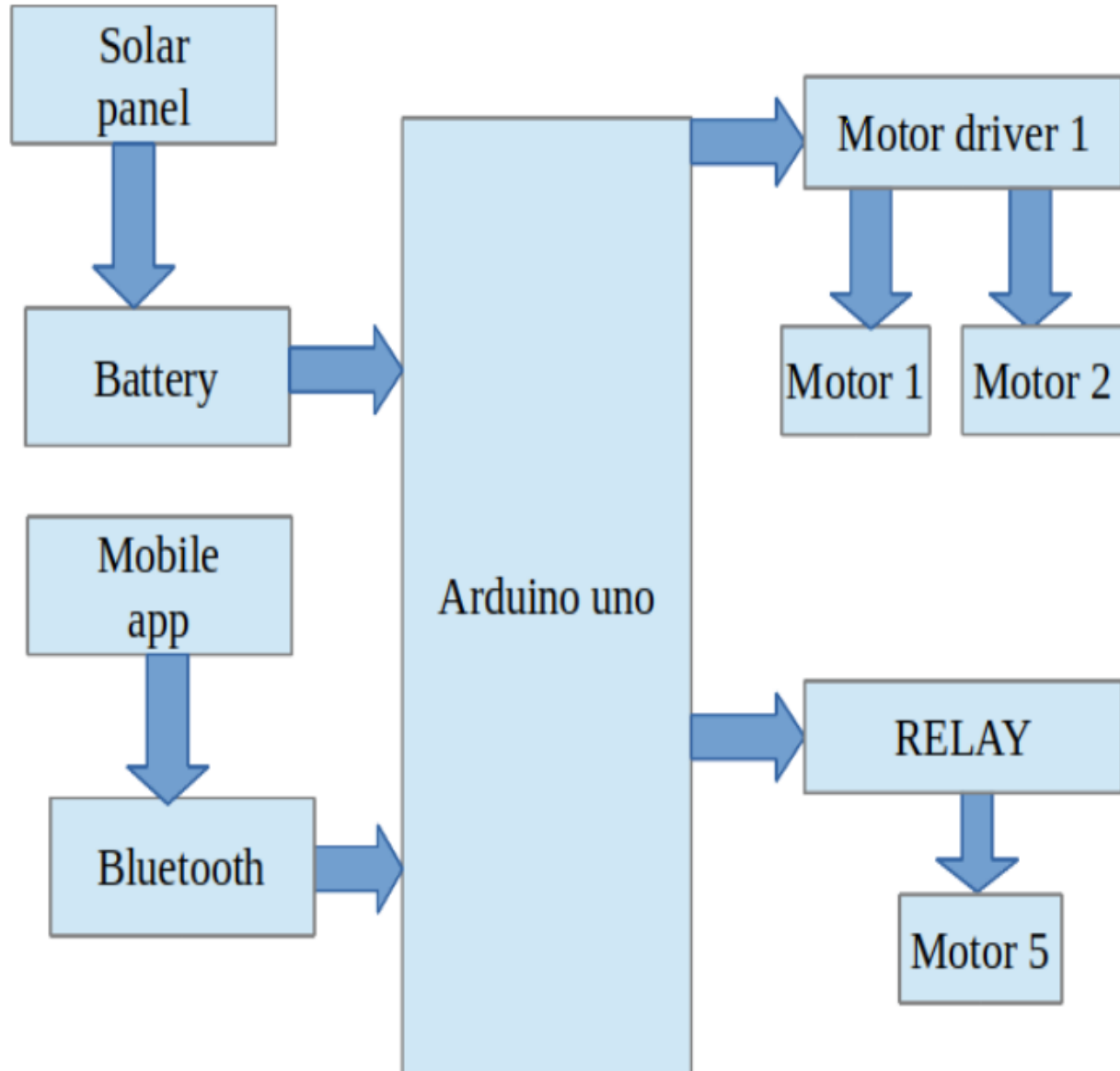

Figure 2. Block Diagram of Solar Grass Cutter

## 6. HARDWARE IMPLEMENTATION:

### 6.1. Arduino Uno

The Arduino Uno could be a microcontroller board supported the ATmega328. The Arduino Uno will be powered via the USB association or with associate external power supply. The Arduino Uno is programmed with the Arduino software system.



Figure 3. Arduino Uno.

### 6.2. L298N Motor Driver

The L298N is associate microcircuit that follows the H-bridge construct. To drive the motor anticlockwise, the pin Input one is low whereas the pin Input a pair of is high. the foremost notable feature here is its high-power supply though its input pins follow lower voltage levels. this implies you'll be able to power high voltage motors whereas dominant them with microcontrollers. The L298N has four inputs equivalent to the four switches.

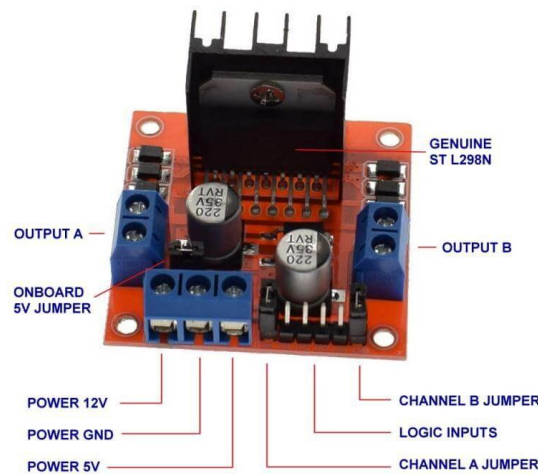

Figure 4. L298N Motor Driver.

### 6.3. Bluetooth Module

HC05 module is a simple to use Bluetooth SPP (Serial Port Protocol) module. it's designed for clear wireless serial connection setup.

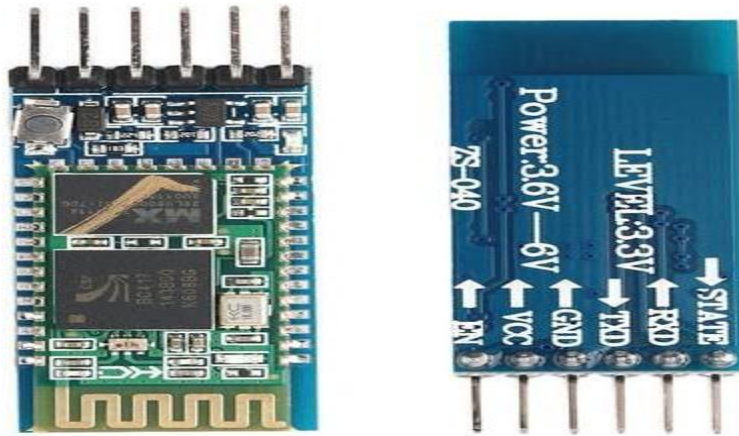

Figure 5. HC05 Bluetooth Module.

#### 6.4. 7805 Regulator

A voltage regulator IC maintains the output voltage at a relentless value. 7805 IC, a member of 78xx series of mounted linear voltage regulators want to maintain such fluctuations.

#### 6.5. Relay

A relay is an electrically operated switch. It consists of a collection of input terminals for one or multiple management signals, and a collection of operational contact terminals. Relays are used wherever it's necessary to regulate a circuit by an independent low-power signal, or wherever many circuits should be controlled by one signal.

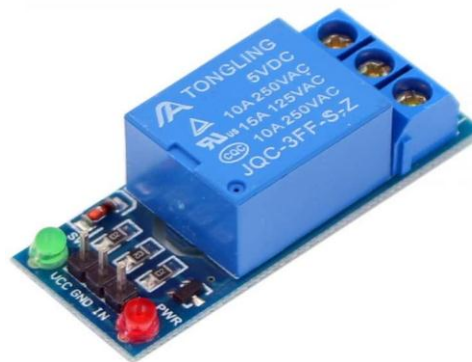

Figure 6. Relay.

#### 6.6. Solar Panel

Solar panel refers to a panel which is designed to soak up the sun's rays as a supply of energy for generating electricity or heating. A photovoltaic (in short PV) module could be a packaged, connected assembly of solar cells.



Figure 7. Solar Panel.

### 6.7. 1n4007 diode

A diode is a device that permits current flow through just one direction. That's, the current should flow from the Anode to cathode. The cathode terminal is often known by using a gray bar as shown within the image on top of.

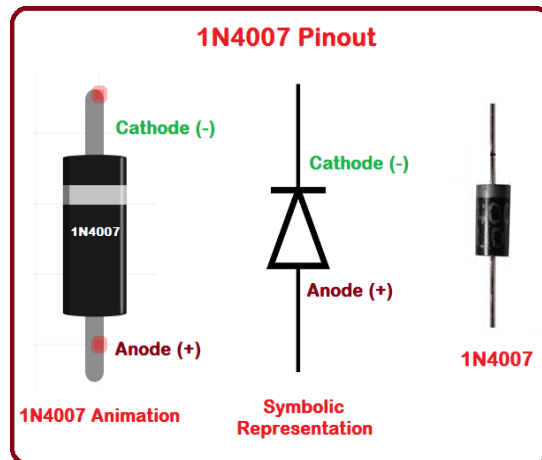

Figure 8. 1n4007 diode.

### 6.8. Ultrasonic Sensor

The ultrasonic detector detects objects inside its sensing vary, despite of these objects approaches the detector axially or move through the sound cone laterally. Ultrasonic sensors are accessible with switching outputs and/or analogue outputs, numerous output functions are offered according to type.



Figure 9. Ultrasonic Sensor.

## 7. SOFTWARE REQUIREMENT:

### 7.1. Arduino Software (IDE):

The Arduino Integrated Development environment - or Arduino code (IDE) contains a text editor for writing code, a message space, a text console, a toolbar with buttons for common functions and a series of menus. It connects to the Arduino and Genuine hardware to transfer programs and communicate with them. Programs written using Arduino code (IDE) are known as sketches. These sketches are written within the text editor and are saved with the file extension .ion. The editor has options for cutting/pasting and for searching/replacing text. The message space provides feedback whereas saving and exportation and additionally displays errors.

### 7.2. MIT App Inventor:

The MIT App creator user interface includes 2 main editors: the look editor and the blocks editor. The look editor, or designer, could be a drag and drop interface to get out of the weather of the applications interface (UI). The blocks editor is an environment in which app inventors can visually lay out the logic of their apps using color-coded blocks that snap together like puzzle pieces to describe the program.



Figure 10. MIT App Inventor.



## 8. ADVANTAGES:

1. Conservation of energy mechanism.
2. Reduction in consumption of fuels.
3. Improved stability with efficiency in operation.
4. Low cost and also has zero maintenance.
5. An eco-friendly electric generator.
6. The reduction in pollution by solar power.
7. It is a Natural energy source.

## 9. APPLICATIONS:

1. Cutting of grasses evenly.
2. Improvement in gardening.
3. Can be used in parks, gardens and pitches.

## 10. RESULTS:

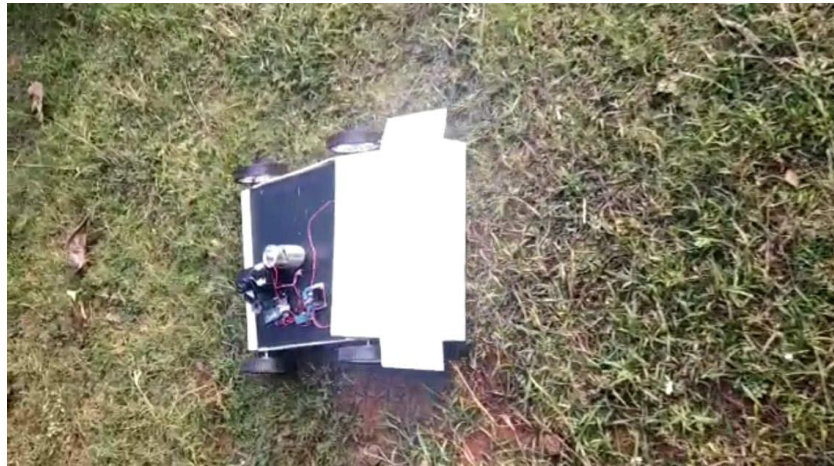

Figure 11. Solar Grass Cutter



Figure 12. Cutting view of Solar Grass Cutter



## 11. CONCLUSION:

Our project entitled manufacturing of solar powered grass cutter is successfully completed and conjointly the results obtained are satisfactory. It's going to be easier for the people who are near to take the project for any modifications. This project is further acceptable for a typical man as a result of its precision i.e., no fuel, no pollution and no fuel residue, less wear and tear because of less vary of moving components and this might be operated by pattern energy. The project that we've done will definitely reach the everyday families as a result of the grass could also be cut with minimum value with minimum time. Finally, this project may give an inspiration to the people who can modify and may acquire higher results.

## 12. REFERENCES:

- [1] <http://nevonprojects.com/fully-automated-solar-grass-cutter/>
- [2] S. Balameenakshi. S. Sumathi, Biometric Recognition of Newborns: Identification using Footprints, Proceedings of 2013 IEEE International Conference on Information and Communication Technologies (ICT 2013), 737-742, Tamil Nadu, India
- [3] <http://www.slideshare.net/kamerakranthikumar1/solar-grass-cutter>
- [4] Hai-Yang Cai, et al Newborn Footprint Recognition using Orientation Feature, Neural Computing & Applications: 1-9, Dec ICIC 2010.
- [5] Mr. Lokesh Mehta, Mr. Pawan Sharma Spy Night Vision Robot with Moving Wireless Video Camera. International journal of research in engineering technology and management (IJRETM), 2014.
- [6] Dhiraj Singh Patel Mobile Operated Spy Robot International journal of emerging technology and advanced engineering (IJETAE), 2013.