

Experimental and Analytical Study of Heat Transfer Characteristics using Helical Spring, Conical Spring and Conical Ring Inserts in Round Tube

A.R.Pawar¹, Prof.Dr.M.G.Harkare²

¹ ME student, Department of Mechanical Engineering, MGM's COE, Nanded, Maharashtra, India.

² Professor and Head, Department of Mechanical Engineering, MGM's COE, Nanded, Maharashtra, India.

Abstract - now days to achieve high heat transfer rate, different techniques have been used. This work presents an extensive experimental study on three types of inserts used in a smooth tube like Helical Spring, conical spring and Conical Ring. Isothermal pressure drop tests and heat transfer experiments under uniform heat flux conditions have been carried out. The computational fluid dynamic is also used to simulated different diameter of conical ring in ANSYS FLUENT 14 software.

The heat transfer in tube with conical convergent-ring inserts with $d=0.5D$ is found to be more as compared to smooth tube Friction factor reduces as the Reynolds number increases. This is because with increase in Reynolds number velocity increases and as friction factor is inversely proportional to velocity it decreases.

Key Words: Heat transfer enhancement, Wire coil inserts Heat exchangers Turbulence promoters, CFD

1. INTRODUCTION

Heat transfer is a discipline of thermal engineering that concerns the generation, use, conversion, and exchange of thermal energy and heat between physical systems. Heat transfer is classified into various mechanisms, such as thermal conduction, thermal convection, thermal radiation, and transfer of energy by phase changes. In the past decade, several studies on the passive techniques of heat transfer augmentation have been reported. Twisted tapes, wire coils, ribs, fins, helical coil etc., are the most commonly used passive heat transfer augmentation tools. The objective of this Project work is to analyses the heat transfer coefficient by using helical spring and conical ring inserts with different arrangement in tubes. Effect of inserts on tubes is analyzed for different Reynolds number with different flow rate. Simultaneously the friction factor is also analyzed for all these three types of inserts.

1.1 Heat transfer enhancement techniques

Heat transfer enhancement or augmentation techniques refer to the improvement of thermo hydraulic performance of heat exchangers. Existing enhancement techniques can be broadly classified into three different categories:

1. Passive Techniques
2. Active Techniques

3. Compound Techniques

1. Passive Techniques: These techniques generally use surface or geometrical modifications to the flow channel by incorporating inserts or additional devices. Heat transfer augmentation by these techniques can be achieved by using

- A] Extended surfaces
- B] Rough surfaces
- C] Additives for liquids

2. Active Techniques: This method involves some external power input for the enhancement of heat transfer and has not shown much potential owing to complexity in design. Various active techniques are as follows

- A] Mechanical Aids
- B] Surface vibration
- C] Fluid vibration
- D] Electrostatic fields

3. Compound Techniques: A compound augmentation technique is the one where more than one of the above mentioned techniques is used in combination with the purpose of further improving the thermo-hydraulic performance of a heat exchanger.

1.2 Project Work is based on Passive Enhancement Technique: Passive heat transfer augmentation methods as stated earlier does not need any external power input. The passive methods are based on the same principle. Use of this technique causes the swirl in the bulk of the fluids and disturbs the actual boundary layer so as to increase effective surface area, residence time and consequently heat transfer coefficient in existing system. Following Methods are used generally used,

1. Inserts
2. Extended surface
3. Surface Modifications
4. Use of Additives

Table-1: Thermal Properties of water

Sr.No	Property	Water
1	C, J/kg K	4179
2	ρ , kg/m ³	997.1
3	k, W/m K	0.65
4	α , m ² /s	1.45×10^{-7}

2. MODELLING OF CONICAL RING INSERT

In the present study the three dimensional geometry is created using SOLIDWORKS software, the pre-processor used to construct the flow geometry, along with the mesh generation for solving the continuity and the equation of motion. The storage model has been solved by using commercial CFD software with package FLUENT, to solve the equations by numerical methods for the geometry constructed.

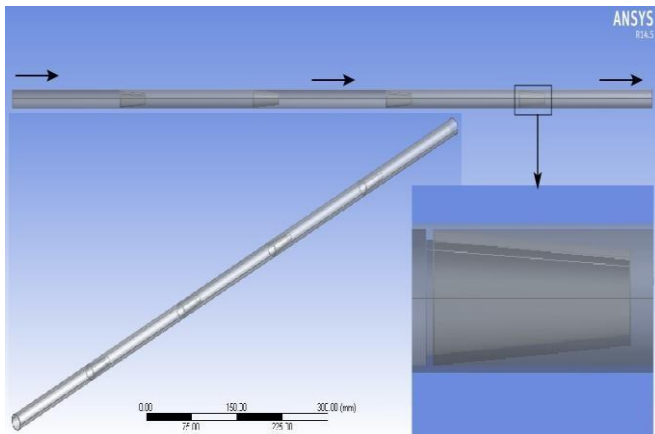

Fig 1. Sketch of conical ring of CFD analysis

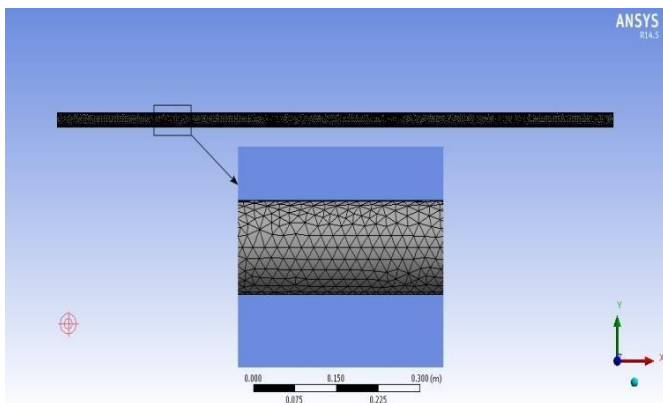

Fig 2. Discretized computational domain

3. Experimental setup

Fabrication

The experimental set up is constructed and fabricated with great care. The set consists of water tank, pump, by-pass valve and rotameter heating coils nichrome wire, thermocouples, U-tube manometer, mild steel and aluminum inserts.

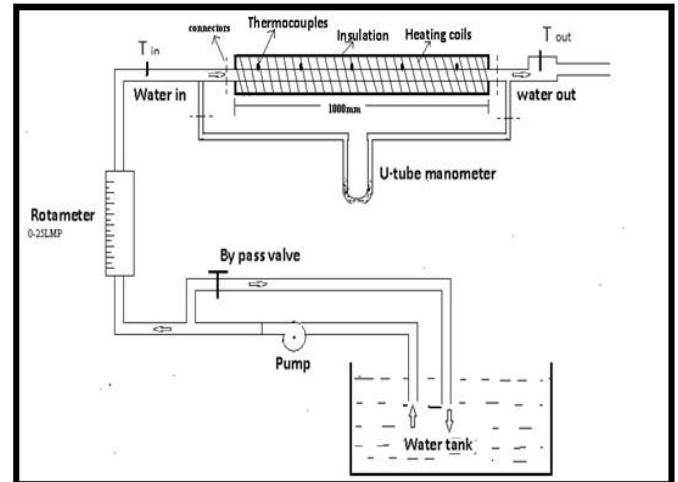

Fig.3 Line diagram of set up

3. Experimental procedure

After completing the fabrication of the experimental setup firstly filled the water tank by using the tap water and then starts the water pump. Set the current and voltage range in ammeter and voltmeter respectively so that it gives the uniform heat flux to the tube at wall temperature range of 43°C to 47°C. And now with setting the flow rate of the working fluid at 4 lpm, 6 lpm, 8 lpm, 10 lpm, 12 lpm, 14 lpm, and 15 lpm. The setup would be run continuously till the steady state achieve. After achieving the steady states take the reading of temperature at the inlet and outlet of tube without using any inserts i.e. smooth tube. And also take the reading of tube surface wall temperatures by using digital temperature controller... Take the reading of pressure drop across the test tube section by using the U-tube manometer. The experimental procedure repeated with changing the valve of the inlet working fluid at different flow rate, till the steady state is achieved. After achieving steady state in smooth tube the same experimental procedure is repeated for different inserts.

4. Actual set up photo



Fig.4 Actual set up diagram

5. Design Parameter



Helical Spring Insert	Conical Spring Insert	Conical ring Insert
		
Wire diameter (d) = 1.5 mm	Maximum diameter(D) = 19.2 mm	Ring thickness = 1.5 mm
Mean diameter (D) = 19.2mm	Diameter of wire(d)= 1.5 mm	Small end diameter (d) = 0.5D, 0.7D
Material=Aluminum	Material = Aluminum	Material = Mild Steel
Length of spring 40mm	Length of spring=40 mm	Length of ring = 40 mm
Pitch (p)= 6mm and 9mm	Pitch=6mm and 9mm	(d) = 0.5D, 0.7D

Table 2: design parameter of every Inserts

5.1 Sample calculation for smooth tube

1) Constant Heat flux:

$$Q=VI$$

2) Properties at mean bulk temperature.

$$T_{mean} = (T_{in} + T_{out}) / 2$$

3) Area of tube (A)

$$A = \pi / 4 \times D^2$$

4) Mass flow rate (m)

$$m = \rho AV$$

5) heat transfer coefficient (h)

$$Q = m \cdot c_p \cdot (T_{b2} - T_{b1}) = h \cdot A_s \cdot (T_{wo} - (T_{in} + T_{out}) / 2)$$

Where,

Q= heat transfer rate.

h= heat transfer coefficient W/m²-k

A_s=Heat transfer area m² = 0.064 m²

T_{in}= Water temperature at inlet °C

T_{out}= Water temperature at outlet °C

T_{wo} = Average tube surface temperature

7) Nusselt Number (Nu)

$$Nu = h \times D / k$$

8) Pressure drop (manometer reading)

$$(\Delta P) = \rho \times g \times h$$

9) Friction factor (f)

$$f = \Delta P \times 2 \times D / L_t \times \rho \times v^2$$

5.2 Theoretical heat transfer characteristics calculation (for smooth tube)

1) Mean water velocity (U_m)

$$U_m = m / A_f$$

2) Theoretical Reynolds's Number (Re)_{th}

$$Re = (\rho \times D_i \times U_m) / \mu$$

3) Prandtl number (Pr)

$$Pr = (\mu \times C_p) / k$$

4) Friction factor (f)_{th}

$$f = (0.79 \times \ln Re - 1.64)^{-2}$$

5) Nusselt Number (Nu)_{th}

$$Nu = (f / 8) \times (Re - 1000) \times Pr / (1 + 12.7(f / 8)^{1/2} (Pr^{2/3} - 1))$$

6) Theoretical heat transfer coefficient (h)_{th}

$$(Nu)_{th} = h_{th} \times D / k$$

6) Results and Discussion

The experiments were carried out on the test ring initially smooth tube without using any inserts and the different heat transfer characteristics were calculated and then the same is done using helical spring inserts, conical spring inserts and conical ring inserts. The experimentation is divided in following cases.

- Case I: Experimentation on test tube without using any inserts.
- Case II: Experimentation on test tube with helical spring inserts with pitch 9 mm and 6 mm respectively (Number of inserts use=4)
- Case III: Experimentation on test tube with conical convergent spring inserts with pitches 9 mm and 6 mm respectively (Number of inserts use=4)
- Case IV: Experimentation on test tube with conical convergent-ring inserts. with d=0.7D and d=0.5D respectively (Number of inserts use=4)

Based on the observations recorded while experimentation, following parameters are calculated.

- Mass flow rate for all four cases.
- Heat transfer coefficient for all four cases.
- Nusselt number for all four cases.
- Reynolds Number for all four cases.
- Pressure drop for all four cases.
- Frictional factor.
- Percentage increment in average HTC for all four cases.

Based on the above calculations following graphs are plotted for interpretation of performance

- Heat transfer coefficient Vs Reynolds No. For all cases
- Nusselt No. Vs Reynolds No. for all cases
- Friction factor Vs Reynolds No. for all cases

6.1 Heat transfer coefficient Vs Reynolds No.

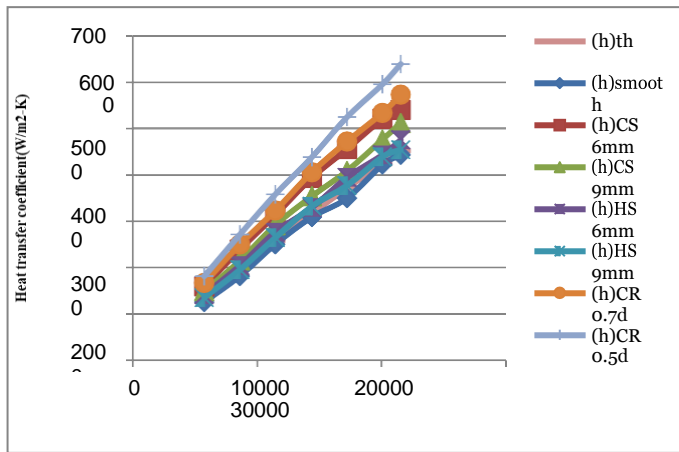

Fig: 5 Heat transfer coefficient Vs Reynolds Number

From the Fig. 5 it is observed that the heat transfer coefficient increases with increase in Reynolds number. As Reynolds number increases, the water flow will cause more turbulence, so due to which the heat transfer rate will increase. From the Fig. 5 it is observed that the tube without using any insert gives less heat transfer coefficient than with the use conical spring inserts and helical spring inserts.

convergent ring insert ($d=0.5D$) as compared to conical convergent spring inserts and helical spring inserts.

6.3 Friction factor Vs Reynolds No

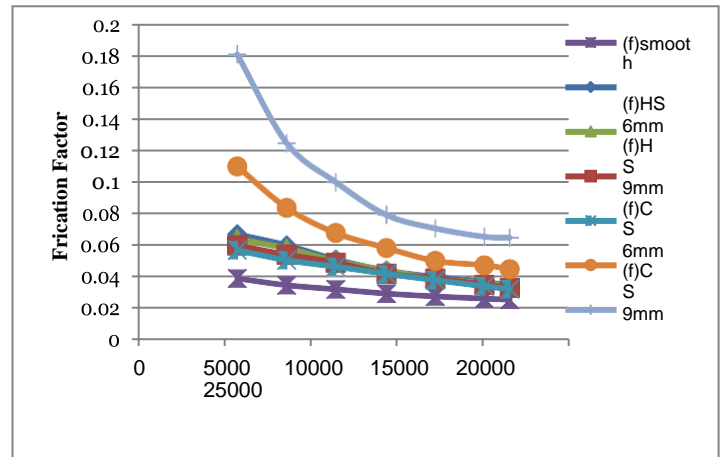

Fig.7 Friction factor Vs Reynolds Number

From the Fig.7 it is observed that as Reynolds increases there is decrease in friction factor is observed. This is because friction factor is inversely proportional to the velocity. So as velocity increases (i.e. Reynolds number increases) friction factor will decrease. From fig.7 it is observed that least friction factor is obtained in smooth tube without using any inserts. In conical convergent ring inserts ($d=0.5D$) give maximum friction factor.

6.2 Nusselt No. Vs Reynolds No. for all cases

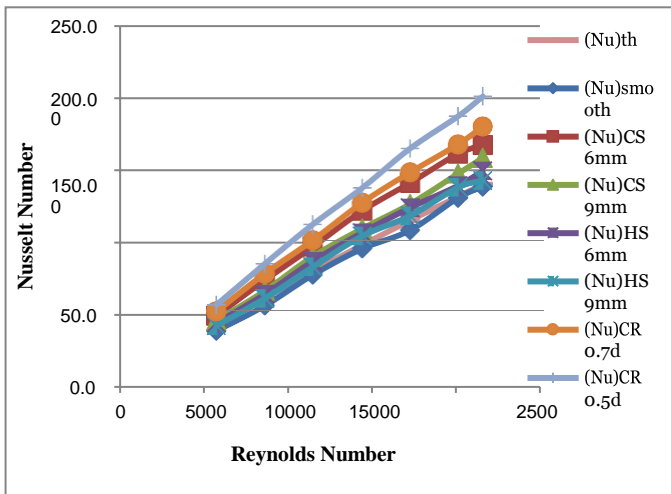

Fig:6 Nusselt Number V/s Reynolds Number

From the Fig.6, it is observed that there is increase in Nusselt number with Reynolds number. As Reynolds number increases the water flow will cause more turbulence due to which heat transfer rate will increase. As heat transfer coefficient is directly proportional to Nusselt number, $Nu = hD_h / K$ i.e increase in heat transfer coefficient increases the Nusselt number. From fig 6 it is observed that maximum Nusselt number is obtained for conical-

7. Computational fluid dynamic Result:

Geometry and computational fluid domain the schematic diagram of computational fluid domain is as shown in following fig.

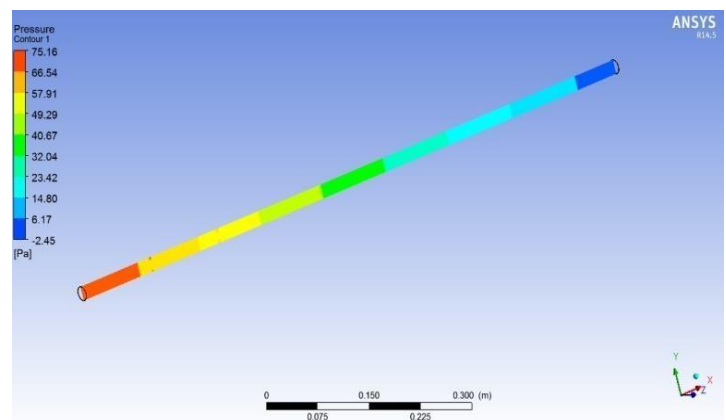

Fig: 8 Pressure distribution diagrams for Smooth Tube

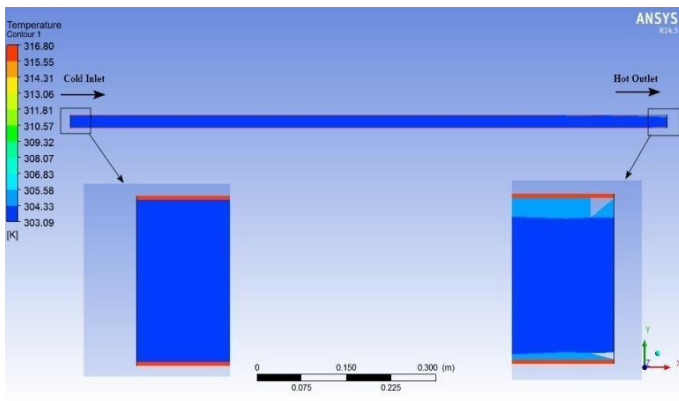

Fig 8: Temperature distribution diagrams for smooth Tube

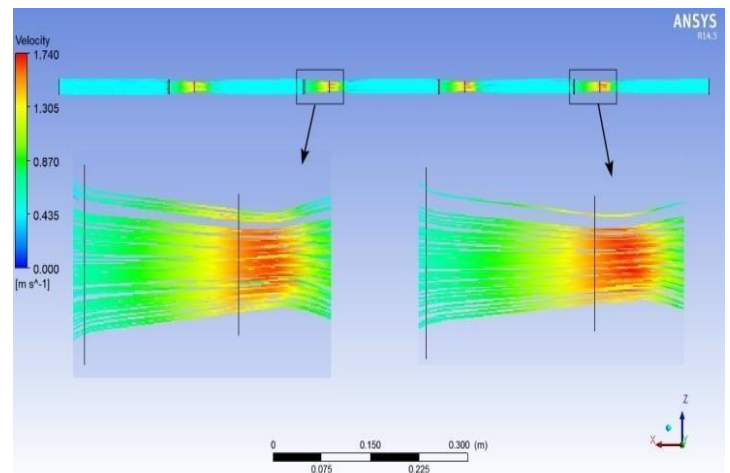

Fig 11: Velocity distribution diagrams for conical ring (d=0.5D)

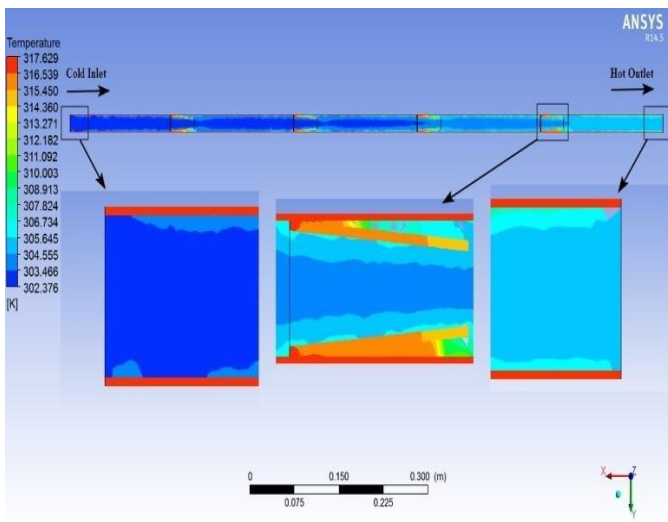

Fig 9: Temperature distribution diagrams for conical ring (d=0.5D)

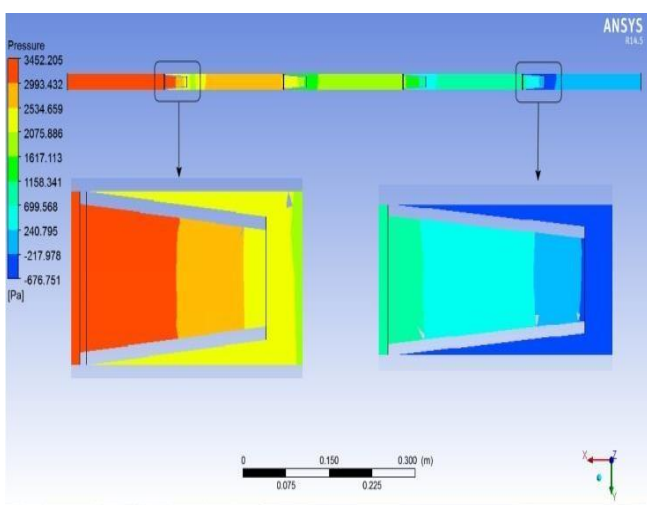

Fig 10: Pressure distribution diagrams for conical ring (d=0.5D)

7. Conclusions

Experimental study of different inserts have been carried out in the circular tube to study the effect of conical spring inserts, helical spring inserts and conical ring inserts on heat transfer enhancement friction factor. Also analysis is done with the help of ANSYS FLUENT 14. The thermal performance parameter overall heat transfer coefficient has been determined. Also, the effect of friction factor on heat transfer rate is determined.

Some of main conclusions are noted below.

- 1) The heat transfer in tube with conical convergent-ring inserts with $d=0.5D$ is found to be more as compared to smooth tube i.e. without using any inserts.
- 2) From the experimental study and CFD analysis it is observed that the percentage increase in average heat transfer coefficient of water 45.73% higher for conical convergent-ring inserts ($d=0.5D$).
- 3) The increase in heat transfer occurs because more turbulence is generated within the tube by using different shaped of inserts as compared to without using inserts.
- 4) Friction factor reduces as the Reynolds number increases.
- 5) As the numbers of inserts are used in tube are more than 4 it gives maximum heat transfer coefficient but it increases the pressure drop in tube due to this maximum pressure drop maximum friction factor is to be found.

8. REFERENCES

- [1] Alberto Garcia, Juan P. Sloan, Pedro G. Vicente, Antonio Veda, "Enhancement of laminar and transitional flow heat transfer in tubes by means of wire coil inserts". *International Journal of Heat and Mass Transfer* 50 (2007) 3176–3189.
- [2] P. Promvonge, "Heat transfer behaviours in round tube with conical ring inserts". *Energy Conversion and Management* 49 (2008) 8–15.
- [3] Bodius Salam, SumanaBiswas, ShuvraSaha, Muhammad Mostafa K Bhuiya , "Heat transfer enhancement in a tube using rectangular-cut twisted tape insert". 5thBSME International Conference on Thermal Engineering.
- [4] P.Sivashanmugam, S. Suresh, "Experimental studies on heat transfer and friction factor characteristics of laminar flow through a circular tube fitted with helical screw-tape inserts". *Applied Thermal Engineering* 26 (2006) 1990–1997.
- [5] P. Bharadwaj, A.D.Khondge, A.W. Date, "Heat transfer and pressure drop in a spirally grooved tube with twisted tape insert". *International Journal of Heat and Mass Transfer* 52 (2009) 1938–1944.
- [6] HaydarEren, NevinCelik, SeybaYildiz, Aydın durmus, "Heat transfer and friction factor of coil-spring inserted in the horizontal concentric tubes". *Journal of Heat Transfer* January 2010, Vol. 132/011801-11.
- [7] Naga Sarade S.,K.K. Radha, A. V. S. Raju, "Experimental investigations in a circular tube to enhance turbulent heat transfer using mesh inserts". *ARPJ Journal of Engineering and Applied Sciences* VOL.4, NO.5, July2009.
- [8] Ahmet Tandiroglu , "Effect of flow geometry parameters on transient heat transfer for turbulent flow in circular tube with baffle inserts". *International Journal of Heat and Mass Transfer* 49(2006) 1559-1567.
- [9] S.S.Joshi and V.M.Kriplani, "Experimental Study of Heat Transfer in Concentric Tube Heat Exchanger with Inner Twisted Tape and Annular Insert". *International journal of advanced engineering science and technologies*.VOL. NO.10, Issue No.2, 334-340. (IJAEST).
- [10] WatcharinNoothong, SmithEiamsaard, Pongjet Promvonge, "Effect of Twisted-tape Inserts on heat transfer in a tube". The 2nd joint International conference on "Sustainable Energy and Environment (SEE2006)".
- [11] C. P. Kothandaraman and S. Subramanian, "Heat transfer Data Book"