

# Design Optimization and Analysis of Light Weight Sandwich Honeycomb Panels for Aircraft Applications

S.N.Abhinav<sup>1</sup>, Madhava Varma Budharaju<sup>2</sup>, Dr. S. Adinarayana<sup>3</sup>

<sup>1</sup>A Student at MVGR College, Vizianagaram,

<sup>2</sup>Senior Assistant Professor, Department of Mechanical Engg, Mvgr College, Vizianagaram

<sup>3</sup>Head of the Department, Dept. of Mechanical Engg., MVGR College of Engineering (A), Vizianagaram

\*\*\*

**Abstract:** We humans, are always on the trail of inventions and innovations. The innovations cause the trail to increase within the advancement of materials. The advancement causes the path to expanding inside the progression of materials. Progression of material is essentials for boosting the fuel economy of modern aircraft and also maintaining safety and performance. Since it takes less capacity to hasten a lighter object than a heavier one. A 10% reduction in aircraft weight can result in a 6%-8% fuel economy enhancement. The reduction of weight will increase in the development of the overall performance of aircraft and in saving the fuel. The movement of aircraft is through the air, so we need the material to be lightweight and good strength ratio also. Honeycomb materials have been developed to resist the high temperature and also have good resistance to fatigue strength. Honeycomb sandwich panels are orthotropic which implies they grow in longitudinal, radial, and tangential directions. In this article, we compared the aluminum honeycomb core with the Hastelloy X honeycomb core. The sandwich is a composite structure, the materials are orthotropic, and the core shear modulus is low; therefore, the shear deformations must be checked. So, the design of the sandwich composite structure was done in Catia software, and analysis was done in ANSYS software. The composite sandwich panel was tested on three conditions (I) uniform pressure application (II) One End Fixed (III) Both the Ends Fixed. Based on the results we conclude that Hastelloy X has good stress factor, fatigue strength life cycle, and good thermal resistance when compared with aluminum.

## 1. Introduction

Material Technology is an advancing innovation that constantly increases modern materials with properties that leads to modern applications. A nickel-based superalloy is a strong metal and highly corrosive resistant. In the rapid increase of technology, new advancing materials are getting developed which are lightweight and highly corrosive resistant. Hastelloy X is one of them and it is a nickel-based superalloy that is used in the aircraft application. Hastelloy x is used in the honeycomb structure as a form of seals in the aircraft. As the Hastelloy X metal is lightweight and corrosive resistant, so it is used in the application of aircraft. Aluminum is also one of the finest metals which is lightweight and used mostly in automobile applications. The basic reason for using the honeycomb structure is to save weight, however, smooth skins and excellent fatigue resistance are also attributes of the honeycomb panel. But honeycomb used in the sandwich composite beams gives more bending stiffness and strength that is combined with low weight [1][15]. The concept of sandwich composite structure will increment the range of merged functions such as thermal and sound insulation, excellent features like fire safety, good energy absorption, directional properties of face sheets enabling optimized design, and production of complex and smooth hydrodynamic surfaces [2][3][5][18]. M.N.F Saniman[10] M.Sugaraneswaran [11] Z.Hryciow [12] has used honeycomb structure for comparing it with other conventional geometry designs to validate the surface area is more than the honeycomb.

Mokhtar [6] made a honeycomb bending analysis on the symmetrically laminated plates on the composite solid element using ANSYS. He used the shell 99 and shell 46 elements and did the deflection and von misses stress analysis. He concluded that stress is induced due to the effect of stacking. Both Ganesh [7] did the structural analysis on honeycomb panels of 100mm x 100mm choosing three different materials (Aluminium alloy, steel & Titanium). He concluded that aluminum is best when compared with others in the Strength weight ratio. Shaik Nazeer [8] analyzed comparing between the aluminum and titanium honeycomb using ANSYS. He concluded that the cost of titanium is very high so the use of aluminum which is low cost and good strength can be considered as the best. Dr.Flora Jessica[9] has made a pressure analysis on the aluminum and titanium honeycomb core using ANSYS.

W.miller and Aspron D has stated the importance of buckling load resistance and explores the buckling behavior of the honeycomb structure[13][14]. Crupi has studied the mechanical behavior of honeycomb structure under bending and impact loading and concluded that the strength increases with GFRP outer skins which are designed for sandwich applications[16]. Adams has investigated the damped analysis of aluminum and Nomex honeycomb material and concluded the shear moduli are similar for both the materials.[17][19]. M.Gotoh studied the crush behaviour of honeycomb cell shape and the foil thickness by using numerical simulation[20]. Muhammad Kashif khan has compared the material properties between aluminium facing honeycomb panel and glass fibre facing honeycomb panel. He also studied

the bonding strength of the face joint and core joint[21].Ahamed abbabi studied the analysis of honeycomb structure using 4 points bending stress on the honeycomb sandwich panel[22]. Paulus studied the deformation analysis on honeycomb core using quasi-static and dynamic loading factors[23].k.kantha rao made the experimental analysis on the comparison of aluminium rod and aluminium honeycomb core[24].

## 2 Experimental Procedure

- (i) **Design Methodology:** The first stage or preliminary level of design is to create a simple hexagonal cell structure using CATIA software design tools. After the design of the hexagonal cell, we need to assemble the group of hexagonal cells to a certain length to form a flat honeycomb structure. Now the second stage of the design is to create a rectangular plate for the honeycomb structure so that it looks like a sandwich panel.
- (ii) **Problem Definition:** To perform an accurate analysis an engineer must determine some information such as structural loads, geometry, support conditions, and material properties. The result of such analysis typically includes deformation, stress, and displacement. This information is then compared to criteria that indicate the condition of failure.
- (iii) **Material Selection:** Once the design phase in CATIA is completed then we convert the CATIA file to IGES format so that the design file can be accessed in any analysis applications such as ANSYS, NX, SOLID EDGE, SOLID WORKS, etc. The design file is opened in the ANSYS software and in the material section, selection of materials like aluminium and Hastelloy X are selected.

## 3. Modelling Phase

In the modeling phase, we used CATIA software as it delivers the unique ability not only to model any product but to do so in the context of its real-life behavior: design in the age of experience.

### 3.1.1 Modelling of Hexagonal honeycomb structure

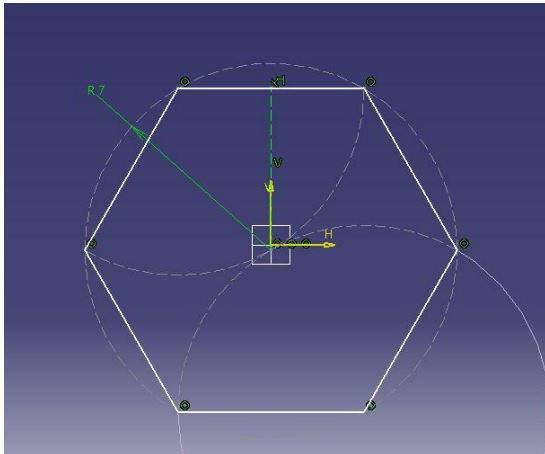

Fig 3.1 Hexagonal cell

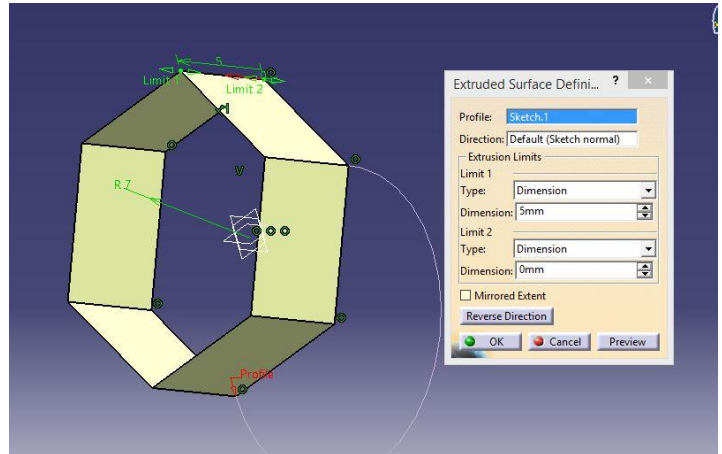

Fig 3.2 Extruded Hexagonal cell

### Dimensions of Hexagonal Cell

- Edge Length = 3.5mm
- Radius = 7mm
- Thickness = 0.5mm

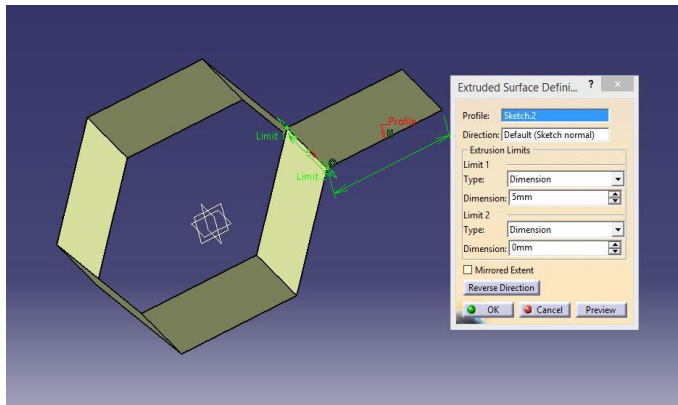

Fig 3.3 Creating offset for pattern design

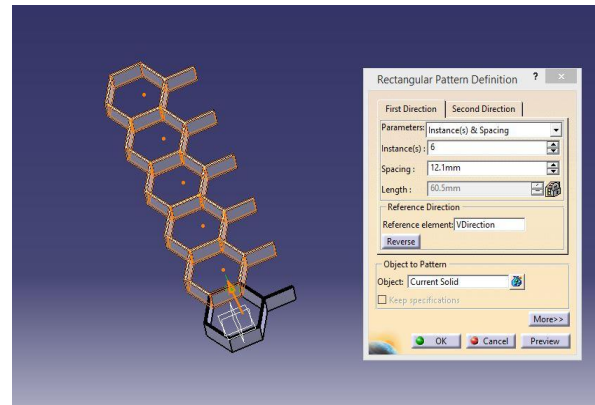

Fig 3.4 Rectangular pattern of hexagonal cell in V-Direction

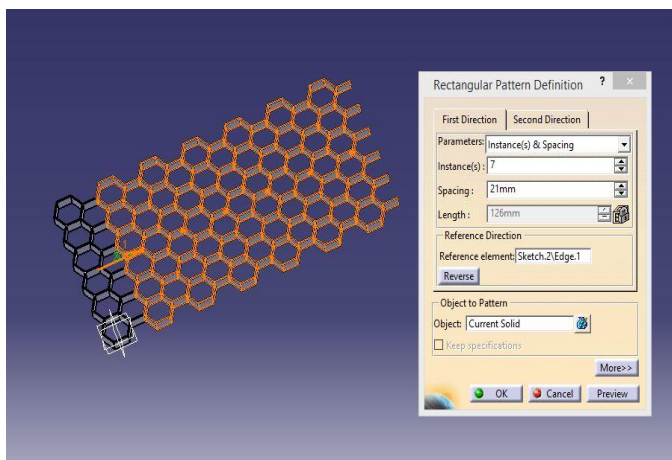

Fig 3.5 Rectangular pattern of hexagonal cell in H-Direction

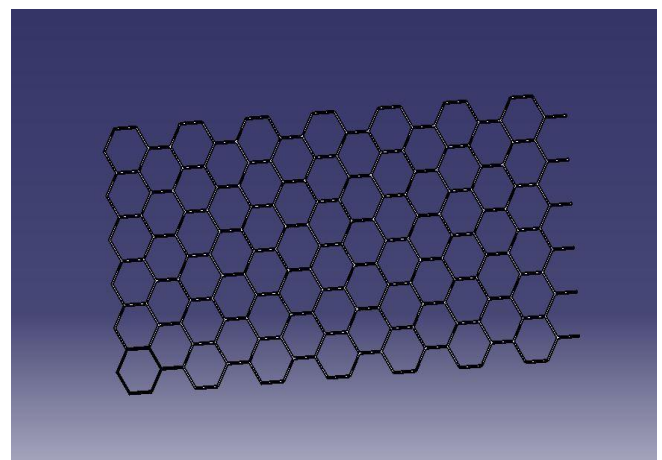

Fig 3.6 Hexagonal Honeycomb Structure

### Modeling of Rectangular Plate

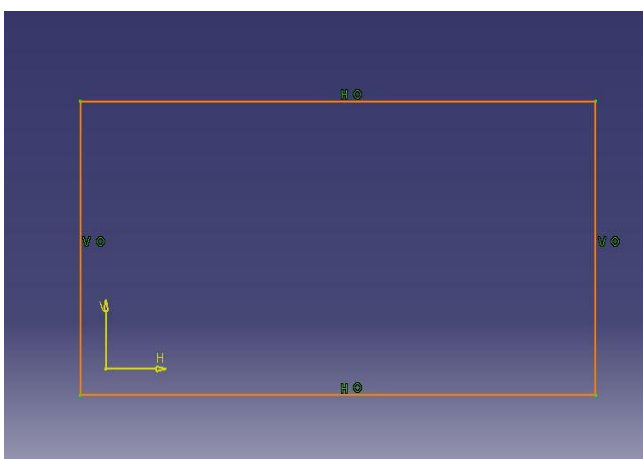

Fig 3.7 Rectangular Plate

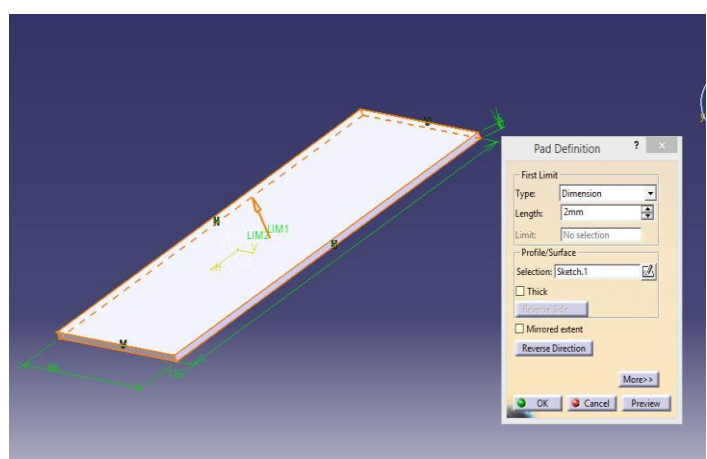

Fig 3.8 Pad definition on Rectangular Plate

### Dimensions of Rectangular Plate

- Length = 140mm
- Width = 70mm
- Thickness = 2mm

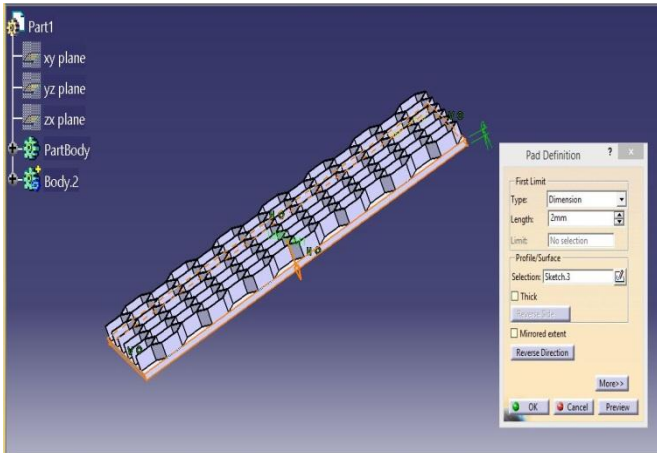

Fig 3.9 Rectangular Plate as Bottom face sheet

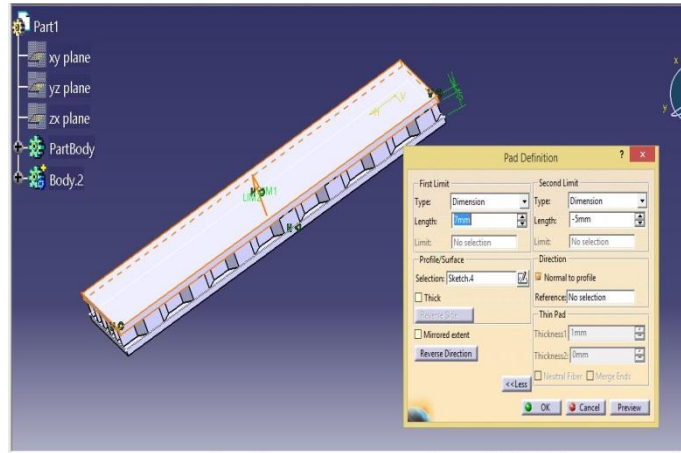

Fig 3.10 Rectangular Plate as Top face sheet

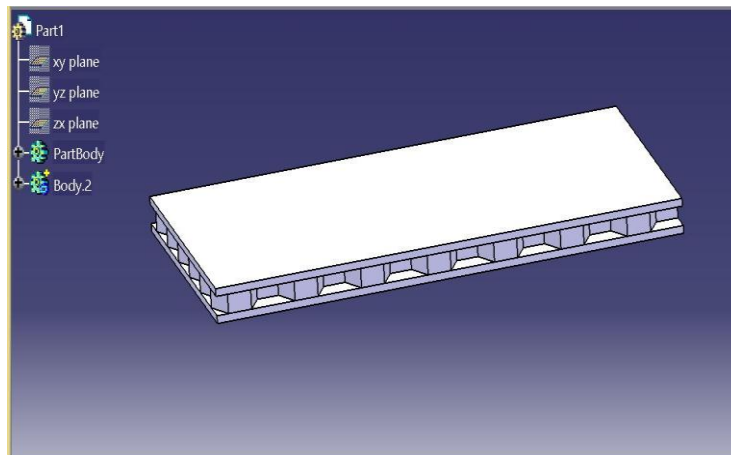

Fig 3.11 Sandwich Honeycomb Structure

## Anslys Analysis

ANSYS is engineering simulation software Dr. John A. Swanson has been developed Swanson Analysis System, Inc. (SASI) in 1970. Its main was to improve and advertise fixed component analysis software for essential behaviour of structure that could stimulate Static (stationary), Dynamic (moving), and thermal (heat transfer) problems.

## 4. Result and Discussions

The Structural analysis done by the following cases, in each case consider deformation, stress, and strain.

### 4.1 Case 1: Pressure

In this case, one end of the composite material is fixed and the pressure is applied on the other end. By this experiment we can get the total deformation, von misses stress that is developed in the composite materials.



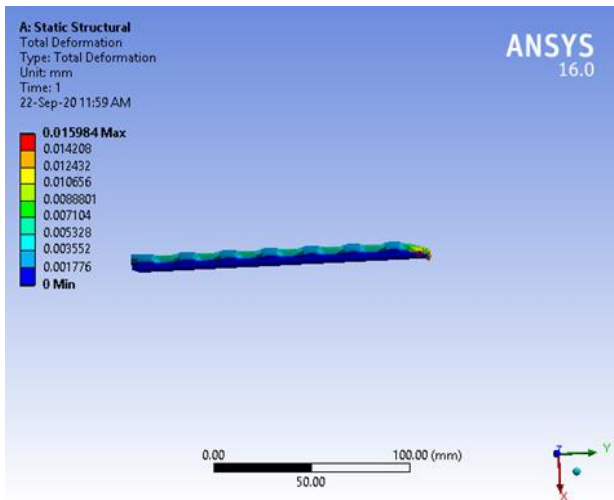

Fig 4.1.1 Total deformation of aluminium

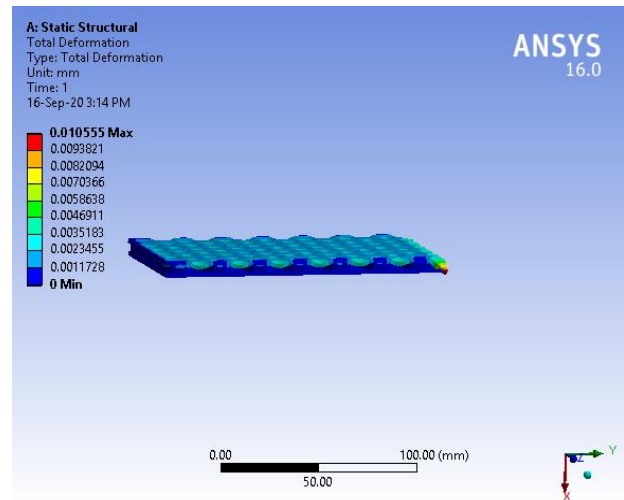

Fig 4.1.2 Total deformation of Hastelloy -X

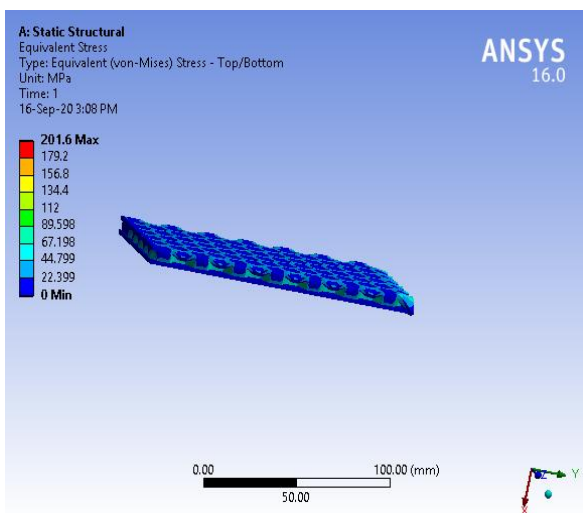

Fig 4.1.3 Von misses stress of aluminium

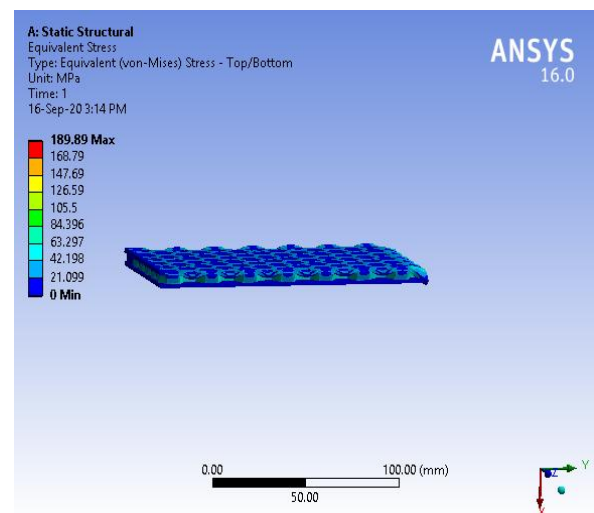

Fig 4.1.4 Von misses stress of Hastelloy X

**Results:** From the above analysis we can say that the stress that is developed in Hastelloy X is very less when compared to the aluminium. It states that the Hastelloy X absorbs less pressure which gives more life to the component.

**Table 1** Values of case – I

Case 1	Total Deformation	Von-Mises Stress
Aluminium	0.01598 mm	201.6 Mpa
Hastelloy x	0.01055 mm	189.89 Mpa

## 4.2 Case II: One End Fixed (Cantilever Beam)

In this case, we fix the one side length as a cantilever beam, and uniform load is applied on the free end. We can find the deformation and stress-induced on the beam.

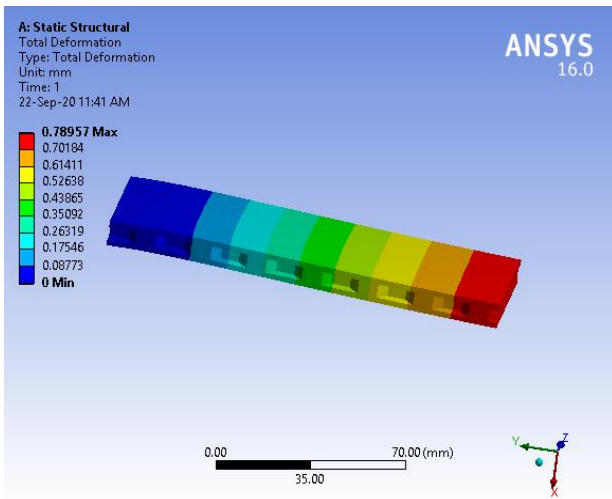
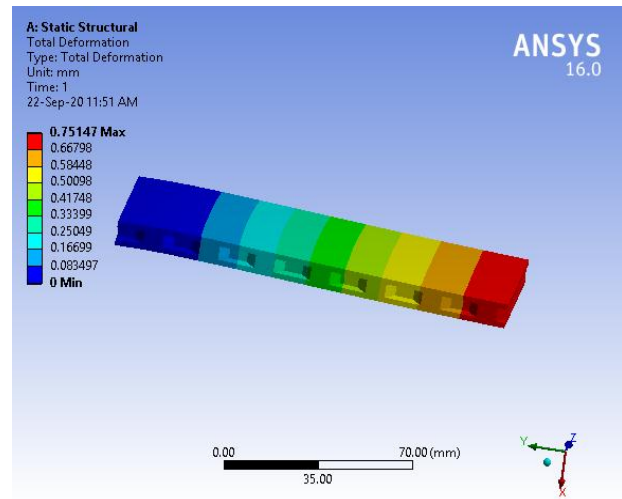

Fig 4.2.1 Total deformation of aluminium



4.2.2 Total deformation of Hastelloy -X

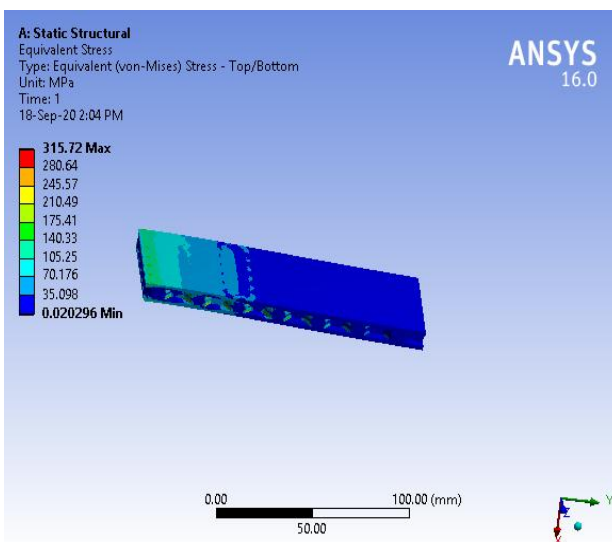

Fig 4.2.1 Von misses stress of aluminium

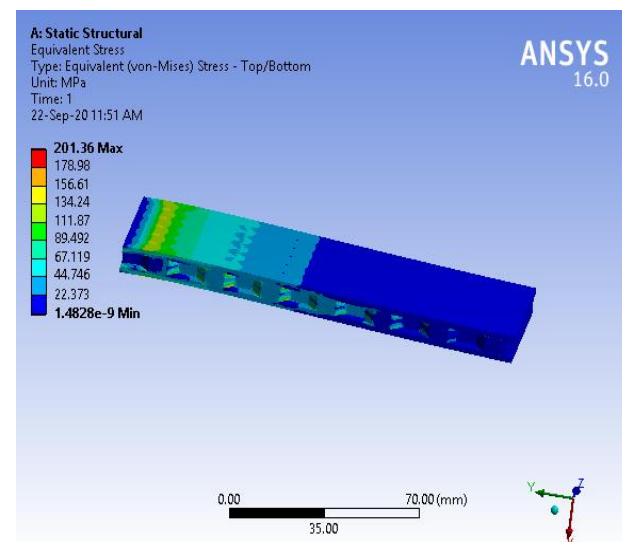

Fig 4.2.2 Von misses stress of Hastelloy X

**Results:** From the above analysis we can state that the Hastelloy -X has less deflection when compared to the aluminium.

**Table 2** Values of Case – II

Case 2	Total Deformation	Von-Mises Stress
Aluminium	0.78957 mm	315.72 mpa
Hastelloy x	0.75147 mm	201.36 mpa

### 4.3 Case III: Both the Ends Fixed

In this case, we fix both the side length of the component and subject the load at the center. Complete stress is induced at the center.

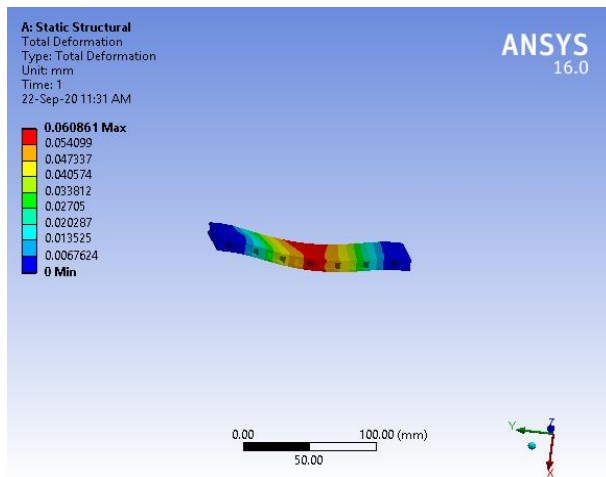

Fig 4.3.1 Total deformation of Aluminium

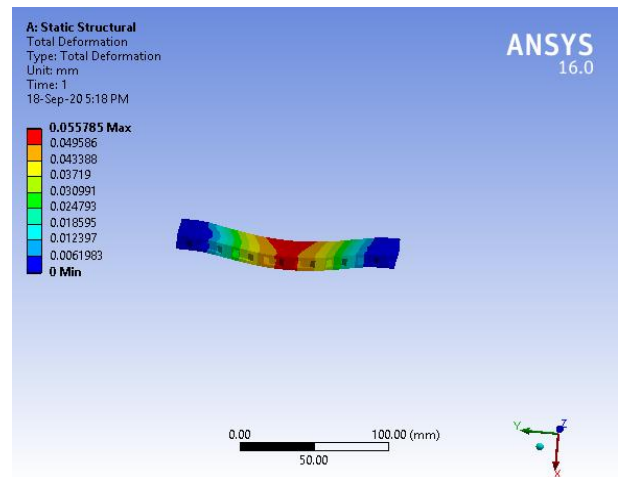

Fig 4.3.2 Total deformation of Hastelloy X

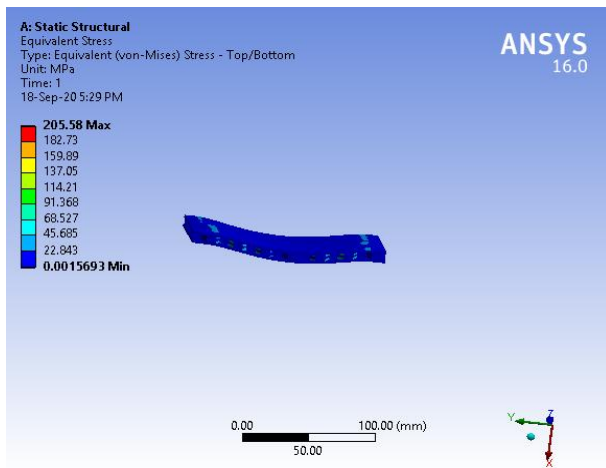

Fig 4.3.3 Von misses stress of Aluminium

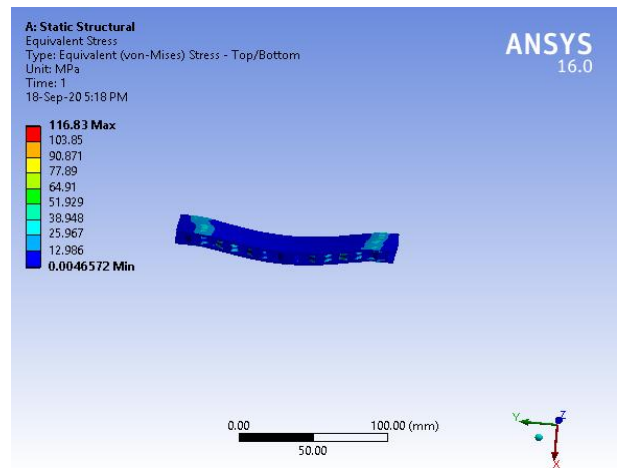

Fig 4.3.4 Von misses stress of Hastelloy X

**Results:** From the above analysis we can state that the Maximum deflection has taken place at the center of the beam and the Hastelloy X has less value compared to the Aluminium.

Table 3 Values of Case – III

Case 3	Total Deformation	Von-Mises Stress
Aluminium	0.060861 mm	205.58 mpa
Hastelloy x	0.055785 mm	116.83 mpa

### 4.4 Fatigue Analysis

The material strength cannot be decided through a single static load. Material strength will be known when it is subjected to repeated variations in the load. The Phenomenon of decreasing the strength of the material is known as fatigue. A fatigue failure begins with a small crack. To do the fatigue analysis we must take one condition from the above case and apply the fatigue analysis to it. Here we consider the first case and apply the fatigue analysis to it.

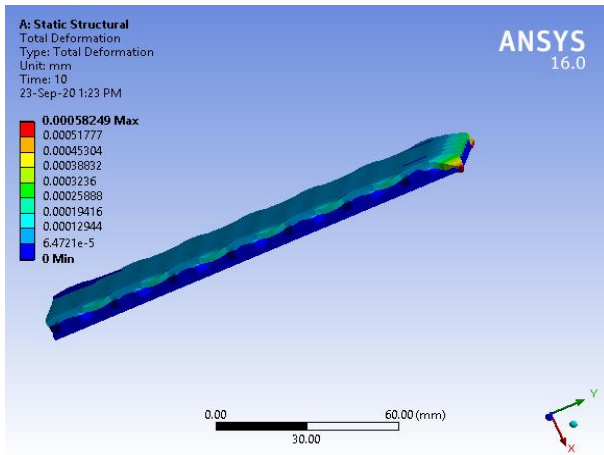

Fig 4.4.1 Total deformation of aluminium

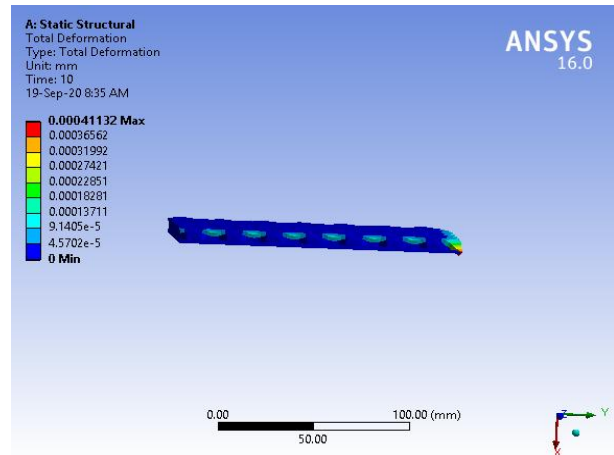

Fig 4.4.2 Total deformation of Hastelloy -X

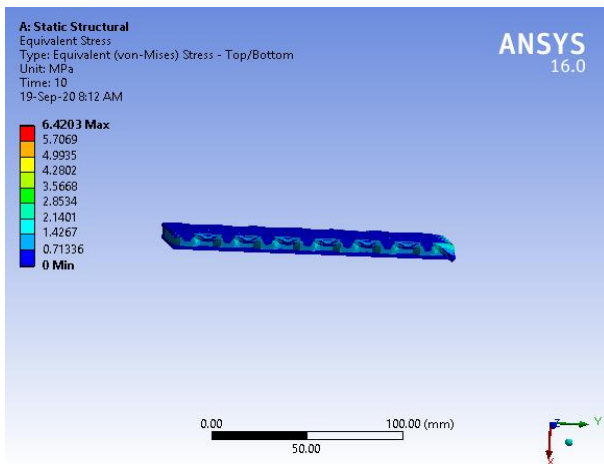

Fig 4.4.3 Von misses stress of aluminium

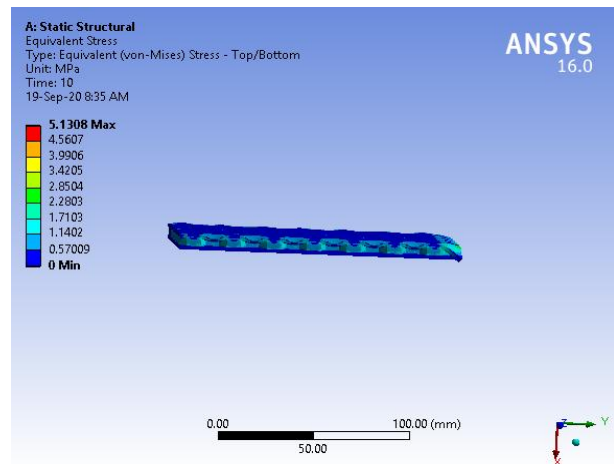

Fig 4.4.4 Von misses stress of Hastelloy X

**Results:** From the fatigue analysis we can say that Hastelloy X has more strength when compared with aluminium. Hastelloy X has survived a greater number of load cycles when compared with Aluminium. The Graph of Stress to the number of cycles for different alternating stress ratio is given below.

**Graphs for Aluminium Al3003**

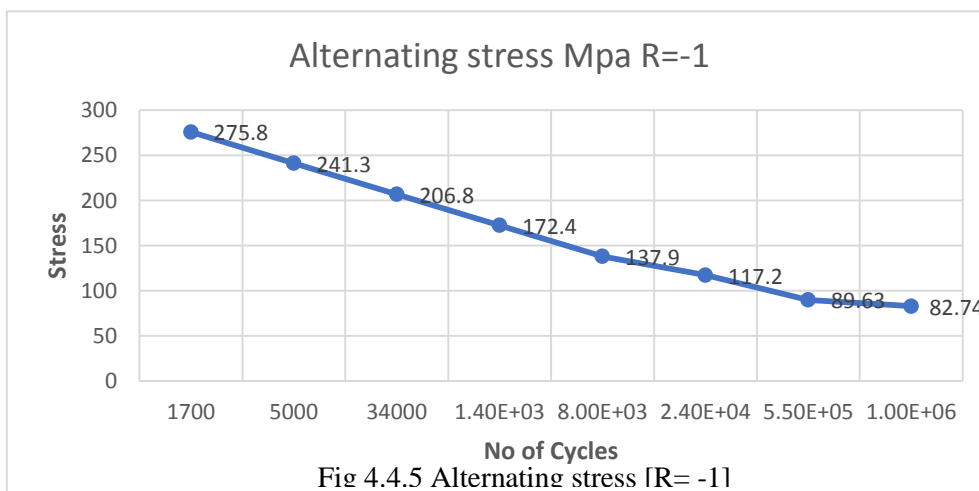
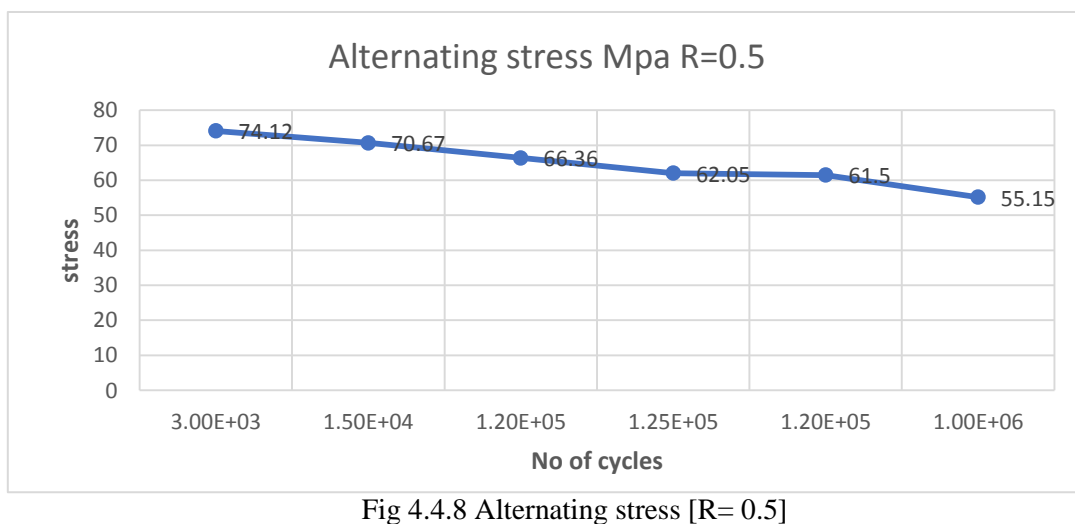
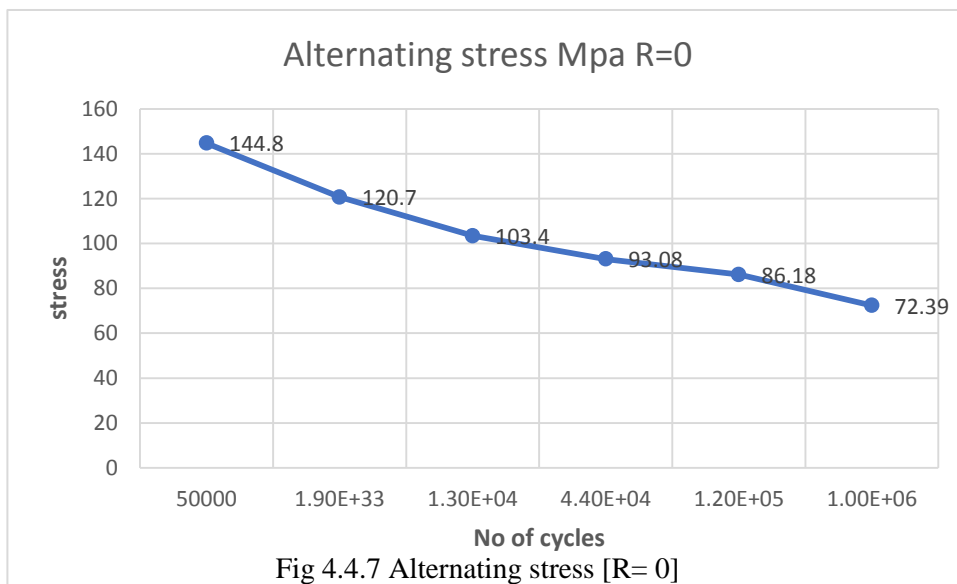
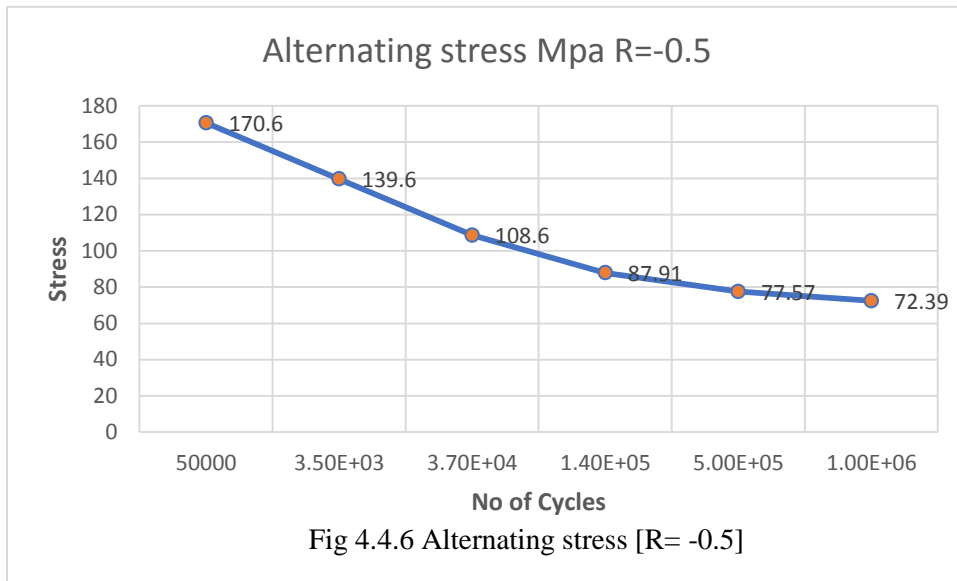
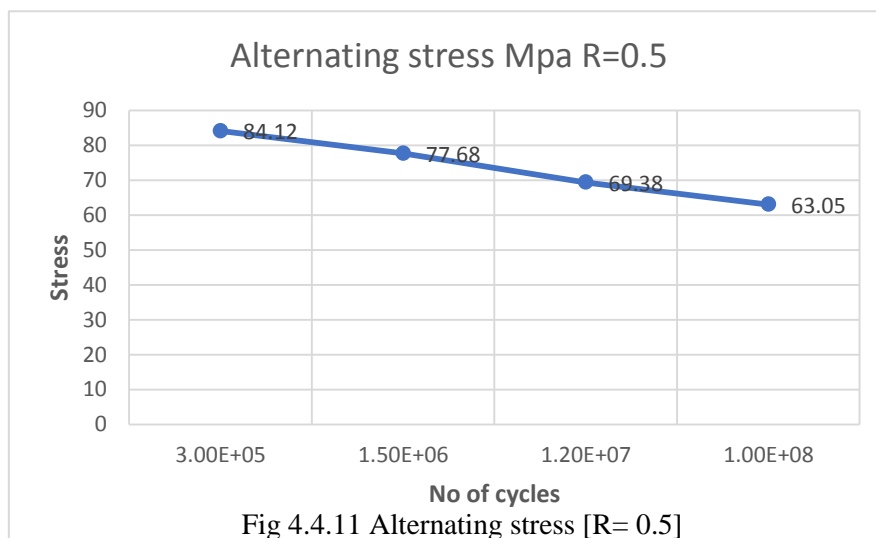
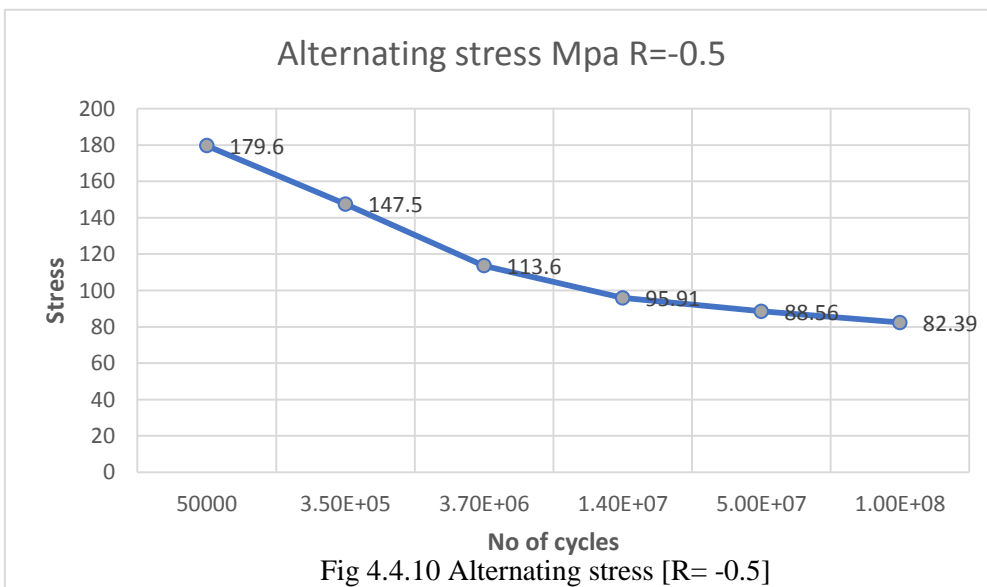
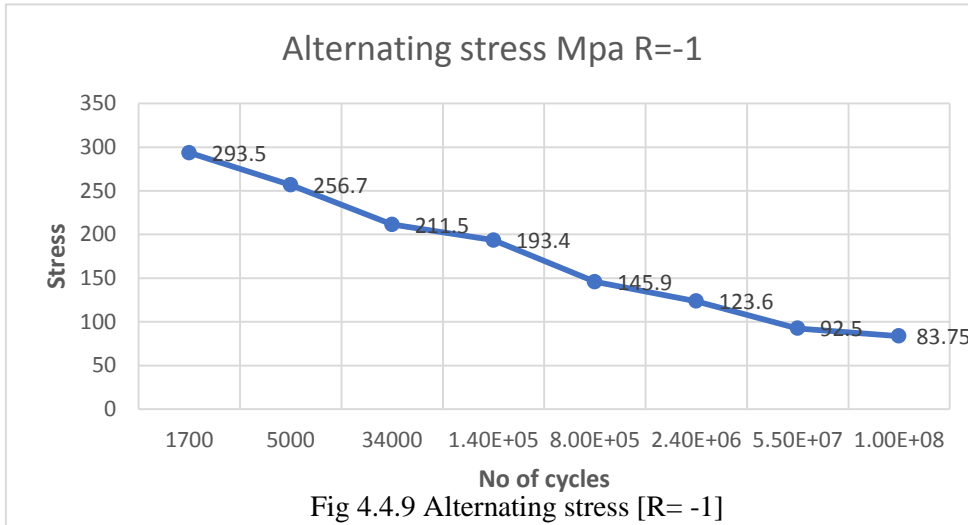

Fig 4.4.5 Alternating stress [R= -1]





Graphs for Hastelloy - X



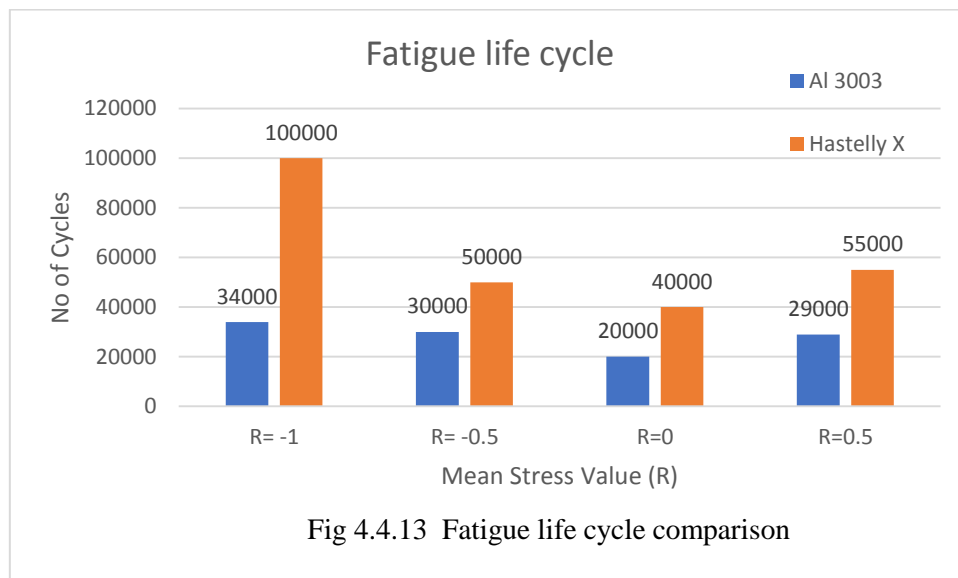
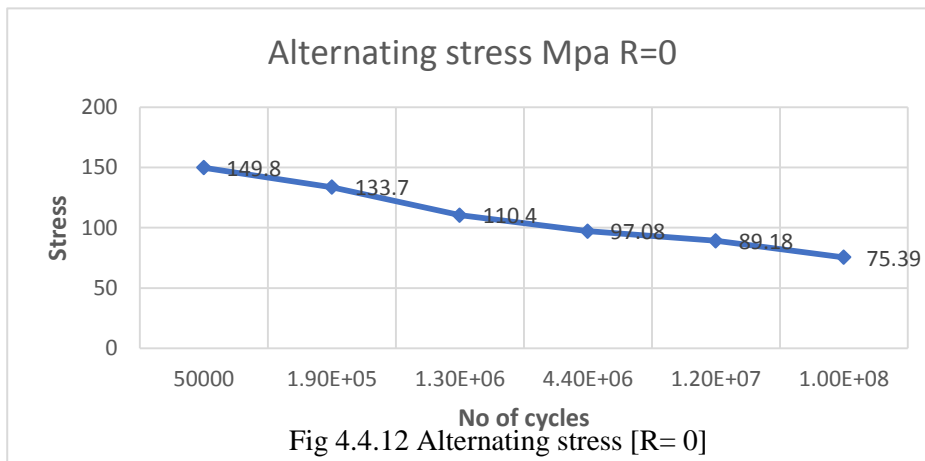

Table 4 Values of Fatigue Analysis

	AL3003	Hastelloy X
Total Deformation	0.0005823 mm	6.420 mm
Von misses stress	0.0004113 mpa	5.1308 mpa
Fatigue life	1.e+006 cycles	1.e+008 cycles
Safety factor	13.426	>15

### 4.5 Thermal Analysis

The basis for thermal analysis in ANSYS is a heat balance equation obtained from the principle of conservation of energy. The finite element solution you perform via Mechanical APDL calculates nodal temperatures, then uses the nodal temperatures to obtain other thermal quantities.

In this experiment, we did the transient thermal analysis on Al3003 and Hastelloy-X to find the heat flux that developed over a period of time.

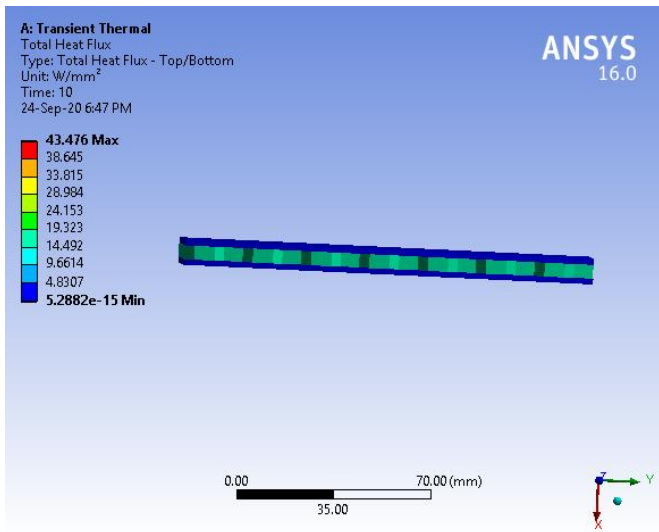

Fig 4.5.1 Heat Flux of Aluminium

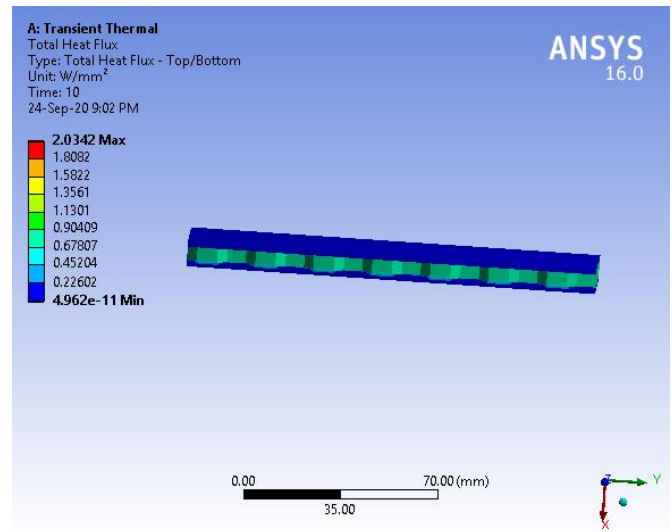

Fig 4.5.2 Heat Flux of Hastelloy X

**Results:** The heat flux induced more on the Al3003 when compared with Hastelloy X. The temperature was increased up to 500 °C and maintained a minimum of 20°C. The heat flux helps to evaluate heat transfer performance such as thermal protection, metal Heat treatment, etc. As it states clearly that aluminum has more heat absorption when compared with Hastelloy X.

**Table 5** Values of ANSYS Thermal Analysis

Anslys value	Heat Flux
Aluminum	43.47 W/mm -k °C
Hastelloy X	2.0342 W/mm -k °C

**Theoretical Analysis**

Since Heat transfer through the wall is done by conduction, the heat flux may be determined from Fourier's law. Using the equation, we have

$$Q_x = -kA \frac{\Delta T}{L} \text{----- (1)}$$

Q=Heat flow through a body per unit time

A= surface area of heat flow

ΔT = Temperature difference of the faces of a block of thickness

L=thickness of the plate

**Analysis:**

Since heat transfer through the wall is by conduction, the heat flux may be determined from Fourier's law.

Area = length x breath x Height

= 140mm x 70mm x 9mm

= 88,200 mm

**For Aluminium**

Thermal conductivity = 154 W/m-k °C

Temperature  $T_1 = 500^\circ\text{C}$

$T_2 = 22^\circ\text{C}$

Using Equation 1

$$\begin{aligned}
 Q_x &= -kA \frac{\Delta T}{L} \\
 &= -154 \times 88,200 \times ((500^\circ\text{C} - 22^\circ\text{C})/140) \\
 &= 1,35,828 \times 3.41428 \\
 &= 46.3754 \times 10^6 \text{ W/mm -k}^\circ \text{ C}
 \end{aligned}$$

**For Hastelloy X**

Thermal conductivity = 9.1 W/m-k° C

$$\begin{aligned}
 Q_x &= -9.1 \times 88,200 \times (-3.41428) \\
 &= 2.740 \times 10^6 \text{ W/mm -k}^\circ \text{ C}
 \end{aligned}$$

**Table 6** Values of Theoretical Thermal Analysis

Theoretical Value	Heat Flux
Aluminum	46.375 W/mm -k° C
Hastelloy X	2.740 W/mm - k °C

**Conclusion**

Honeycomb structure has good strength with minimum compression and minimum deformation rate. Based on the ANSYS results we can say that Hastelloy X has a good working condition at high temperatures with a low corrosive rate when compared with aluminum. Whereas aluminum has less heat flux which can not be used at high-temperature conditions. Now a day to attain high efficiency in aerospace and aircraft applications the material should resist high-temperature conditions and should have good fatigue resistance also. From the above properties, we can state that the Hastelloy x is suitable for aircraft and aerospace applications as it is strong and good heat resistance.

**References:**

[1] H. Herranen, O. Pabut, M. Eerme, J. Majak, M. Pohlak, J. Kers, M. Saarna, G. Allikos and A. Aruniit (2012), "Design and Testing of Sandwich with Different Core Material", Materials Science, vol. 18, pp 45-40, 2012.

[2] Giulia Palomba, Gabriella Epasto, Vincenzo Crupi, Eugenio Guglielmino (2018), Single and Double-Layer Honeycomb Sandwich Panels Under Impact Loading, International Journal of Impact Engineering (2018), DOI: 10.1016/j.ijimpeng.2018.07.013

[3] C. W. Schwingshackl, G.S. Agleitti, and P.R. Cunningham (2006), "Determination of Honeycomb Material Properties Existing Theories and Alternative Dynamic Approach", Journal of Aerospace Engineering, vol.19, pp 177-183, 2006.

[4] M. M. Venugopal, S.K. Maharana, and K.S Badarinarayan (2013), "Finite Element Evaluation of Composite Sandwich panel", Journal of Engineering Science and Technology Management, vol. 2, 2013.



- [5] Audibert.c, Andréani A.S, Lainé. E, Grandidier J C (2019) Discrete modeling of low-velocity impact on Nomex® honeycomb sandwich structures with CFRP skins *Composite Structures* 207 (2019) 108–118
- [6] B. Mokhtar, H. Fodil and K. Mostapha (2010), "Bending Analysis of Symmetrically Laminated Plates", *Leonardo Journal of Sciences*, vol.16, pp 105-116, 2010.
- [7] ~Banoth Ganesh, B Vijay Kumar (2015), Design and structural analysis of aircraft floor panel, *International journal of advanced engineering and global technology*, volume 03, issue 12.
- [8] Shaik.Nazeer (2015), Design and Analysis of Honey Comb Structures with Different Cases, *International Journal of Engineering Development and Research*, Volume 3, Issue 4.
- [9] Dr.Flora Jessica H.D, Dr. Lucas Patrick L. (2016), Modelling of Hexagonal Cell Structure Using ANSYS Analysis, *SSRG International Journal of Mechanical Engg*, volume 3 issue 3.
- [10] Saniman, M. N. F., M Hashim, M. H., Mohammad, K. A., Abd Wahid, K. A., Wan Muhamad, W. M., & Noor Mohamed, N. H. (2020). Tensile Characteristics of Low Density Infill Patterns for Mass Reduction of 3D Printed Polylactic Parts. *International Journal of Automotive and Mechanical Engineering*, 17(2), 7927-7934. <https://doi.org/10.15282/ijame.17.2.2020.11.0592>
- [11] Sugavaneswaran, M., Saha, S., Kumar, P. P., Sharma, G. S., & Prakash, R. (2019). Computational Fluid Analysis on Catalytic Converter with More Surface Area Monolithic Structure. *International Journal of Automotive and Mechanical Engineering*, 16(3), 7093-7107. <https://doi.org/10.15282/ijame.16.3.2019.18.0530>
- [12] Hryciów, Z., Jackowski, J., & Żmuda, M. (2020). The Influence of Non-Pneumatic Tyre Structure on its Operational Properties. *International Journal of Automotive and Mechanical Engineering*, 17(3), 8168-8178. <https://doi.org/10.15282/ijame.17.3.2020.10.0614>
- [13] W. Miller, C.W. Smith, K.E. Evans, (2011), Honeycomb cores with enhanced buckling strength, *Composite Structures*, Volume 93, Issue 3, 2011, Pages 1072-1077, ISSN 0263-8223, <https://doi.org/10.1016/j.compstruct.2010.09.021>.
- [14] Asprone, D. et al. "Statistical finite element analysis of the buckling behavior of honeycomb structures." *Composite Structures* 105 (2013): 240-255.
- [15] Mozafari H, Molatefi H, Crupi V, et al. In plane compressive response and crushing foam filled aluminum honeycombs. *J Compos Mater* 2015; 49: 3215–3228.
- [16] Crupi, V., Kara, E., Epasto, G., Guglielmino, E., & Aykul, H. (2016). Theoretical and experimental analysis for the impact response of glass fibre reinforced aluminium honeycomb sandwiches. *Journal of Sandwich Structures & Materials*, 20(1), 42–69. doi:10.1177/1099636216629375
- [17] Adams, R. D., & Maheri, M. R. (1993). The dynamic shear properties of structural honeycomb materials. *Composites Science and Technology*, 47(1), 15–23. doi:10.1016/0266-3538(93)90091-t
- [18] Rayjade GR and Seshagiri Rao (2015) GVR. Study of composite structure and bending characteristics- A review. *Int j curr eng technol* 2015;5:797-802.
- [19] Mohammed DF, Ameen HA and Mashloosh KM (2015) Experimental and numerical analysis of AA3003 honeycomb sandwich panel with different configurations, *Am J Sci Ind Res* 2015;6:25-32.
- [20] M. Yamashita, M. Gotoh, "Impact behavior of honeycomb structures with various cell specifications - numerical simulation and experiment" *International Journal of Impact Engineering*, 32,618–630.2005.
- [21] Muhammad Kashif Khan, " Mechanical Properties of Honeycomb Sandwich Panels of Aluminum and Glass Fiber Facings of Different Core Thickness from ASTM Standards", <http://www.suparco.gov.pk/downloadables/properties-honeycomb.pdf>, 2006.
- [22] Ahmed Abbadi, Y. Koutsawa, A. Carmasol, S. Belouettar, Z. Azarib, "Experimental and numerical characterization of honeycomb sandwich composite panels" , *Simulation Modelling Practice and Theory*, Volume 17, Issue 10, pages 1533–1547, November 2009.

[23] PauliusGriškevičius, DaivaZeleniakienė, VitalisLeišis , Marian Ostrowski, "Experimental And Numerical Study of Impact Energy Absorption of Safety Important Honeycomb Core Sandwich Structures", Materials Science, 16, 119- 123, 2010.

[24] K.KanthaRao, K. JayathirthaRao, A.G.Sarwade, B.MadhavaVarma, "Bending Behavior of Aluminum Honey Comb Sandwich Panels" International Journal of Engineering and Advanced Technology (IJEAT). Volume-1, Issue-4, April 2012.