

Plant Disease Detection Robot

Vignesh M¹, Yogeswaran A², Rangunath S³, Rohan babu D⁴

¹Student, Department of Electronics and Instrumentation, Bannari Amman Institute of Technology, Erode, Tamil Nadu, India..

²⁻⁴Student, Department of Electronics and Instrumentation, Kumaraguru College of Technology, Coimbatore, TamilNadu, India

Abstract - Identifying the disease is the only way to prevent the losses in the yield and quantity of the agricultural products. The plant disease means nothing about the disease which can be identified by seeing physical abnormalities of the plants (eg. Shrinking of leaves). Improper maintenance or verification of plant disease can lead to huge loss for the farmers. Health monitoring and disease detection on plants is very critical for sustainable agriculture. It is very difficult to identify the disease manually for large areas. It requires more manpower who are experts in plant diseases and it also requires more processing time. It will be the most useful thing for farmers to maintain the health of plants. Hence, image processing is used for the detection of plant diseases. Disease detection involves the steps like image acquisition, image pre-processing, image segmentation, feature extraction and classification. Our Robot has solar connectivity for power supply which will have an uninterrupted power source. The image which is captured undergoes processing as a result we receive a SMS via mobile phones. The SMS contains the detailed information about the disease as well as the solution for the disease. It will be more comfortable to maintain and protect large areas of plants and their productivity.

idea that they can con-tact to experts. Due to which consulting experts even cost high as well as time consuming too. In such conditions, the suggested technique proves to be beneficial in monitoring large fields of crops. Automatic detection of the diseases by just seeing the symptoms on the plant leaves makes it easier as well as cheaper. This also supports machine vision to provide image based automatic process control, inspection, and robot guidance.[1]

1.1 Arduino Uno



Fig -1: Arduino Uno

Key Words: Plant disease, Image processing, solar power,

1. INTRODUCTION

The agricultural land mass is more than just being a feeding sourcing in today's world. Indian economy is highly dependent of agricultural productivity. Therefore in the field of agriculture, detection of disease in plants plays an important role. To Detect a plant disease in the very initial stage, use of automatic disease detection technique is beneficial. For instance a disease named little leaf disease is a hazardous disease found in pine trees in the United States. The affected tree has a stunted growth and dies within 6 years. Its impact is found in Alabama, Georgia parts of the Southern US. In such scenarios early detection could have been fruitful.

The existing method for plant disease detection is simply naked eye observation by experts through which identification and detection of plant diseases is done. For doing so, a large team of experts as well as continuous monitoring of plants is required, which costs very high when we do with large farms. At the same time, in some countries, farmers don't have proper facilities or even the

The **Arduino Uno** is an open-source microcontroller board based on the Microchip ATmega328P microcontroller and developed by Arduino.cc. The board is equipped with sets of digital and analog input/output (I/O) pins that may be interfaced to various expansion boards (shields) and other circuits. The board has 14 digital I/O pins (six capable of PWM output), 6 analog I/O pins, and is programmable with the Arduino IDE (Integrated Development Environment), via a type B USB cable. It can be powered by the USB cable or by an external 9-volt battery, though it accepts voltages between 7 and 20 volts.

1.2 Raspberry pi 3 model B



Fig -2: Raspberri pi 3 Model B

Raspberry Pi is a series of small single-board computers developed in the United Kingdom by the Raspberry Pi Foundation in association with Broadcom. Early on, the Raspberry Pi project leaned towards the promotion of teaching basic computer science in schools and in developing countries. Later, the original model became far more popular than anticipated, selling outside its target market for uses such as robotics. It is now widely used in many areas, such as for weather monitoring, Because of its low cost, modularity, and open design.[1]

1.3 Raspberry pi camera module



Fig -3: Raspberri pi Camera Module

The **Raspberry Pi Camera Module v2** replaced the original Camera Module in April 2016. The v2 Camera Module has a Sony IMX219 8-megapixel sensor (compared to the 5-megapixel OmniVision OV5647 sensor of the original camera). It attaches via a 15cm ribbon cable to the CSI port on the **Raspberry Pi**.

2. Working

A. Input Image: The first step in the proposed approach is to capture the sample from the digital camera and extract the features. The sample is captured from the digital camera and the features are then stored in the database.

B. Image Database: The next point in the project is creation of the image database with all the images that would be used for training and testing. The construction of an image database is clearly dependent on the application. The image database in the proposed approach consists of 140 image samples. The image database itself is responsible for the better efficiency of the classifier as it is that which decides the robustness of the algorithm.

C. Image Pre-processing: Image pre-processing is the name for operations on images at the lowest level of abstraction whose aim is an improvement of the image data that suppress undesired distortions or enhances some image features important for further processing and analysis tasks. It does not increase image information content. Its methods use the considerable redundancy in images. Neighbouring pixels corresponding to one real object have the same or similar brightness value. If a distorted pixel can be picked out from the image, it can be restored as an average value of neighbouring pixels .In the proposed approach image

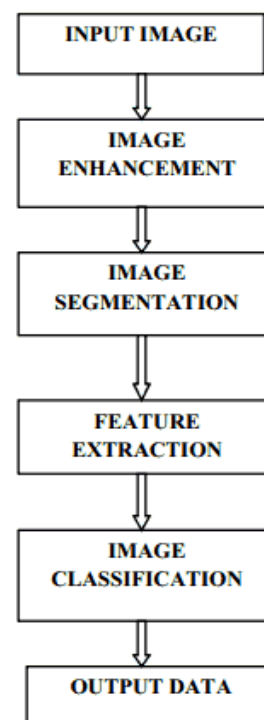

Fig -4: Block diagram of Image Processing pre-processing methods are applied to the captured image which are stored in the image database. [2]

3. Segmentation of image

Image segmentation is a process i.e. used to simplify and/or change the representation of an image into something that is more meaningful and easier to analyze. As the premise of feature extraction and pattern recognition, image segmentation is one of the fundamental approaches of digital image processing. Image Segmentation is the process that is used to distinguish objects of interest from background.[3]

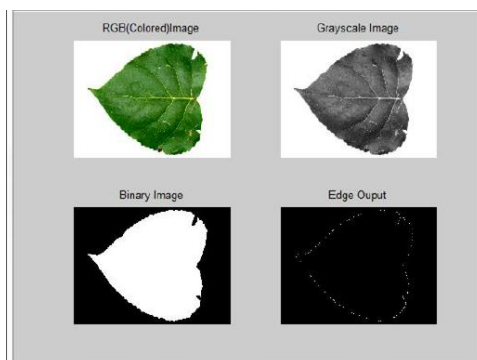

Fig -5: Segmentation of Image

4. Classification of diseased plants

For classification we used the MobileNet SSD model due to its relatively small size and the fact that it already had a method to upload to an android app. We got the data by using 5-10 second videos and created a script to extract images from these videos. The videos themselves had been placed in folders named after the disease and the plant. We made sure to take these videos under different conditions and at different locations. The total training dataset consisted of about 2000 images. We also made a website to show the output of the classification and the overall map of the greenhouse and its plant health. The website uses XML data to create this grid. We did not have time to add real time updates to the website from the classifier but it is one of our future goals. We also tested the SMS system by Twillo to send a message to a phone when the plant disease is above a given threshold. Again due to time constraints, we have not connected it to the classifier yet.

5. Circuit Diagram

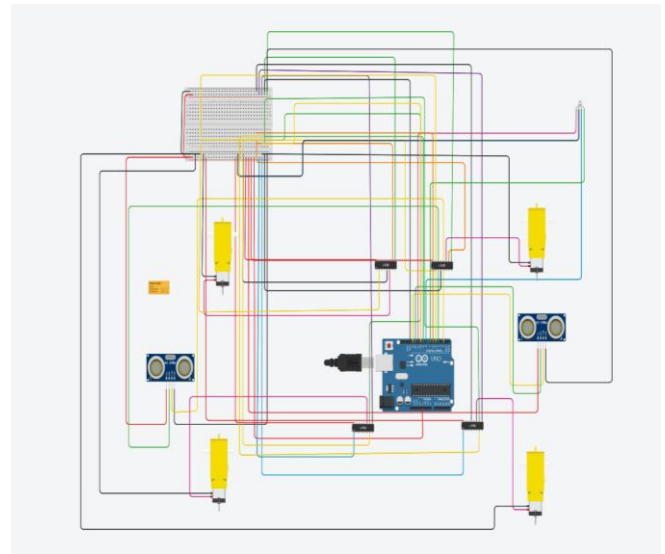

Fig -6.: Schematic Diagram

6. CONCLUSION

The accurate detection and classification of the plant disease is very important for the successful cultivation of crops and this can be done using image processing. This paper discussed various techniques to segment the disease part of the plant. This paper also discussed some Feature extraction and classification techniques to extract the features of infected leaf and the classification of plant diseases. The use of ANN methods for classification of disease in plants such as self organizing feature map, back propagation algorithm, SVMs etc. can be efficiently used. From these methods, we can accurately identify and classify various plant diseases using image processing techniques.

REFERENCES

- [1] Janwale, Asaram. (2017). Plant Leaves Image Segmentation Techniques: A Review. INTERNATIONAL JOURNAL OF COMPUTER SCIENCES AND ENGINEERING. 5. 147-150.
- [2] Sachin D. Khirade, Plant Disease Detection Using Image Processing, 2015 International Conference on Computing Communication Control and Automation
- [3] Anand. H. Kulkarni, Applying image processing technique to detect plant diseases, International Journal of Modern Engineering Research (IJMER), ISSN: 2249-6645