

Design & Development of Automatic Ground Clearance Adjustment car by using Pneumatic System

Anup Pendor¹, Vaibhav Nalawade², Abhishek Kulkarni³, Siddeshwar Parshetty⁴, Renu Shashtri⁵

¹⁻⁴Students, Department of Mechanical Engineering, MIT-Academy of Engineering, Pune, Maharashtra, India

⁵Faculty, Department of Mechanical Engineering, MIT-Academy of Engineering, Pune, Maharashtra, India

ABSTRACT - The handling of a vehicle depends upon the various parameters, centre of gravity of the vehicle is one of them. For better handling of the vehicle we need to keep the centre of gravity as low as possible. For sport cars it is always kept low but for the passenger cars it compromises with its ground clearance. The designers prefer to maintain fixed ground clearance and design the system to acquire requisite suspension parameters. For different types of tracks, the ground clearance of vehicles is designed accordingly and that is why this is a subtle reason which also differentiates the vehicles as on-road (Sedan/Hatchback cars) and off-road (Sports utility vehicles (SUV)).

1. INTRODUCTION

Road conditions are not similar at all places, it changes with application, environment and climate. In cities at different sectors like school, hospital there are speed breakers of different dimensions. At certain conditions the road goes straight without any pits else we found irregularity. Most of the people buy only one four wheeler which they use at all this condition. Hence it's necessary to give some standard ground clearance to the vehicle. But still there is some obstruction while driving the car on the highway and in the city. It is not possible for the off-road vehicle to run at high speed on its standard ground clearance provided considering the city obstacles and on-road cars to run over the rough terrain with its lower ground clearance. To obtain good performance at high speed and low speed it is necessary to build one system which can vary the ground clearance. This can be achieved by changing the suspension height so that the chassis height can be adjusted with respect to the speed and the quality of roads. Suspension systems play a vital role while designing the car for good stability and road holding ability. It is very difficult to achieve this ability at all road conditions with passive suspension systems only.

This problem can be solved "Ghanshyam Baghel, Prince Jaiswal – Adjustable Ground Clearance in Vehicles Using Pneumatic Lifting" said that the pneumatic lifting technique which is used to provide the higher ground clearance at the time of rough roads/breaker sand lower the same to get proper ground clearance to maintain the by active suspension system but this is not widely used because it requires more external energy and additional controlling system which affects the cost of the vehicle.

With a view to reduce the complexity and the cost while improving ride, handling and performance we can use the combination of active and passive suspension systems. In this paper various parameters are discussed which are related to the ground clearance and suspension system and its control. This gives the idea about the vehicle characteristics like ride control, height control, roll control, road holding etc. and its effect on vehicle performance. Ground clearance is the position of the vehicle body (sprung mass) above the basic ground level. It is an important parameter in off-road vehicles. For a certain car's weight, there is a certain amount of mechanical down force which acts on tires, and therefore the grip of tires is constantly changing during running condition. The whole weight of the vehicle is concentrated at a point known as the centre of gravity.

2. LITERATURE SURVEY

"Kumar Mayank - Adjustable Ground Clearance System by using Gear and Tooth Mechanism" said that designed a simple mechanical linkage mechanism for ground clearance adjustment. The adjustment is possible at droop conditions with the help of small gear. With the help of this system we can vary ground clearance of the vehicle up to 180mm.

Aman Sharma¹, Hina Akhtar² - In this project the chassis of vehicle is lifted by the use of hydraulic pressure. Due to this lift of chassis the ground clearance of vehicle is increased so that it is able to overcome all the obstruction during drive like speed breaker, broken roads etc. stability at high speed on smooth roads.

"M. B. Bankar – Design and development of automatic pneumatic bumper system" said that the automatic pneumatic bumper system to reduce the damage for vehicles. To achieve this system modification goal he uses an IR sensor to detect the obstacles near it.

3. SYSTEM DESIGN

The requirement of hardware and software for designing of system is as follows:-

- 4 pneumatic cylinders
- 1 compressor

- 2 ultrasonic sensors
- Steel frame(i.e chassis)
- Nut & Bolts
- Battery (12v)
- CATIA(Software)

System design in CATIA is given as follows:-

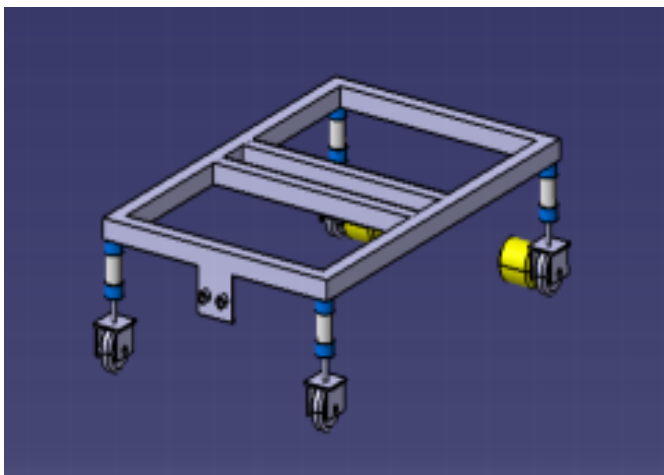
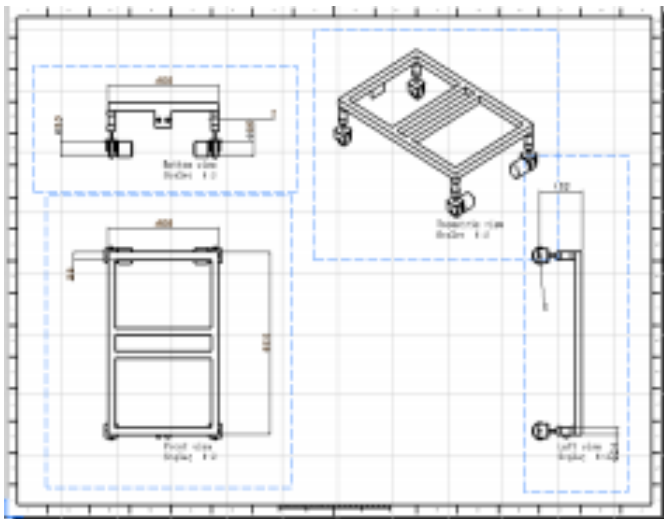

Fig -: CAD model



4. CALCULATION

Given data :

Cylinder: 20*150

Bore diameter= 20mm

Stroke length= 150mm

Volume of air exhaust =stroke *area of

piston =150*π/4*

$$=47123.889\text{mm}^3$$

$$\text{Area of piston} = \pi/4 * 20^2 = 314.15\text{mm}^2$$

$$\text{Outstroke force (F)} = \text{pressure} * \text{Area of cylinder} = 0.6 * 314.15$$

$$= 188.49 \text{ N}$$

$$\text{Piston rod area} = \pi/4 * d^2$$

$$= \pi/4 * 7^2$$

$$= 38.48\text{mm}^2$$

$$\text{Effective area} = \text{piston area} - \text{piston rod area}$$

$$= 314.15 - 38.48$$

$$= 275.66 \text{ mm}^2$$

The force applied to lift the crane in this problem is the in-stroke force.

In-stroke force for various pressures,

$$1. P = 0.4\text{Mpa}$$

$$\text{In-stroke force} = P * A$$

$$= 0.4 * 275.66$$

$$= 110.264\text{N}$$

$$2. P = 0.6\text{MPa}$$

$$\text{In-stroke force} = P * A$$

$$= 0.6 * 275.66$$

$$= 165.39\text{N}$$

$$3. P = 0.85\text{MPa}$$

$$\text{In-stroke force} = P * A$$

$$= 0.85 * 275.66$$

$$= 234.311\text{N}$$

4.1) Frame We have considered frame size as,

Length of frame=762 mm

Breadth of frame=610 mm

Now in our design as on the length part of the frame overall weight of the system is placed so the length part is considered as beam, and design is done

accordingly.

While designing the beam is considered as overhang beam as two motors are placed between the ends of beam, with uniformly distributed loading,

Hence

$$UDL=100 \text{ N/m}$$

Considering total

mass of the prototype as 10kg.

Now to calculate reactions we need to simplify the load diagram. Considering equilibrium conditions,

Now to find the reactions at A and B,

1.Moment about A is considered as 0. So,

$$R_b=37.54 \text{ N}$$

2.Forces in Y direction=0. So,

$$R_a=38.56 \text{ N}$$

Now we are doing calculations for shear force diagram,

$$SF_{cl}=0 \quad SF_{cr}=0$$

$$SF_{al}=-15.2 \text{ N} \quad SF_{ar}=23.36 \text{ N}$$

$$SF_{bl}=-22.34 \text{ N} \quad SF_{br}=15.2 \text{ N}$$

$$SF_{dl}=0 \quad SF_{dr}=0$$

Now we are doing calculations for bending moment diagram,

$$BM_c=0$$

$$BM_a=-1.15 \text{ N-m}$$

$$BM_b=0.23 \text{ N-m}$$

$$BM_d=0$$

Now we know that a point at which shear force is zero maximum bending moment occurs. X is the point at which maximum bending moment occurs.

$$BM_x=4.30 \text{ N-m} = 0.0043 \text{ N-mm}$$

Now we are using the square cross sectional pipe with thickness as 2 mm.

So according to flexure formula for bending stress,

$$(M/I)=(\sigma/Y)$$

Now we know that,

$$M=0.0043 \text{ N-mm}$$

$$Y=18.85 \text{ mm} \text{ (distance of neutral axis)}$$

By using the parallel axes theorem we can

calculate the moment of inertia (I)

$$I=I_{XX1}+I_{XX2}$$

$$I=(616.03+529.40) \times 10^3 = 86.62 \times 10^3 \text{ mm}^4$$

So from above data we can calculate,

$$(0.004)/(86.62 \times 10^3)=(\sigma/18.85)$$

$$\text{Hence } \sigma = 0.858 \text{ N/m}^2$$

This is the maximum permissible stress acting on frame.

5. METHODOLOGY

5.1) Ultrasonic sensor

Ultrasonic sensors like many others, use a single transducer to send a pulse and to receive the echo.

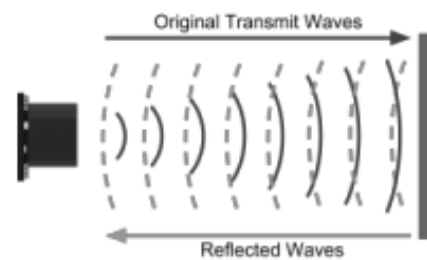

The sensor determines the distance to a target by measuring time lapses between the sending and receiving of the ultrasonic pulse.

The working principle of this module is simple. It sends an ultrasonic pulse out at 40kHz which travels through the air and if there is an obstacle or object, it will bounce back to the sensor. By calculating the travel time and the speed of sound, the distance can be calculated.

5.2) Pneumatic cylinders

Pneumatic cylinder is mechanical devices which use the power of compressed gas to produce a force in a reciprocating linear motion.

5.4) Tyre inflator



Like hydraulic cylinders, something forces a piston to move in the desired direction. The piston is a disc or cylinder, and the piston rod transfers the force it develops to the object to be moved. Engineers sometimes prefer to use pneumatics because they are quieter, cleaner, and do not require large amounts of space for fluid storage. Because the operating fluid is a gas, leakage from a pneumatic cylinder will not drip out and contaminate the surroundings, making pneumatics more desirable where cleanliness is a requirement.

5.3) Motor

A motor is an electrical machine that converts electrical energy into mechanical energy.



Most electric motors operate through the interaction between the motor's magnetic field and electric current in a wire winding to generate force in the form of rotation of a shaft. Electric motors can be powered by direct current (DC) sources, such as from batteries, motor vehicles or rectifiers, or by alternating current (AC) sources, such as a power grid, (inverters or electrical generators. An electric generator is mechanically identical to an electric motor, but operates in the reverse direction, converting mechanical energy into electrical energy.



tyre inflators are single-use devices intended to provide a quick, temporary solution to drivers who experience flat tires.

These devices seal the punctured tire and then reinflate it with pressurized gas, providing enough pressure to allow the auto to be driven for a short period at low speed. This allows the motorist to have the damaged tire professionally repaired or replaced, avoiding the need to replace the wheel at the roadside.

6. CONCLUSION

This innovation can help driver to choose the ground clearance with his comfort of driving according to terrain. Riding off-road becomes easier and the vehicle can be fuel efficient by lowering ground clearance while driving on road. For the off-road tracks, one can have higher clearance and move along the course of the road with better handling. On other hand for on road tracks, by lowering ground clearance we can enjoy the pleasure of being in an on-road vehicle. This system help in under steering of the vehicle. The system is very user friendly. This system will increase the economy of a vehicle.

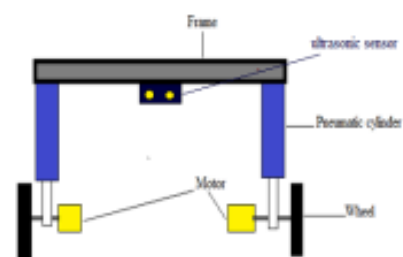

7. REFERENCES

- [1] Hrishikesh V Deo, Nam P Suh –Axiomatic Design Of Customizable Automotive Suspension|| The Third International Conference on Axiomatic Design Seoul, June 21-24, 2004
- [2] P.E. Uys, P.S. Els, M. Thoresson, –Suspension Settings for Optimal Ride Comfort Of OffRoad Vehicles Travelling On Roads with Different Roughness and Speeds|| Journal of Terramechanics 44 163– 175, 2007

[3] Debojyoti Mitra –Design Optimization of Ground Clearance of Domestic Cars|| International Journal of Engineer

[4] Cf. Fernández, C., Gavilán, M., Llorca, D. F., Parra, I., Quintero, R., Lorente, A. G., Vlacic, Lj., and Sotelo, M.A. Free Space and Speed Humps Detection using Lidar and Vision for Urban Autonomous Navigation

[5] Cf. Rudny, D. F., and Sallmann, D. W.f: Analysis of Accidents Involving Alleged Road Surface Defects (i.e., Shoulder Dropoffs, Loose Gravel, Bumps and Potholes), 1996, 6