

# WIRELESS CHARGING STATION FOR ELECTRIC VEHICLE

Darshana wagh<sup>1</sup>

\*\*\*

**Abstract** - World is shifting towards electrified mobility to reduce the pollutant emission caused by non-renewable fossil fuel vehicles. So electric vehicle came into existence. In electric vehicle charging of battery through charger and wire is expensive, hazardous and inconvenient and drawback of wire charging technology is waiting at charging stations for hours.

So now wireless charging gives us opportunity to charge our vehicle just by parking the vehicle on parking spot or even while driving we can charge our electric vehicle. As if now we are very much familiar with wireless transmission of data, audio and video signals than why not transfer power over the air. The main feature of wireless charging is that it can transmit power by an electromagnetic field. This will increase the use of electric vehicles and also make them reliable and efficient for large distance respectively. Wireless power transfer can be implemented as a static and dynamic charging system. This paper presents how the electric vehicle and development of charging methods.

**Key Words:** Wireless Power Transfer [WPT], Wireless Charging Systems [WCS], Wireless Electric Vehicle Charging System [WEVCS], Static Wireless Charging System [SWCS], Dynamic Wireless Charging System [DWCS].

## 1. INTRODUCTION:

Wireless electric vehicle charging system (WEVCS) technology operates on the principles of *magnetic inductance* and *magnetic resonance*. Wireless charging systems have been mostly used in high power applications, including EV's and plug-in electric vehicles. Comparing plug-in electric vehicles with wireless charging, WCS brings more advantage in simplicity, reliability, and user friendliness. The only problem with WCS is that they can be utilized when the car is parked or in stationery modes and also there are some challenges, such as Electromagnetic compatibility issues for example, limited power transfer, bulky structure, shorter range and high efficiency. To improve these two areas i.e. Range and sufficient volume of battery storage, dynamic mode of operations has been researched.

Dynamic charging systems are more time efficient, reliable and user friendly. This charging system can also be implemented in the travel routes, traffic signals and bus stations.

### 1.1 BASIC OPERATING PRINCIPLE:

Wireless charging is same as transformer working principle. In wireless charging there are transmitter coil and receiver coil. 220V 50HZ alternating supply supplied from the grid is converted into high frequency alternating current through

AC/DC and DC/AC converters and it is then supplied to the transmitter coil. It creates alternating magnetic flux that cuts the receiver coil and causes the assembly of AC power output in receiver coil.

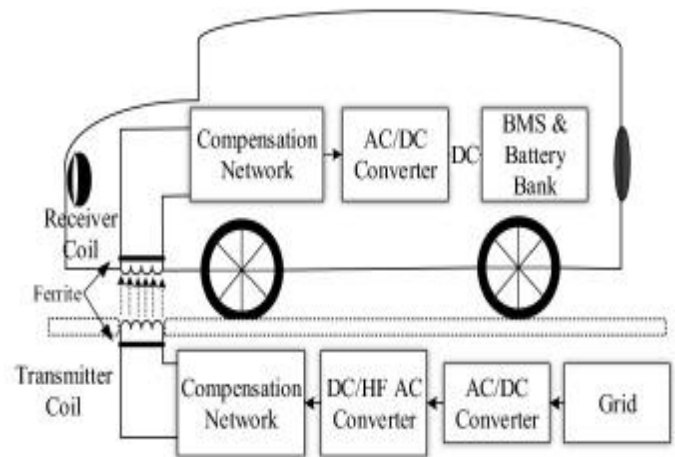

The most important thing for efficient wireless charging is to maintain the resonance frequency between transmitter coil and receiver coil so to maintain this resonant frequency compensation networks are added on both the sides. This AC power at receiver side rectified to DC through AC/DC converter and fed to the battery through Battery Management System (BMS) or Battery bank.

## 2. IMPLEMENTATION OF WIRELESS CHARGING: -

Wireless charging is used to eliminate the need of conductive wires and thus conduction losses which take place through wire can be completely cut out. The human handling of wire while charging process for plug in and plug out can sometime be dangerous if not done correctly. Though wireless charging is also time saving and effective, it comes with certain limitations. After plug in charging station, first wireless technology developed was stationery, system that is been designed to charge EV's in parking lot or garages when the vehicle is not operated for extended period. There has been major interest in the possibility of charging EVs when they are in transit. When we charge an electric vehicle while in motion is called dynamic wireless charging.

WEVCS can be distinguished in 2 categories: -

- a) STATIC WIRELESS CHARGING SYSTEM.
- b) DYNAMIC WIRELESS CHARGING SYSTEM.

### 2.1 STATIC WIRELESS ELECTRIC VEHICLE CHARGING SYSTEM: -

As the name indicates, vehicle gets charged when it is static position and can easily replace the plug-in charger with minimal driver participation. So, we could simply park the vehicle and charge its battery which is incorporated with wireless charging system.



Transmitter is fitted underneath the ground and receiver is arranged underneath the vehicles. In order to charge the vehicle, we need to align the transmitter with receiver and leave it for charging. The charging time depend on the distance between transmitter and the receiver, pad sizes, source power level. This SWCS is best to build in areas where vehicle is been parked for a certain time interval. The average distance between lightweight duty vehicles is approximately 150-300 mm. SWCS can be installed in parking areas, commercial buildings, homes, shopping centers, car parks etc.

### 2.2 DYNAMIC WIRELESS CHARGING SYSTEM [DWCS]: -

Dynamic wireless charging system is the holy grail for electric vehicle technology; as it gets charged while it is motion. It is gaining more ground in the wireless charging technology. The main concern for deployment of electric vehicle is the power and range. To improve the range of the vehicle, dynamic wireless charging would be beneficial and it can also be improved with the continuous charging of its battery while driving on the roadways and highways. It also reduces the need for large energy storage and further reduces the weight of the vehicle. The transfer of power is through the air from a stationery transmitter to the receiver coil.

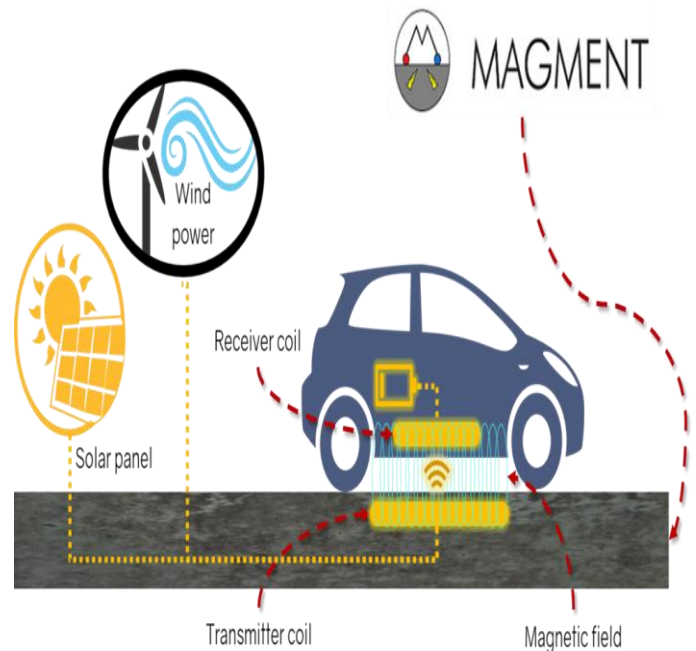

Types of wireless power transfer can be classified in 4 types: -

- Capacitive Wireless Power Transfer [CWPT]
- Permanent Magnetic Gear Wireless Power Transfer [PMWPT]
- Inductive Wireless Power Transfer [IWPT]
- Resonant Inductive Wireless Power Transfer [RIWPT]

### 3. ADVANTAGES AND DISADVANTAGES: -

Advantages: -

- Environmentally Friendly
- 80% operating cost is reduced than equivalent gas-powered vehicle.
- No fuel and No gas cost
- Maintenance cost is less than gas powered vehicle.
- Pollution Free
- Vehicles are light weight
- Electrically Safe
- Charging is convenient
- Unlimited range and Zero charging time.
- Numerous EV's can be charged at a time

- Quieter in nature than conventional vehicles

Disadvantages: -

- Lack of power and range
- Expensive
- Lack of charging stations
- Minimal amount of pollution
- Installation cost at initial time is very high
- EV's can run out of charge because of power outage
- Design is complex
- Heat generation is more than traditional charging

**Challenges faced by WEVCS: -**

- a. To install static and dynamic charging system we need to develop new infrastructure as current arrangement are not suitable for the arrangements.
- b. Need to maintain the EMC, EMI and frequencies as per the standards only for human health and safety.
- c. The most common drawback of all WPT systems is that low efficient energy is been transferred, so most of the losses take place while transfer of energy from transmitter coil to receiver coil.

**FUTURE SCOPE: -**

The future is electric and cities and nations must be prepared to keep it charged. It is based on the police that is guided and technology that spring up. Electric vehicle has the potential to revolutionize road transportation by their high performance, safe and cost-effective dynamic electric vehicle. The dynamic electric vehicle charging is foundational – this technology can also enable wirelessly powered biomedical implants, supersonic hyperloop transport and humanoid robots. The technological challenges are very exciting and have endless possibilities. Nowadays the EV's inventories are expanding immensely. As more technologies are arising materials and theories could make WEVC even more competitive. Advanced materials can also benefit power electronic devices as well. One more thing beside flux leakage, switching loss is also one of the major sources of energy waste in a WEVC system. After dispensing the manual operations, static WEVC can liberate operators but fails to make the charging system more flexible.

**CONCLUSION: -**

This paper presented review on wireless charging system for electric vehicle. Wireless charging is most efficient method for electric vehicle. Wireless charging provides numerous

benefits as compared to wired charging. As it has wide range for travelling. It reduces the time spent on recharging the vehicle and even allows the EV's to be charged during its movement. Initially it has high cost but eventually the maintenance cost gets low. It has been more prominently used because it is better than conventional wired system. By using WCEV energy crisis can be decreased and it has low power loss. According to future scenario the world is going to be completely wireless. Wireless charging provides numerous benefits as compared to wired charging. With further technological development wireless charging of EV can be brought to fruition. In further studies, inverter design control, topology and human safety are still needed in the further near term.

**REFERENCE: -**

1. Elena Paul, Nimmy Paulson, Rijo Bijoy, Benny K.K, "WIRELESS CHARGING OF ELECTRIC VEHICLES", International Research Journal of Engineering Technology, Vol.6, Issue 6, June 2019.
2. Asst Prof.Swapna Manurkar, Harshada Satre, Bhagyashree Kolekar, Pradnya Patil, Samidha Bailmare, "WIRELESS CHARGING OF ELECTRIC VEHICLE", International Research Journal of Engineering Technology, Vol.7, Issue 03, March 2020.
3. Review of static and dynamic wireless electric vehicle charging system, Chirag Panchal, Sascha Stegen, Junwei Lu "Engineering Science and Technology, Vol. 21, Issue 5, October 2018.
4. kiranmai Momidi, "Wireless Electric Vehicle Charging System [WEVCS]. July 12 2019.
5. P. Magudeswaran, G. Pradheeba, S. Priyadharshini, M. Sherline Flora, "Dynamic Wireless Electric Vehicle Charging System", International Research Journal of Engineering Technology, Vol.06, Issue 03, March 2019.