

Static Voltage Stabilizer using IGBT and PWM with DSPIC33F Controllers

Priya Suresh(PG STUDENT)¹, Rajesh Uppara (M.E)², Madhusudhan³

¹M.Tech(Power Electronics) Department of EEE SIT Tumakuru-572103

²Assistant Professor Department of EEE, SIT Tumakuru-572103

³Director ATDC Technologies Limited, Tumakuru-572103

Abstract- A good electrical power system ensures the availability of electrical power without any of the interruption to every load connected to it. Generally the power is transmitted through the high voltage transmission lines and the lines which are exposed, causes the chances of their breakdown due to storms damaging of any external objects and also damage to the insulators. Servo Voltage Stabilizer which is an electronic device that stabilizes the voltage from fickle to a desired value ranges and results in steady secure power supply to the equipment and constant output voltage. The above paper deals with the Static based voltage stabilizer type of the system controlled by a DSPIC based controller and a voltage changes are also with the transformer which is Buck-Boosttype.

Index Terms- ADC, CLA, Piccolo F28069, IGBT Drivers, SVS.

I. INTRODUCTION

The static voltage stabilizers are the devices which maintains the constant output voltage which is an SMPS type of stabilizer for the mains voltage that is AC input voltage and the AC output voltage. These are the types electronic devices which are responsible for correcting its voltage of the electrical power supply to provide the stable voltage and secured power supply to the equipment allowing for the stable voltage and protecting the equipment from problems of the mains voltage. Static voltage stabilizers are the type of devices which does not include any of the motor controlled parts as in case of the servo controlled voltage stabilizer system. Here the voltage produced to achieve the correction in voltage and time. Therefore the stabilizer is having extremely high voltage with its high primary to secondary ratio for the voltage correction speed than the servo based voltage stabilizer system. Here the function of static stabilizer is that maintaining constant output voltages, and protecting the equipments from the damage connected to its ideal electrical power supply system ensuring Oscillations in electrical power supply are offset and its output voltage maintains a stable value. The function of the static stabilizer system to improve dynamic performances of various power systems and here the simulation by using matlab studies for its performance of overall system shows that it is adaptive considering good performance conditions having wide range. This voltage stabilizers are categorized as DC voltage stabilizer, AC voltage stabilizers. Here the stable

there by avoiding damage. The disparity in its DC type of the applications and voltage stabilizer on the other side and that stabilizes the AC voltage which is actually fluctuating. The basic study of SVS is with Buck-Boost transformer with its high primary to secondary ratio for the voltage correction. As in Uninterruptable power supply commonly called as UPS type voltage stabilizer provides protection to the protection of electronic equipment. Here all the electrical or electronic equipment are designed and also manufactured to operate at its maximum efficiency with its typical voltage supply system, designed for its operating range limit which is having code-efficient assembly, ADC and S/H.

II. BLOCK DIAGRAM OF STABILIZER

When an un stabilized input voltage is given to the controller which produces a stable output voltage which is precisely constant with no voltage fluctuations. A static system plays an important function as the stability configuration for the voltage fluctuations involved and the disturbances which are transient in the nature present in the interconnected supply systems. The introduction of an adaptive controlled stabilizer loop system present for the controller improves the total power system stabilizer performances operating under the undesirable or the abnormal situations like three phase short circuit systems. In high power applications static systems there will be reduction of voltage fluctuations caused by the loads.

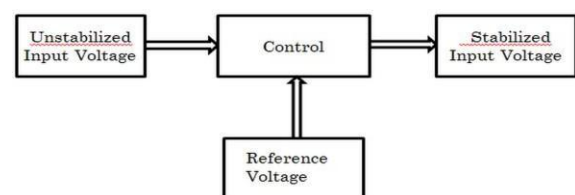

Fig.1 Block Diagram of Stabilizer

continuous supply of the AC power involving electronic system in which the over voltage shortens the life of stabilizer and under voltage reduces efficiency.

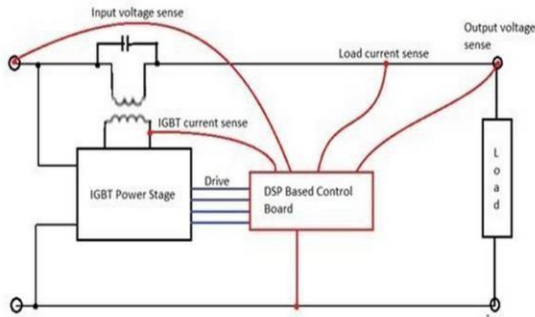

Fig.2 Circuit Diagram of Static voltage stabilizer

The Static stabilizers functions effectively which involves the property of its dynamic linearizability having algorithms, control laws which is having the ability to have constant output voltage tracking with its arbitrary range of speed convergences having the protection from the various common mode type of the noises and high momentary capacity for demanding applications and the equipments involved are control PCB, IGBT type of the power stages, AC input and the AC output which neutralises the common. The PWM control which is used in the constant torque conditions. Servo stabilizers involves microcontroller based type circuitry.

III. OBJECTIVE

The main aim of the Static Voltage Stabilizer is to provide the constant voltage supply without any variations of the system. To design a static voltage stabilizer system which is having the following features they are DSP based single card technology, Compact size when compared to the conventional type of the stabilizers, IGBT pulse width modulation AC to AC switching control, Individual phase control, Negligible output waveform distortion, Reliable and no maintenance is required,

IV. MOTIVATION

Electrical equipment can be used every where, here it can be seen in houses, offices, industries and almost all the places. The dependency of the various electrical equipment has become indispensable and the reliability of these electrical equipment is highly desirable. The failure of these electrical equipment results in heavy losses of devices and the hardships. The static voltage stabilizers which does not include any of the moving parts as in case of servo based voltage stabilizers and it is easier to produce the better accuracy and the voltage regulation systems.

V. PROBLEM STATEMENT

The quality of the electrical power supplied by electricity boards will not be good. Voltage of the supplied electrical power may deviate from the desired safe range. Many electrical equipment are sensitive on the electric voltage. The drop in voltage may be due to the overloaded conditions. There could be spike in the supply due to rain, falling of trees on electric lines or

due to the loose connection in the power line.

VI. SOLUTION

To protect the electrical equipment from mains voltage variations, the Static voltage stabilizers are used. These stabilizers are used at the input of the equipment, they will stabilize the mains voltage and will correct the abnormal voltages to a safe range. Amount of static voltage stabilization depends on the type of stabilizers which are used. The selection of the various stabilizers mainly depends on the electrical load and the cost of the stabilizers.

VII. SERVO VOLTAGE STABILIZERS

The servo controlled stabilizers are popularly called as the motor controlled type of the stabilizers which is controlled by the stabilization systems which involves the transformer which is Buck-Boost type, which captures the fluctuations caused by the voltage from its input voltages and it regulates the current to correct its output voltage. This type of stabilizer adjusts itself in the anti clockwise or the clockwise directions and manages its output voltage with the control card, comparator and dimmer.

The Optional features that the Servo Voltage stabilizer involves main circuit breakers for the overload and the short circuit protection schemes. The neutral loss is the output cut-off if neutral is missing at the input, there will be prevention of the phase loss conditions that occur in the stabilizer, it provides the electronic Overload protection, it also helps in ground fault monitoring with the trip and leakage current. It acts like a surge suppressor and also the Surge Protective device.

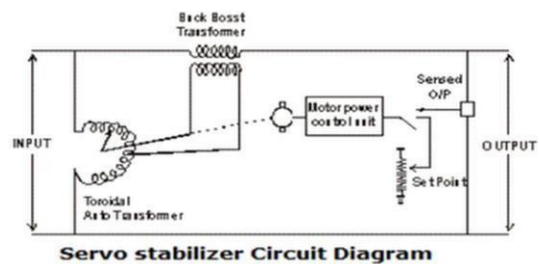

Fig.3 Servo controlled voltage stabilizer

The Servo controlled voltage stabilizer system having the moving parts provides the continuous supply of power, to regulate the supply voltage to the load. It is very common to have servo stabilizer with the refrigerators, television and the furnace equipment. Here the electrical appliance is designed to operate under the specific voltage conditions to give the desired performances. It operates the load or the system in the acceptable range of voltage, the internal circuit of a Servo voltage stabilizer consists of

autotransformer or the transformer, rectifier units, comparators, relays and switching circuits.



Fig.4 Internal circuit of Servo Voltage Stabilizer

The Voltage fluctuations depicts the change in the magnitude of the supply voltage, normally exceeding or below steady state voltage, here the electrical power distribution is 230 volts for single phase, designed to be operated in the voltage range of operation 220 volts to 240 volts. Many electrical appliance can withstand this voltage fluctuation.

By using Servo based Voltage stabilizer system. This type of stabilizer system can be used for the balanced or for the unbalanced input type of the voltages. Here the Servo stabilizers having five major components they are

1. Microcontroller used for the voltage monitoring.
2. Motorized voltage variable auto transformer.
3. The Driver unit system.
4. Double wounded Series transformer or the Buck-Boost type of the transformers.
5. Servo controlled based Sensing card also called as the Printed Circuit Boards.

These are the components for the Servo based Voltage stabilizer system, the cascaded type of the DC-DC converters application are used in servo stabilizers and in the distributed power systems. The cascaded DC-DC converters are widely used, which are tightly regulated and it operates as constant power load system known as CPL System. Composed of various components. In this type of voltage stabilizers the most of the electric hardware equipment requires a constant voltage supply and runs proficiently. The developing utilization of the various electrical and electronic equipment requires closed steady voltage supply conditions for the effective operation.

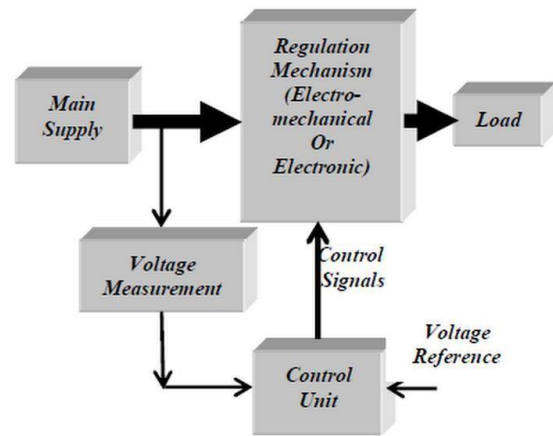
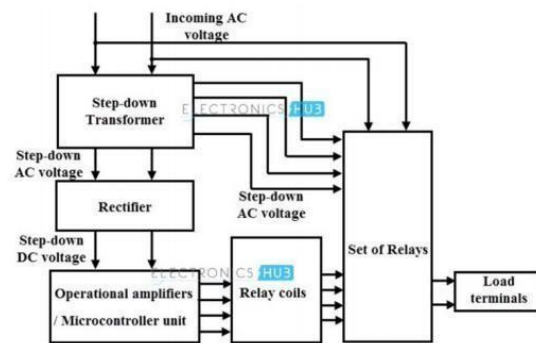

Fig.5 General concept of Servo Voltage Stabilizer

Servo Voltage stabilizer V/S Static stabilizer

| Specifications | Static Voltage Stabilizer | Servo Voltage Stabilizer |
|------------------|---------------------------|----------------------------|
| EMI Filter | No extra cost | Optional at its extra cost |
| Weight | Low weight | High Weight |
| Distortion | No Distortion | Distortion occurs |
| Overload cut off | Standard | It is Optional |
| Distortion | No Distortion | Distortion occurs |
| Noise | Silent | High Sound |
| Size | Very compact | Compact |

TYPES OF VOLTAGE STABILIZERS



Here the figure above shows the Servo voltage stabilizer system. It consists of the op-amps and here the set of relays is given to the load terminals.

VARIOUS FACTORS PLAYS IMPORTANT ROLE IN SELECTING A STATIC VOLTAGE

1. Speed-Based Stabilizer.
2. The power Based
3. Frequency based

WORKING PRINCIPLE OF SERVO BASED VOLTAGE STABILIZER SYSTEM

Voltage stabilizer system, in that the Voltage correction is from the under voltage and the over voltage conditions by the two essential operations namely Buck and Boost Operations. These operations are carried out manually by the switches or automatically through the electronic circuitry.

During under voltage conditions boost operation increases the voltage to a desired value while the buck operation reduces the voltage level during over voltage condition. The concept of stabilization involves two stages adding or subtracting the voltage to and from the mains. The figure below shows the working model of a voltage stabilizer that contains a step-down transformer, usually provided with the taps on the secondary windings, a rectifier unit, operational amplifier microcontroller units and also the set of relays.

TYPES OF SERVO VOLTAGE STABILIZERS.

1. Single-Phase air cooled servo voltage stabilizers
2. Servo controlled voltage stabilizer three phase oil cooled.

STABILIZERS

1. Wattage requirement of the appliance (or a group of appliances)
2. Type of Appliance
3. Voltage fluctuation level in area.
4. Type of Voltage Stabilizers.
5. Working range of stabilizers which we need.
6. Over Voltage/Under voltage cut off.
7. Type of stabilization/control circuit.
8. Type of monitoring for voltage stabilizers.

FUNCTIONALITIES:

1. The static stabilizers they accepts the wide range of its input voltage while maintaining the tight voltage regulation.

2. Here the IGBT modules which are involved having the function which isolates even most of the sensitive equipment from the various sags, transients and the harmonics.

3. High momentary overload capacity for demanding applications.

VIII. A Static Voltage Stabilizer

The voltage stabilizer we are using is of static offers improvements on slow Servo controlled type of voltage stabilizers. Here the basic study of the static voltage stabilizer involves the transformer which is buck-boost type, having its primary to secondary ratios for the voltage correction. The regulation of this type of voltage with the buck and boost which is attained electronically without any step changes in its voltage at the time of its system regulation. The type of system may uses various AC-AC converter circuit, power switching devices. The enhanced pulse width modulation that is control operation to achieve the desired correction time, in which the overall response of the system and involves rapid correction speed of voltage.

There are two modes of operation which in which the Static Voltage stabilizers works they are:

1. Buck mode: Output voltage is more than its desired voltage V_s which works in the buck mode here the phase and neutral switches are reversed. In the Buck mode I2 is switched using PWM and I1 is permanently switched on results in the primary voltage which is 180 degrees out of phase.

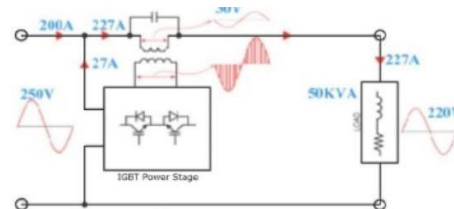

Fig.6 shows Buck mode.

2. Boost mode : The Boost mode involves IGBT module I1 is switched using PWM and the IGBT module I2 is permanently switched on. Results in generating primary voltage which is in phase with the primary voltage. Here the output voltage is always less than its desired voltage V_s works in the Boost mode of operation.

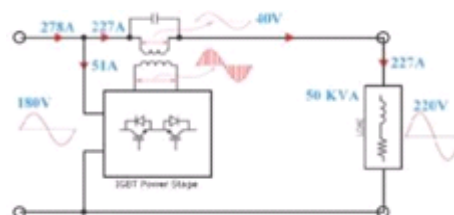

Fig.7 Boost mode of operation

Working and Analysis of SVS

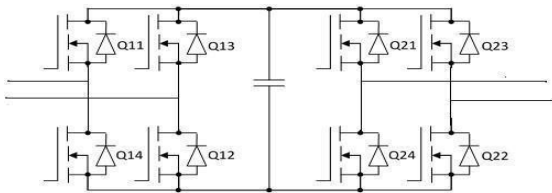

Fig.8 Circuit diagram of Single phase SVS.

$V_{out} = V_{in} + [V_{ind}(1 - d)V_{in}]n = V_{in}[1 + (2d-1)n]$, Here V_{out} which represents the output voltage and is obtained by summing the transformer type of the voltage it can be called as the Chopped type of AC voltage and also the input voltage which is V_{in} , the equation for the above expressions given by $[=n(2d-1)V_{in}]$. Here the d represents duty cycle of a stabilizer, n which is the transformer ratio. For the switching frequency it is large compared to the line frequency,

$$I_{AV-Q21} = (1/2\pi) \int d I_p \sin \omega t d\omega t + (1-d) I_p \sin \omega t d\omega t = (I_p/2\pi) \{1 - \cos \phi + 2d \cos \phi\}$$

$$I_{RMS-Q21}^2 = (1/2\pi) \int_0^{2\pi} \{d^2 \sin^2 \omega t + (1-d)^2 \sin^2 \omega t + 2d(1-d) \sin \omega t \cos \omega t\} d\omega t = (I_p^2/4\pi) \{d^2\pi + (1-2d)[\phi + \sin(2\phi)/2]\}$$

From above expressions the solution becomes, $I_{AV-D21} = (I_p/4) - I_{AV-Q21}$

$$I_{RMS-D21} = I_p/4 - I_{RMS-Q21}$$

PWM GENERATION

The Pulse width modulated signals are generated by using this type of the application and a continuous count mode of operation which is used to generate the PWM signal can be of asynchronous in the nature.

$$TBPRD = PWM \text{ Period} / 2 * TBCLK \text{ Where,}$$

$$TBCLK = SYSCLOCKOUT = 11.1ns$$

IX. PCB DESIGN SCHEMATIC

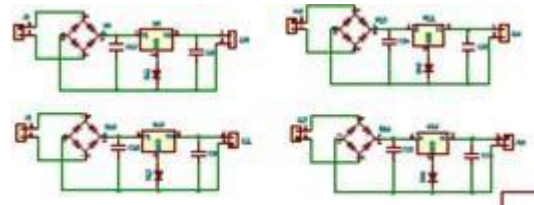
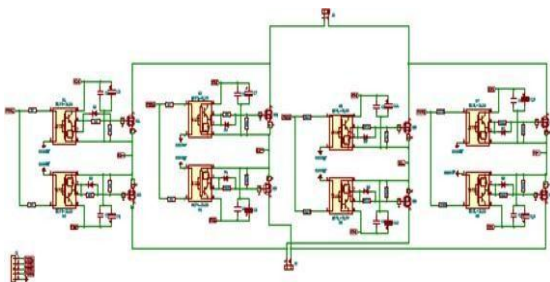

XI. HARDWARE ARRANGEMENT



Fig.9 Simulink Hardware arrangement

EXPLANATION: IGBT it can be used to switch the AC voltage. The fast recovery diodes are used in order to reduce the noises. In HCPL driver circuit opto coupler is also inserted heat sinks are also used in order to absorb the heat produced. To drive IGBT switch we are using HCPL driver IC & HCPL driver IC is controlled through PWM of DSPIC. The hardware kit which is implemented illustrates and explains about the Digital signal processing i.e DSP based controlled KVA type of the static stabilizer system which is single phase type. Here the research carried by using different components like IGBT driver circuits, buck-boost transformers , piccolo F28069 DSP kit. The hardware of this stabilizer can be arranged into the power circuit and Control circuits.

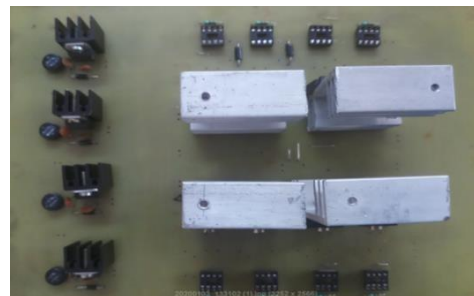

Fig.10 Circuit Board for SVS

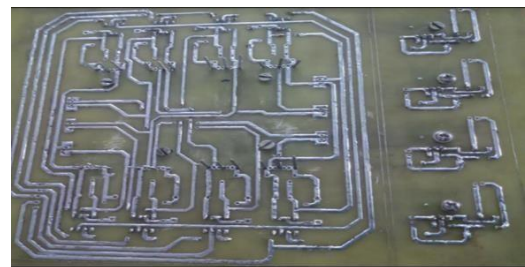
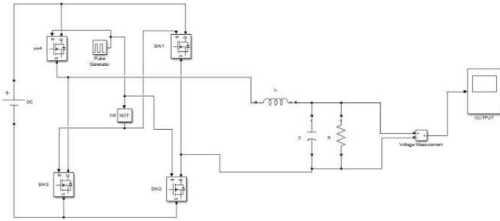

Fig.11 PCB Design Layout

Here the PCB Design Layout and its structure is carried out in KICAD Software. It is a type of Unique Software which is used for the PCB designs

X. RESULTS AND DISCUSSIONS

In this paper, MATLAB/Simulink software is used to simulate the static voltage stabilizer circuit and it shows the complete simulation of the proposed system.



Simulink Circuit for Input mode 1

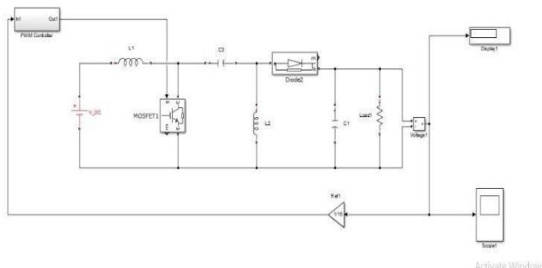
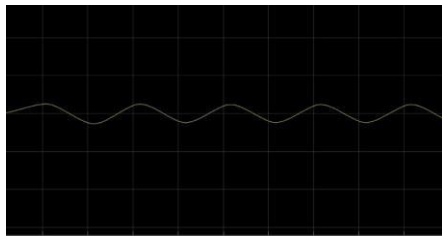

Simulink Circuit for Input mode 2

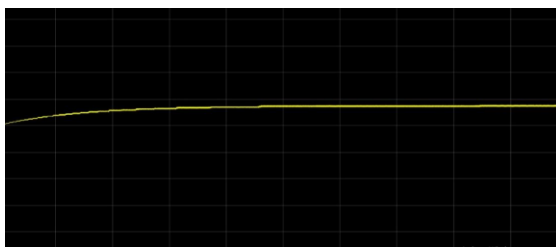

Here the results shows the constant output voltage for a Static Voltage Stabilizer system.

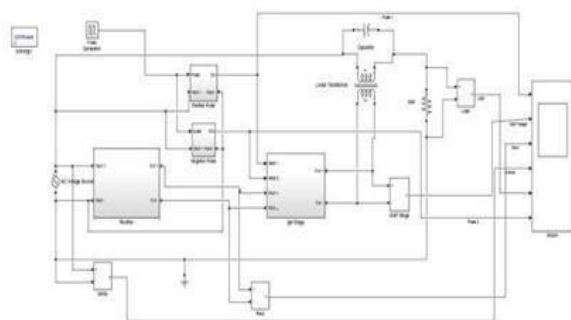

The above circuit shows the main Simulink circuit for the Static Voltage stabilizer system.

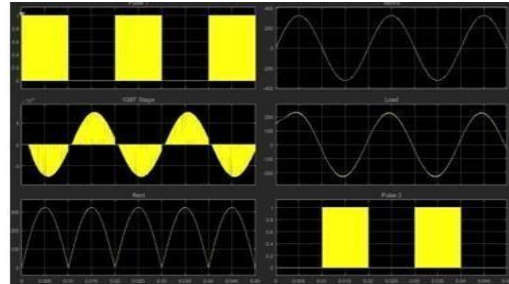

This is the Simulink simulation results for the SVS system.

XI. CONCLUSION

The above paper shows that a Static Voltage Stabilizer is developed and implemented to give constant output voltage. By using MATLAB which is an open loop type or the Simulink software model for the Static Voltage system is implemented. According to this the hardware model is also developed for the above Static Stabilizer system. Here Pulse width modulated type of the signals are generated and then it is fed to IGBT modules and the HCPL driver circuits. To eliminate the noises the electrolytic type of capacitors are used.

REFERENCES

[1] H. Shi, "Static and the reduced-order stabilizers based on the improved state coordinates transformations," The 26th Chinese Control and Decision Conference (2014 CCDC), Changsha, 2014, pp. 439-442.

[2] S.Subrahmanyam V, S. K. Jain and G. Narayanan, "Real-time Simulation of IEEE 10- Generator 39-Bus System with Power System Stabilizers on Miniature Full Spectrum Simulator," 2019 IEEE International Conference on Sustainable Energy Technologies and Systems (ICSETS), Bhubaneswar, India, 2019, pp. 161-166.

[3] C. Albuquerque and R. P. S. Leao, "Evaluation of the behaviour of switch mode power supply and voltage stabilizer under voltage variations of short duration," IEEE 2002 28th Annual Conference of the Industrial Electronics Society. IECON 02, Sevilla, 2002, pp. 117-122 vol.1.

[4] R. C. Schaefer and Kiyong Kim, "Power System Stabilizer Performance With Summing Point tpyVar/Power Factor Controllers," Conference Record of 2006 Annual Pulp and Paper Industry Technical Conference, Appleton, WI, 2006, pp 1-7.