

DESIGN OF CONVENTIONAL CONTROLLER FOR MODIFIED HIGH STEPUP DC-DC CONVERTER USED FOR SOLAR PV SYSTEMS

Nallamekala Gowthami¹, Ravindra Janga²

¹PG Student, Dept. of Electrical and Electronics Engineering, Bapatla Engineering College, Andhra Pradesh, India.

²Assistant Professor, Dept. of Electrical and Electronics Engineering, Bapatla Engineering College, Andhra Pradesh, India.

Abstract –Controller Design issues of non-isolated high voltage gain DC-DC converter used for Standalone PV System has been presented in this paper. The performance of the converter was compared with the designed controller for the converter. The considered converter has been simulated for the input voltage of 15 V and an output voltage of 150 V with 100 W output power. The time response analysis conveys that the proposed converter settles to the steady state voltage and current from the converter with designed controller. The complete analysis about the modeling of PV System and working principle of Converter also presented to get clear view of the considered system.

Keywords: DC-DC Converter, High Step-up, PI Controller, Solar PV Systems.

1. INTRODUCTION

As increasing the demand of electricity, Power Generation by conventional sources increases the greenhouse effect and environmental pollution issues. These are causes obstacle for industrial growth. These issues make the use of renewable energy sources and cause the researchers to move towards the Solar and Fuel cell systems. The photovoltaic (PV) most outstanding one among renewable energy sources due to because it is reliability, low-maintenance and eco-friendly. However, Power Generation from PV systems are reduced due to some issues like partial shading and mismatch condition and low conversion efficiency. Some maximum power point tracking algorithms are used to increase improve the efficiency and the energy harvesting facility. Alternately, to increase the performance of the system, high step up DC-DC converters are used to convert from low voltage to high voltage for required applications [1-5].

Some efforts made using Boost Converter, SEPIC converter and modified SEPIC converter to increase the voltage gain of the converter used solar PV Systems [6]. Moreover, one of the researchers proposed a new Modified Converter for improving the voltage gain of the converter and presented in detailed about the comparison of difference converters. In addition to the topological advancements in the converters, performance of the converters need to be improve my designing the suitable controllers for the DC-DC Converters to get steady state tracking capability and to get better performance from the converters.

The Main objective this paper is to design a controller for the standalone system used for Power generation to deliver the power to DC Load and to present complete details about the working principle and design procedure of the controller for the considered converter. The overview of the considered system is shown in Fig.1.

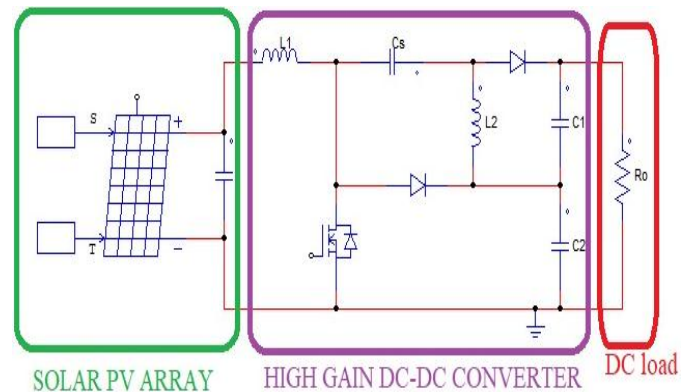

Fig -1: Overview of Considered Standalone System

Organization of this paper is as follow, Section 2 describes the theme of the considered system and modeling of Solar PV System, DC-DC converters operation and its waveforms are presented in Section 3. In Section 4 Design Parameters and open loop, response of the system is presented and performance analysis and results for designed controller are presented in Section 5.

2. Modelling of Solar PV System

The Solar PV System generating the DC Voltage at Low-level values but to drive the Loads High Voltage is required for this purpose a high gain DC-DC Converter is considered to step up the voltage level and the output of this converter is given to Load to drive it. Before going to discuss about the working of considered converter, Modeling of PV is systems need to be addressed to Model it in the software and is presented in sec.2.1.

2.1 Modelling of Solar PV system

The single-diode model is derived using physical principles and is represented by the Fig.2.

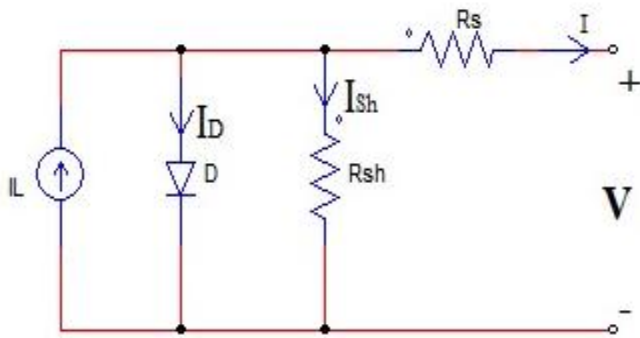

Fig -2: PV Cell Equivalent Circuit

Using Kirchoff's current law, the Current I is written as,

$$I = I_L - I_D - I_{sh} \tag{1}$$

Where I_L represents the light-generated current in the cell, I_D represents the voltage-dependent current lost to recombination and I_{sh} represents the current lost due to shunt resistances. I_D is modeled using the Shockley equation for an ideal diode,

$$I_D = I_0 \left[\exp\left(\frac{V + IR_s}{nV_T}\right) - 1 \right] \tag{2}$$

Where n is the diode ideality factor, I_0 is the saturation current. The thermal voltage given by,

$$V_T = \frac{kT_0}{q} \tag{3}$$

Where k is Boltzmann's constant.

Here, the shunt current is written as

$$I_{sh} = \frac{(V + IR_s)}{R_{sh}} \tag{4}$$

and by combining this and the above equations results in the complete governing equation for the single-diode model,

$$I = I_L - I_0 \left[\exp\left(\frac{V + IR_s}{nV_T}\right) - 1 \right] - \frac{(V + IR_s)}{R_{sh}} \tag{5}$$

Five parameters in this equation are primary to all single diode models:

I_L : light current (A)

I_0 : diode reverse saturation current (A)

R_s : series resistance (Ω)

R_{sh} : shunt resistance (Ω)

n : diode ideality factor.

The output power is given by:

$$P = V \left(I_L - I_0 \left[\exp\left(\frac{V + IR_s}{nV_T}\right) - 1 \right] - \frac{(V + IR_s)}{R_{sh}} \right) \tag{6}$$

With the help of this model, Solar PV System is modeled in MATLAB for desired Output Power.

3. WORKING OF HIGH STEP-UP DC-DC CONVERTER

The proposed converter is shown in Fig. 3, it consists of one switch S, two inductors L_1 and L_2 , two diodes D_0 and D_M , and three capacitors C_1 , C_2 and C_s . The sum of the C_1 and C_2 capacitor's voltages is equal to the output voltage of the converter.

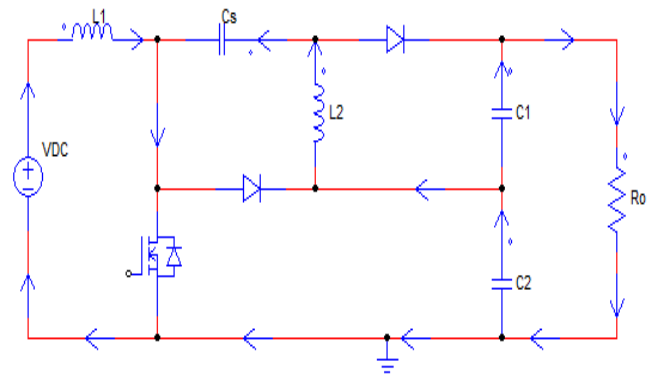

Fig -3: Modified High Gain DC-DC Converter

When the switch is on, the diode D_0 and D_M are reversed biased and the charges are stored in inductors L_1 and L_2 , as shown in Fig. 4.

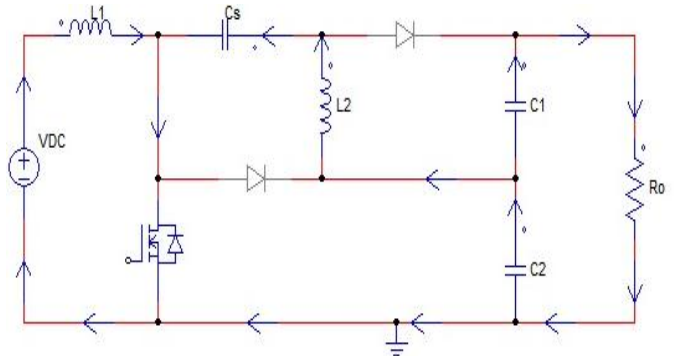

Fig -4: DC-DC Converter during ON State

The input voltage flows through inductor L_1 to the inductor L_2 through C_s and C_2 . The capacitor voltage V_{C2} is equal to the switching voltage. When the switch is off, the diode D_0 and D_M are in forward biased condition and stored energy from inductor L_1 starts discharging, as shown in Fig. 5.

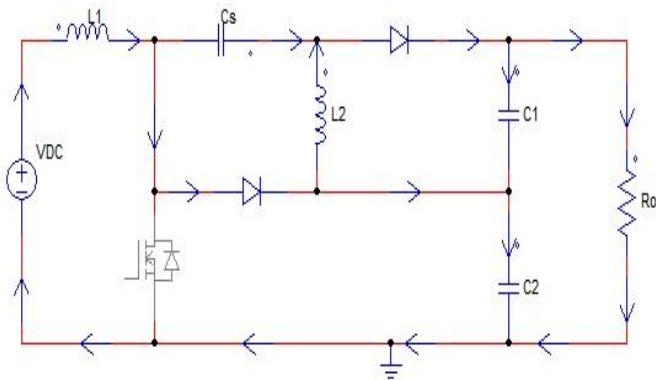

Fig -5: DC-DC Converter during OFF State

The output flows through C_s and C_2 and inductor L_2 discharges the energy through diode D_0 . The switch voltage is almost equal to capacitor voltage C_2 . The main theoretical waveforms of the proposed converter are presented in Fig. 6.

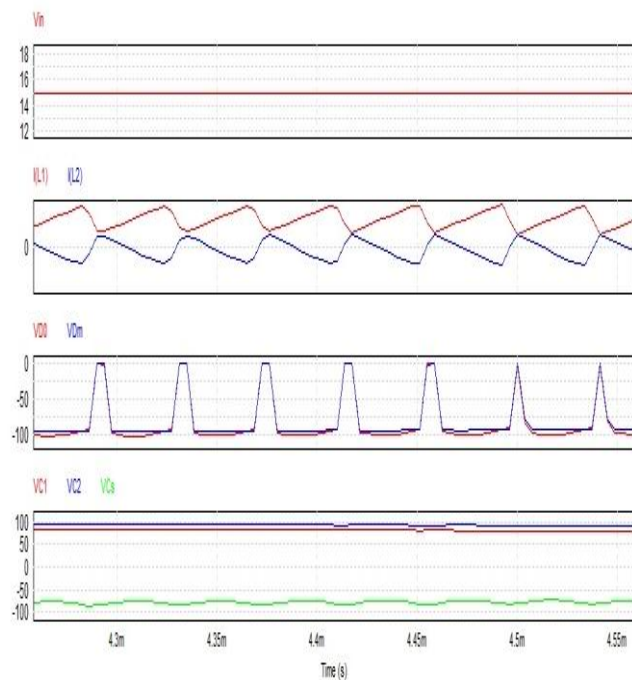

Fig -6: Waveforms of DC-DC Converter

The voltage across the switch and all diodes are equal to the capacitor C_2 voltage. The output voltage is equal to the sum of the capacitor voltage C_1 and C_2 . The duty cycle relation is presented in (7) considering continuous conduction mode operation. Duty cycle relation of the considered converter is a combination of both boost and SEPIC converters [6-7]. The output voltage of the converter is greater than that of the conventional boost and SEPIC converter.

$$D = \frac{(V_{out} - V_{in})}{(V_{out} + V_{in})} \tag{7}$$

The capacitor C_2 voltage V_{C2} is calculated by (8) and is equal to the output voltage of the conventional boost

converter. The switching voltage of the proposed converter was the same as the C_2 capacitor's voltage. During the off condition of the switch the diodes D_0 and D_M were in conduction mode and the relation was obtained as (9),

$$\frac{V_{C2}}{V_{in}} = \frac{1}{1 - D} \tag{8}$$

$$V_{out} = V_{C1} + V_{C2} \tag{9}$$

The voltage across the series capacitor, V_{Cs} and C_1 capacitor voltage, V_{C1} was calculated by (10),

$$V_{Cs} = V_{C1} = V_{in} \left(\frac{D}{1 - D} \right) \tag{10}$$

To get steady response from converter, a controller is required. Before designing a controller, Converter Components are calculated using the desired input and output parameters. The design considerations for the proposed converter,

Input voltage = 15 V,

Output voltage = 150 V,

Output power = 100 W,

Switching frequency = 24 kHz

Table -1: Parameters/Components of the Converter

Parameter/Components	Value	Units
Input Voltage	15	Volts
Output Voltage	150	Volts
Switching Frequency	24K	Hz
Duty Cycle	0.82	---
Output Power	100	Watts
L1,L2	102,102	μ H
C1,C2	50	μ F
Cs	3.37	μ F

The theoretical values estimated and the parameter values of the converter chosen are displayed in Table 1. These parameters were used to obtain the suitable output for the step up conversion in the converters with more reliability.

4. CONTROLLER DESIGN

Considered System with Designed Controller is simulated using the calculated Parameter values in MATLAB Software for 100W output as shown in Fig. 7(a) and in Fig. 7(b). The open loop, output response is observed as in Fig.8.

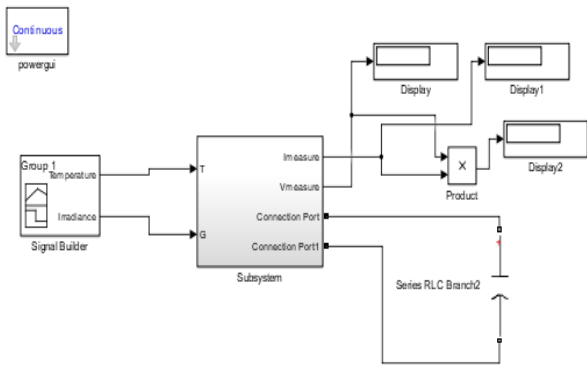

Fig -7 (a): Simulation Circuit of Solar PV System

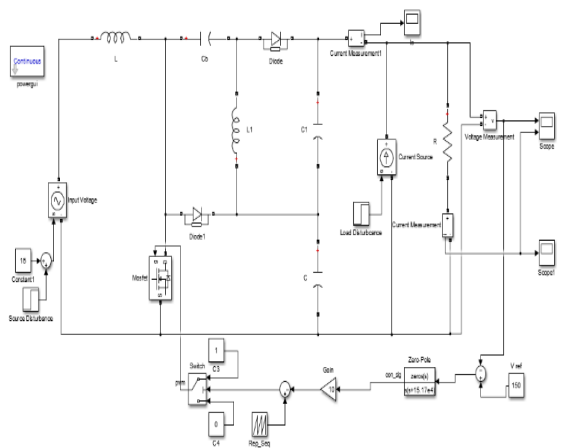

Fig -7 (b): Simulation Circuit of Converter with Controller

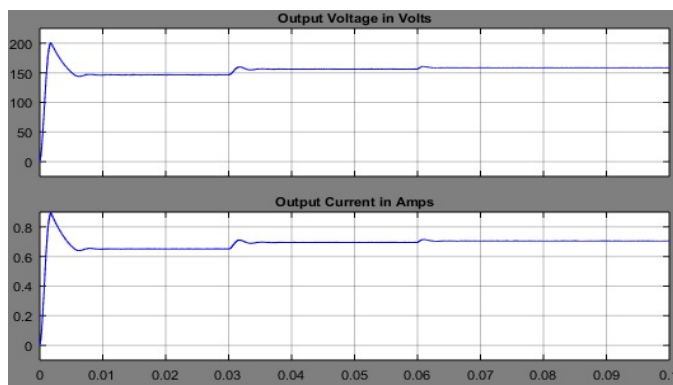

Fig -8: Output Response of Converter without Controller

The MATLAB Simulation shown in Fig.8 for considered system shows the variation in output along with the disturbances occurs at 0.03Sec and 0.06Sec. It shows the necessity of the controller as required values not able to get from converter with the deviations in input, output and parameter variations. Hence to get desired performance from the Converter a Controller is designed with the help of methodology used in [8] and is in the form of equation (11) with gain of 10 and $T_i=0.052$,

$$G_c(s) = K_p \left(1 + \frac{1}{sT_i} \right) \tag{11}$$

With the designed controller, considered system was simulated again and PWM signal is generated to control the output signal and is shown in Fig.9

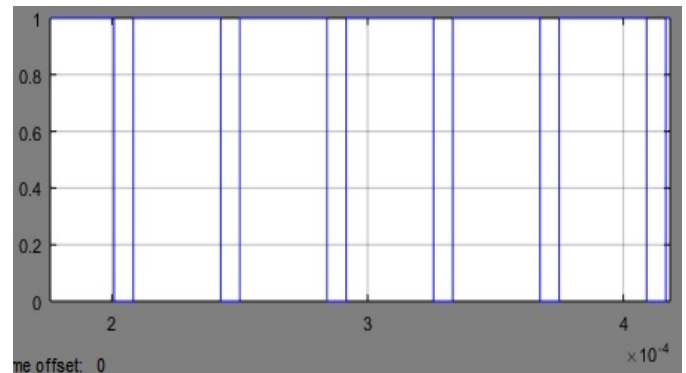

Fig -9: PWM Signal Generated by the Controller

The obtained results of system with PI Controller shown in above Fig.10 shows the achievement of desired response even though source and load disturbances occurs at 0.03 Sec and at 0.06 Sec.

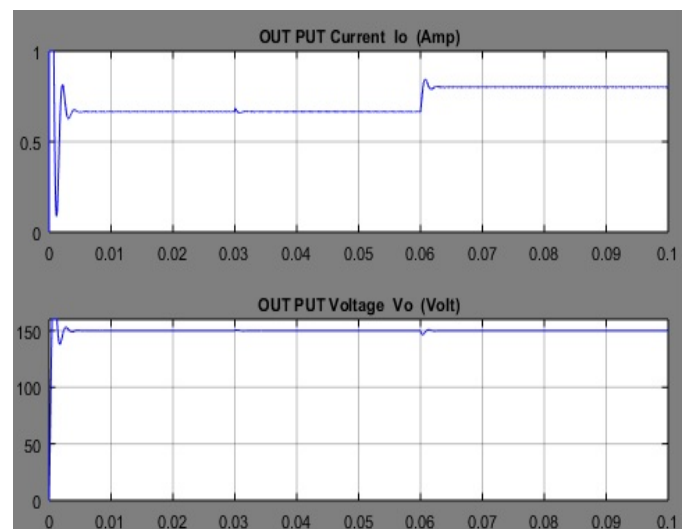

Fig -10: Output Response of Converter with Controller

5. CONCLUSIONS

The high step up non-isolated DC-DC converter is presented in this paper. The output response of the system with designed PI controller confirms the validity of the designed controller. The time response analysis of the proposed converter shows that the output current and voltage characteristics settle to the steady state value even after applying the disturbances at source and load side. The validation of the designed controller for the converter concludes that its performance is better than the models used for renewable energy systems without controller and it can be a good choice for many of the renewable energy system applications with simple design procedure and better performance.

REFERENCES

1. Al-Saffar, M. A., & Ismail, E. H. (2015). A high voltage ratio and low stress DC-DC converter with reduced input current ripple for fuel cell source. *Renewable Energy*, 82, 35-43.
2. Chiang, S. J., Shieh, H. J., & Chen, M. C. (2009). Modeling and control of PV charger system with SEPIC converter. *IEEE Transactions on Industrial Electronics*, 56(11), 4344-4353.
3. Fardoun, A. A., & Ismail, E. H. (2010). Ultra step-up DC-DC converter with reduced switch stress. *IEEE Transactions on Industry Applications*, 46(5), 2025-2034.
4. Figueres, E., Garcerá, G., Sandia, J., Gonzalez-Espin, F., & Rubio, J. C. (2009). Sensitivity study of the dynamics of three-phase photovoltaic inverters with an LCL grid filter. *IEEE Transactions on Industrial Electronics*, 56(3), 706-717.
5. Gules, R., Dos Santos, W. M., Dos Reis, F. A., Romaneli, E. F. R., & Badin, A. A. (2014). A modified SEPIC converter with high static gain for renewable applications. *IEEE Transactions on Power Electronics*, 29(11), 5860-5871.
6. Subramani Saravanan, Neelakandan Ramesh babu , "A modified High step-up non-isolated DC-DC Converter for PV Application" *Journal of Applied Research and Technology*, 15(2017), 242-249.
7. Hart, D. W. (2011). *Power Electronics*. India, Pakistan, Nepal, Bangladesh, Sri Lanka, Bhutan: Tata McGraw-Hill.
8. Ravindra Janga and Nagalakshminarayana Alluru, "An Improvement in Performance of Grid Connected PV System with High Step-up DC-DC Converters" *European Journal of Advances in Engineering and Technology*, 2018, 5(7): 427-436.