

Home Appliance Control System using Internet of Things and Artificial Intelligence

Ms. Sneha Menon

Final Year Student, Department of Electronics and Telecommunication Engineering, SIES GST, Nerul, India.

Abstract “An automated and networked house is one during which every appliance are often remotely managed [4] from anywhere on the web with an easy Web browser”. the overall goal of the automatic-home movement is to use networking technology to integrate the devices, appliances and services found in homes in order that the whole domestic lebensraum are often controlled centrally or remotely. Automation is a procedure or a technique, method, or system of running or controlling a process by electronic devices with a minimal human involvement. The elemental of building an automation system for an office or house is increasing day-by-day with numerous benefits. Industrialist and researchers are working to create efficient and affordable automatic systems to watch and control different machines like lights, fans, AC supported the need. Automation makes not only an efficient but also a cheap use of the electricity.

Key Words: Smart air conditioner, Internet of Things, Home automation

1. INTRODUCTION

As a result of growing technological development and urbanization energy demand increases rapidly. Its negative environmental impact and limits in production require energy savings. Since a big part of electricity consumption occurs in residentials, proper use of electricity in homes plays important role to contribute these requirements. It is impossible for someone to predict that IoT would come into existence in a very short period. (IoT) is one of the most valuable and useful technologies which can be used for connecting, controlling and managing intelligent objects which are connected. In this work, a smart Air Conditioner scheme is proposed and its adaptation to a Smart Home system is presented. to Internet through an IP address Smart home is one in which various electronic and electric appliances are wired up to a central computer control system so that they can either be switched on and off at certain times [2]. Cloud computing is a rapidly growing technology where resources such as storage devices, platform and applications are shared over the internet used

By multiple users in small and medium business. Cloud services can be provided and delivered remotely by vendors such as Amazon or Microsoft as “public clouds”, or the resources are designed, installed, monitored and controlled internally as “private clouds”. Cloud data retrieval is an important service to be considered as certain specific data

files the users are interested during a given session must be retrieved in an efficient way and quickly[3]. In this project we are connecting the various sensors and devices to Node MCU which is connected with IFTTT and the devices are operated as per the voice commands given through Google Assistant.

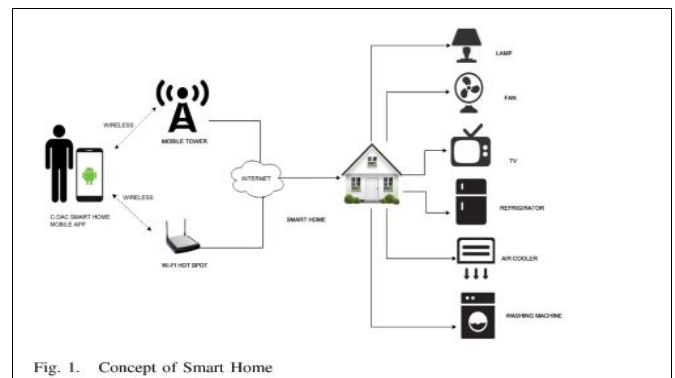

Fig. 1. Concept of Smart Home

2. PROPOSED METHODOLOGY

An AC (Air Conditioner) which was once considered to be a luxury item and was only to be found in big hotels, movie halls, restaurants etc. But, now almost everyone features a AC in our home to beat out the summer/winter and people who have it, worry about one common thing. That’s their high electricity consumption and charges thanks to it. While doing this project we get to make an Automatic Temperature negative feedback circuit that would save the electricity charges by varying the AC temperature automatically by supporting the room temperature.

By varying the set temperature periodically we will avoid making the AC to figure for lower temperature values for an extended time and thus making it consume less power. Most people would have faced a situation where they’ve to change the Air Conditioner’s set temperature to different values during different times of the day, so on keep us comfy throughout. To perform this process this project uses a Temperature sensor (DHT11) which reads this temperature of the space and supported that value it’ll send commands to the AC through an IR blaster almost like the AC’s Remote. The AC will react to those commands as if it’s reacting to its Remote and thus adjust the temperature. As your room’s temperature changes, the Arduino also will adjust your AC’s set temperature to take care of your temperature in only the way we would like it to be.

The block diagram of the Proposed system is as Follows:

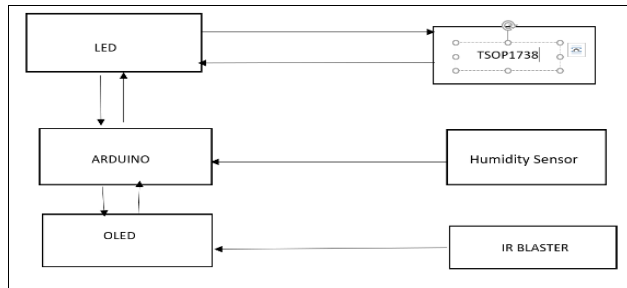
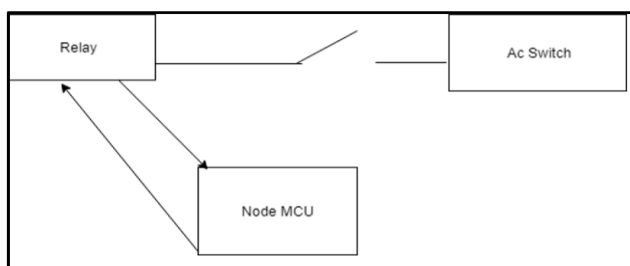
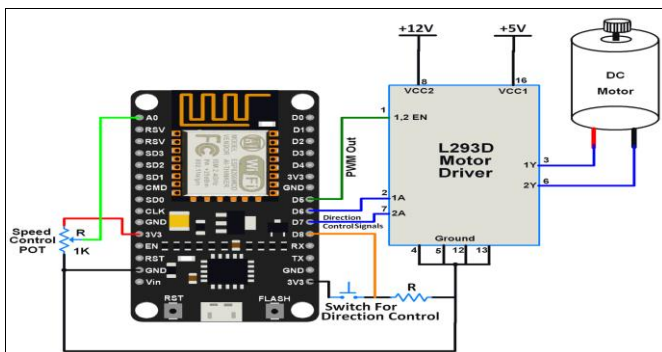

Fig: a. Automatic Temperature Control



b. Fig: Google Assistant (A.I)

Swing control for AC



NodeMCU interface with DC Motor through L293D driver NodeMCU based ESP8266 can be used to control the speed and rotational direction of DC Motor. NodeMCU has PWM feature on its GPIO pins using which we can control DC motor. To know about NodeMCU PWM refer NodeMCU PWM with Arduino IDE or NodeMCU PWM with ESPlorer IDE.

The circuit consists only of LED, resistor, HC-05 and Arduino. The long "leg" of the LED will be connected to the 5V through the resistor on Arduino pin number 13 while the shorter "led" will be connected to the GND. For the HC-05, the VCC is connected to 5V, GND to GND, RX of HC-05 to Arduino TX, while TX of HC-05 to Arduino RX.

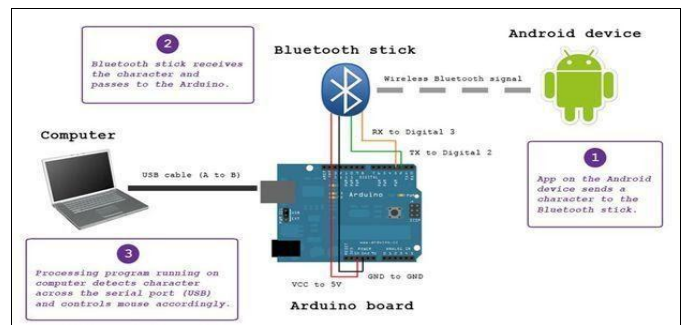

3. ADVANTAGES

- It will allow you to control your Air conditioner and cool your home from anywhere using your own devices like mobiles, tablets, desktops etc
- It also allows you to restart your air conditioner from anywhere and at anytime.
- It saves the electricity and is energy efficient.

4. RESULT

The Google Assistant may be a virtual assistant developed by Google that's primarily available on mobile and smart home devices. Unlike Google Now, the Google Assistant can engage in two-way conversations.

Assistant initially debuted in May 2016 as a part of Google's messaging app Allo, and its voice-activated speaker Google Home. After a period of exclusivity on the Pixel and Pixel XL smartphones, it began to be deployed on other Android devices in February 2017, including third-party smartphones and Android Wear, and was released as a standalone app on the iOS OS in May. Alongside the announcement of a software development kit in April 2017, the Assistant has been, and is being, further extended to support an outsized sort of devices, including cars and smart home appliances. The functionality of the Assistant also can be enhanced by third-party developers.

Users primarily interact with the Google Assistant through natural voice, though keyboard input is additionally supported. In the same nature and manner as Google Now, the Assistant is in a position to look the web, schedule events and alarms, adjust hardware settings on the user's device, and show information from the user's Google account. Google has also announced that the Assistant are going to be ready to identify objects and gather visual information through the device's camera, and support purchasing products and sending money, as well as identifying songs.



Fig a Switching Light and Ac with google assistant

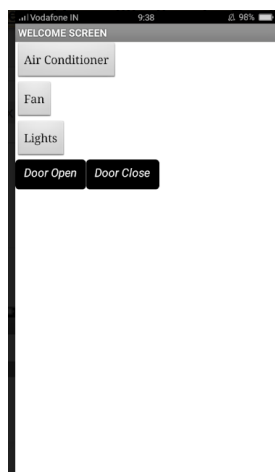

Fig b App for controlling appliances

5. CONCLUSIONS

With growing technological development and urbanization, energy demand increases rapidly. Since a big part of electricity consumption occurs in residentials, proper use of electricity in homes plays important role in efficient use of energy. Smart Home is defined as a residential equipped with smart electrical appliances, sensors and a controller unit.

Smart appliances offering energy savings and improved user comfort are indispensable part of Smart Homes. Due to global warming, increasing comfort requirements and its high energy consumption compared to other appliances, smartness and Smart Home integration of Air Conditioner is very important for both user comfort and energy savings. In this work, a smart Air Conditioner scheme is proposed and its adaptation to a Smart Home system is presented. Firstly, working principles of s-AC and its advantages compared to AC are explained. Then, Petri net model of the s-AC is introduced to enable a good general view of the operation of the s-AC and its adaptation to SH. Moreover, a program is

prepared by using Keysight VEE 9.3 software for monitoring and controlling s-AC. Experimental results significant savings in electricity bills as well as improving user comfort.

6. ACKNOWLEDGEMENT

This work was supported by Expertshub Industry Skill Development centre

7. REFERENCES

- [1] L. E. Holloway and B. H. Krogh, "Controlled petri nets: A tutorial survey," 1994.
- [2] T. Murata, "Petri nets: Properties, analysis and applications," Proceedings of the IEEE, vol. 77, no. 4, pp. 541–580, Apr 1989.
- [3] S. Shao, M. Pipattanasomporn, and S. Rahman, "Development of physical-based demand response-enabled residential load models," Power Systems, IEEE Transactions on, vol. 28, no. 2, pp. 607–614, May 2013.
- [4] M.-L. Chan, E. Marsh, J. Yoon, and G. Ackerman, "Simulation-based load synthesis methodology for evaluating load-management programs," Power Apparatus and Systems, IEEE Transactions on, vol. PAS-100, no. 4, pp. 1771–1778, April 1981.
- [5] E. Klaassen, C. Kobus, M. van Huijkelom, J. Frunt, and H. Sloodweg, "Evaluation of washing machine load potential for smart grid .integration," in Power Engineering Conference (UPEC), 2013 48th International Universities', Sept 2013, pp. 1–6.
- [6] M. Zehir and M. Bagriyanik, "Demand side management by controlling refrigerators and its effects on consumers," Energy Conversion and Management, vol. 64, pp. 238–244, 2012
- [7] —, "Demand side management potential of refrigerators with different energy classes," in Universities Power Engineering Conference (UPEC), 2012 47th International, Sept 2012, pp. 1–4.
- [8] M. Stadler, W. Krause, M. Sonnenschein, and U. Vogel, "Modeling and evaluation of control schemes for enhancing load shift of electricity demand for cooling devices," Environ Model Softw, vol. 24, pp. 285– 295, 2009.
- [9] M. Pipattanasomporn, M. Kuzlu, S. Rahman, and Y. Teklu, "Load profiles of selected major household appliances and their demand response opportunities," Smart Grid, IEEE Transactions on, vol. 5, no. 2, pp. 742–750, March