

HARMONIC RESPONSE ANALYSIS OF G+2 STOREY STRUCTURE BY ANSYS

Anurag Singh¹, Dinesh Sen²

¹Post Graduate Student, Vishwavidyalaya Engineering Collage, Lakhanpur, Ambikapur

²Professor, Dept. of Civil Engineering, Vishwavidyalaya Engineering Collage Lakhanpur, Ambikapur

Abstract - The work is based on dynamic response of multiple degrees of freedom (MDOF) system. This work studies the Harmonic Response by applying the force in the structure. For the MDOF system we have taken G+2 story building to do structure response. The dynamic analysis has done for both Undamped & Damped free and forced system applied for harmonic and transient spectrum and also analysis the static & response spectrum of multiple degrees of freedom (MDOF) system. In case of Damped system we have done under damping system. The deformation shape & graph obtained for undamped and damped stages. Natural frequency is determined by the both theoretically calculation and analysis by ANSYS. The ANSYS is the modelling and simulation software is used to perform the static & dynamic response. The Mode is used by ANSYS to calculate the structure response.

Key Words: static & dynamic response, multiple degrees of freedom (MDOF) system, harmonic and transient spectrum, Natural frequency, ANSYS.

1. INTRODUCTION

Structural dynamics is Vibration based and the vibration caused by dynamic loads; it includes any loading which varies with time.

Some forces that give dynamic waves on the structure are environmental sources like wind, earthquakes and waterways. The structure responds to a given dynamic excitation depends upon the nature of excitation and the dynamic characteristics of the structure. Mode shapes is structural vibration condition when excited at their resonant frequencies. Mode shape or are used in structural dynamics. Study or understanding the mode shapes, all the possible types of vibration can be predicted.

2 NATURAL FREQUENCIES AND MODE SHAPES:-

Harmonic response analysis based on frequencies.

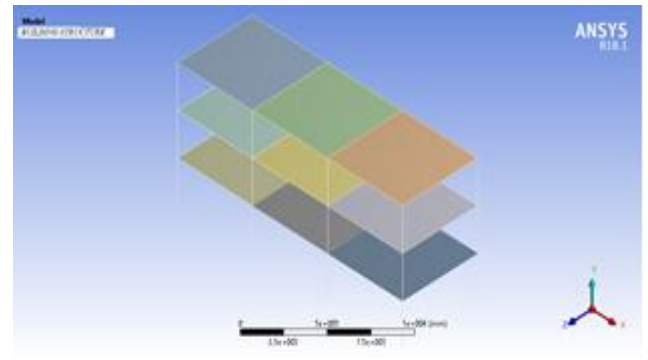

Fig -01: building structure

To perform dynamic analysis determines natural frequencies.

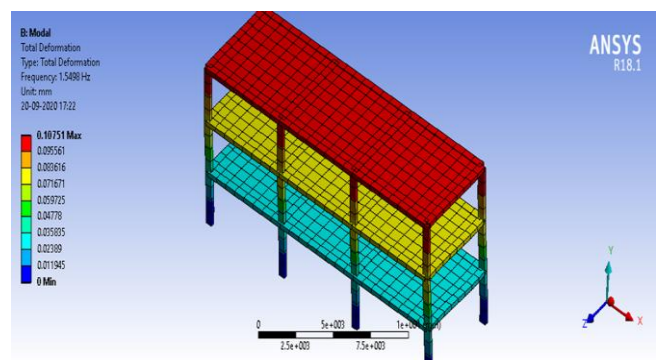

Fig -1: Mode 1

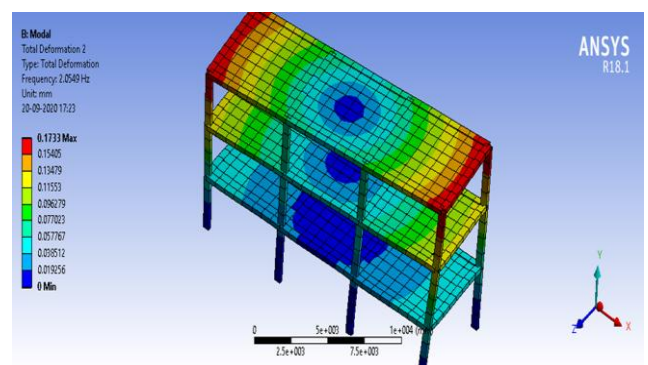

Fig -2: Mode 2

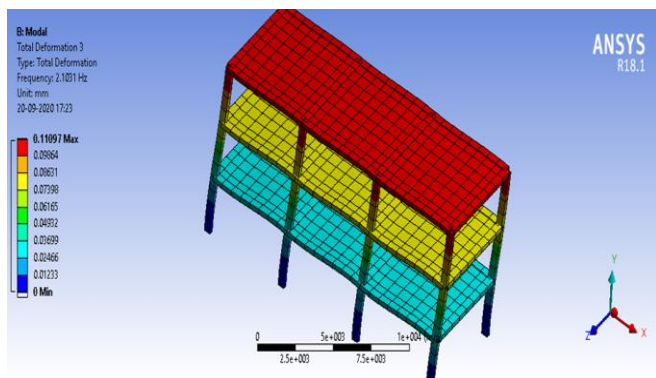

Fig -3: Mode 3

Table 1 Natural frequencies and mode shapes

Mode Shapes	Frequency
1	1.5498
2	2.0549
3	2.1031

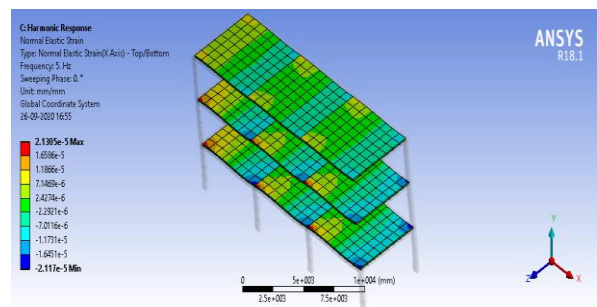

Fig -5: Normal Elastic strain at undamped system

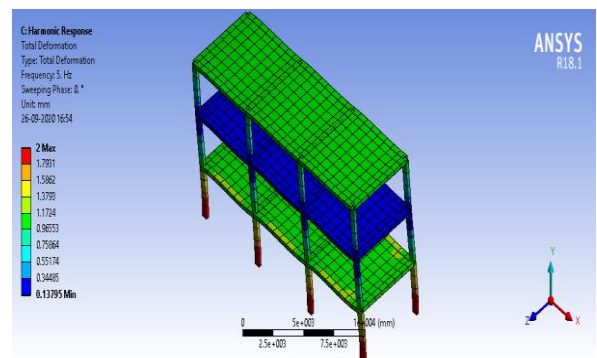

Fig -6: Total Deformation at undamped system

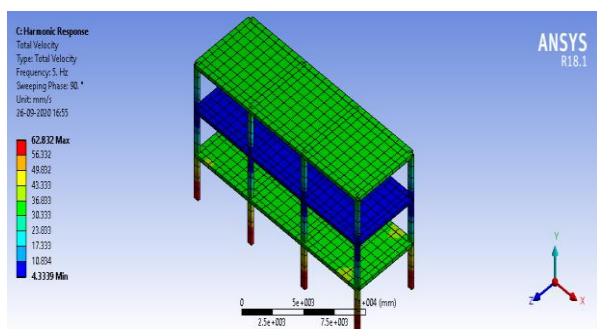

Fig -7: Total velocity at undamped system

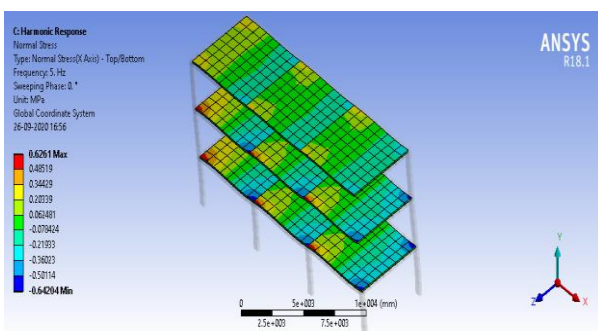

Fig -4: Normal stress at undamped system

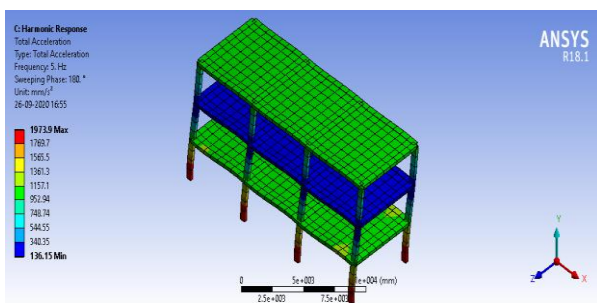

Fig -8: Total Acceleration at undamped system

3 HARMONIC RESPONSE ANALYSES

A harmonic analysis is used to determine the response of the structure under a steady-state sinusoidal (harmonic) loading at a given frequency.

Force 1 & force 2 applied, both force is 40000N in x direction Both forces applied for undamped & damped conditions. Geometry selection is 8 vertices, 9 faces, 80 edges. Earth gravity selected in the -Y direction. Also acceleration is provided. Column is fixed supported

3.1 Undamped Harmonic Response:-

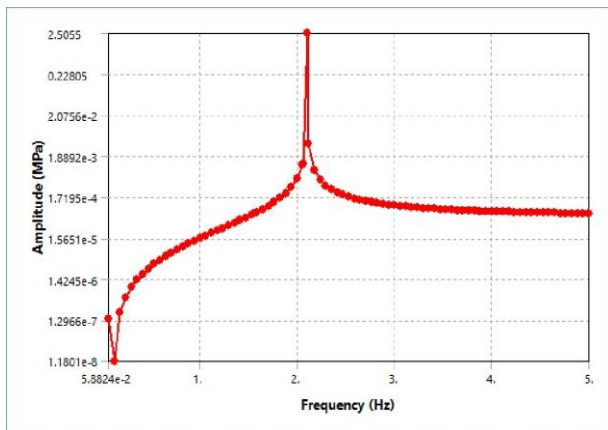

Fig -9: Frequency response 1 for undamped system

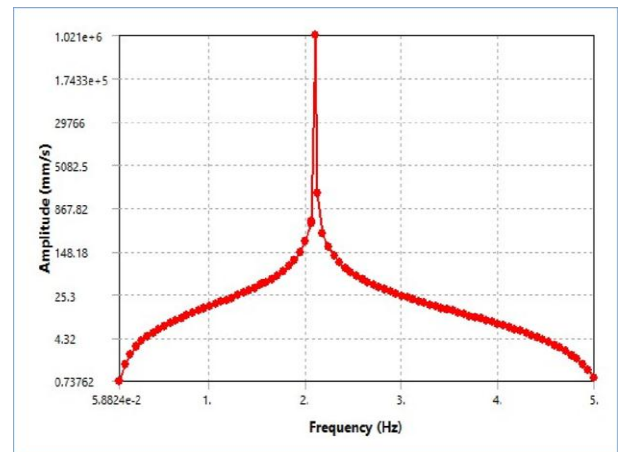

Fig -12: Frequency response 4 for undamped system

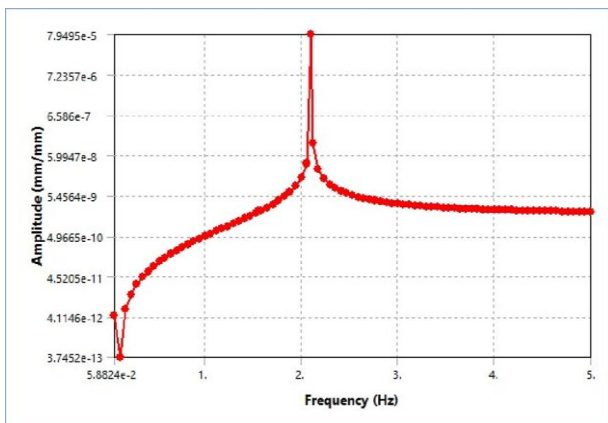

Fig -10: Frequency response 2 for undamped system

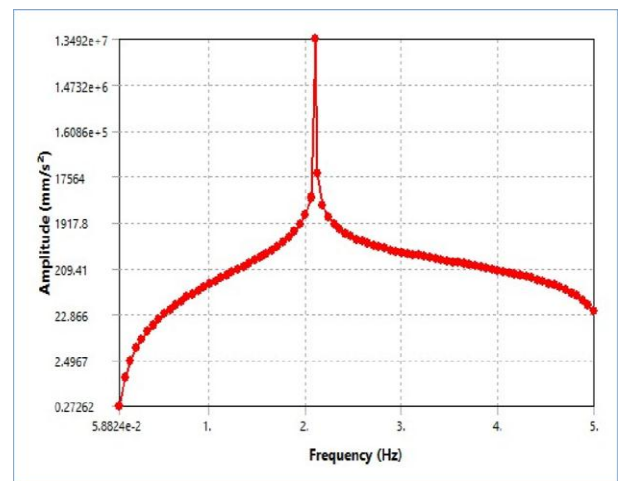

Fig -13: Frequency response 5 for undamped system

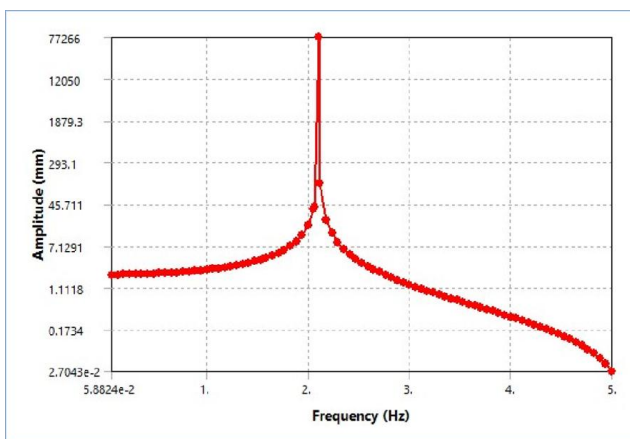

Fig -11: Frequency response 3 for undamped system

3.1.1 Maximum Amplitude obtained for Undamped system:-

Table 2 Maximum amplitude obtained for undamped system

Type	Normal Stress	Normal Elastic Strain	Total deformation	Total velocity	Total acceleration
Maximum Amplitude	0.6261 MPa	2.1305e-005 mm/mm	2. mm	62.832 mm/s	1973.9 mm/s ²

3.1.2 Frequency and Maximum Amplitude value obtained for Undamped system:-

Table 3 Frequency and Maximum Amplitude value for Undamped system

Type	Normal Stress	Normal Elastic Strain	Directional deformation	Directional velocity	Directional acceleration
Maximum Amplitude	2.5055 MPa	7.9495e-005 mm/mm	77266 mm	1.021e+006 mm/s	1.3492e+007 mm/s ²
Frequency	2.1031 Hz				

3.2 Damped Harmonic Response:-

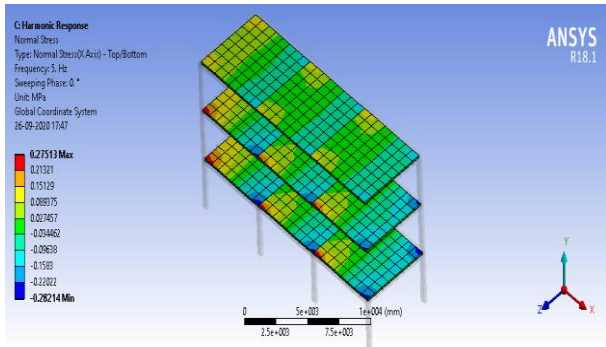

Fig -14: Normal stress at damped system

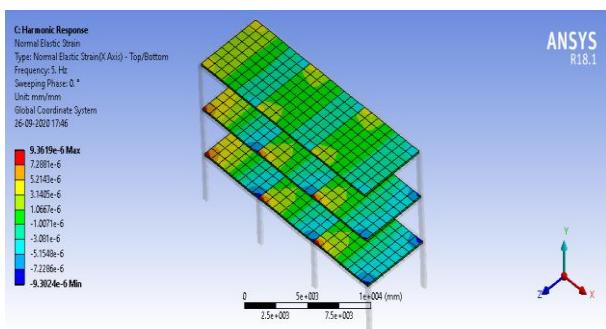

Fig -15: Normal elastic strain at undamped system

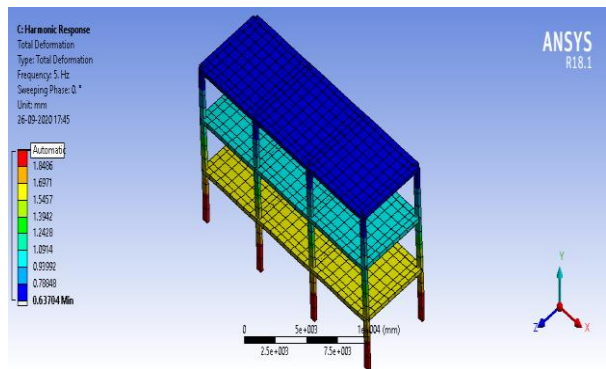

Fig -16: Total Deformation at damped system

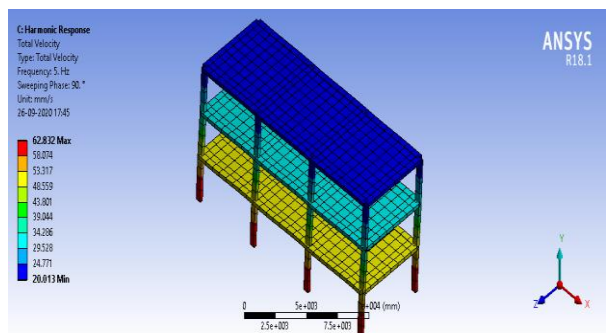

Fig -17: Total Velocity at damped system

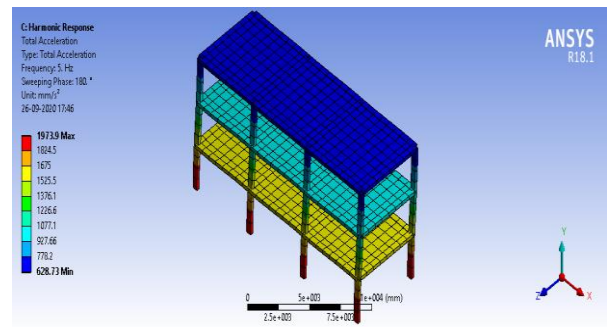

Fig -18: Total Acceleration at damped system

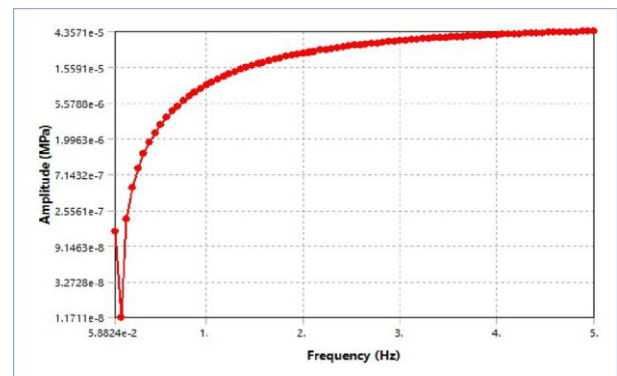

Fig -19: Frequency response 1 for damped system

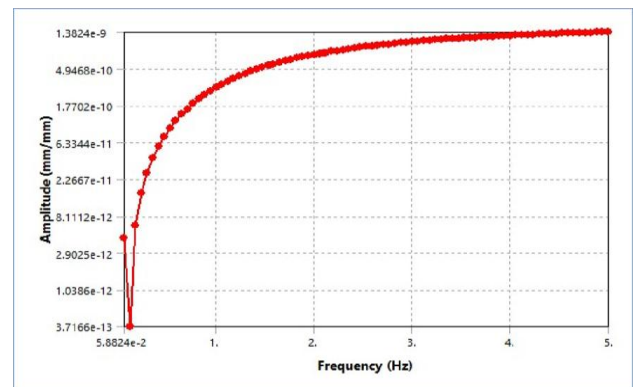

Fig -20: Frequency response 2 for damped system

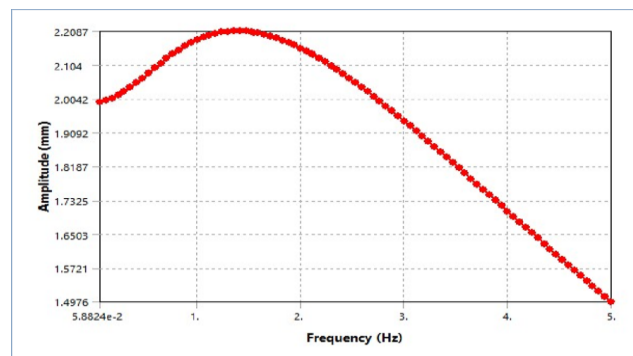

Fig -21: Frequency response 3 for damped system

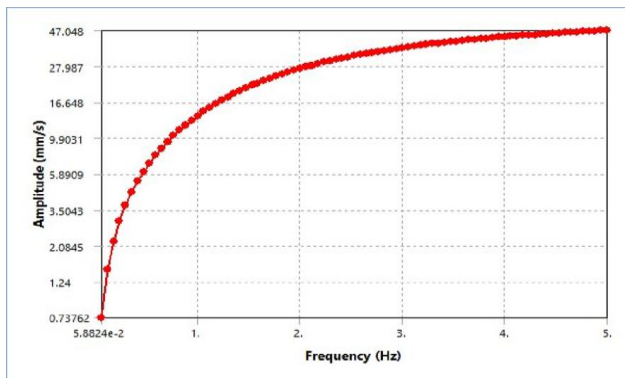

Fig -22: Frequency response 4 for damped system

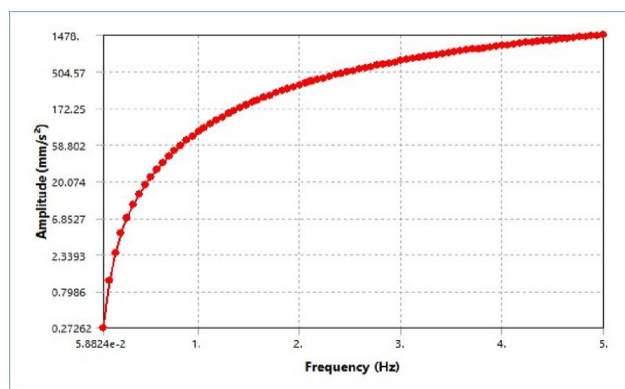

Fig -22: Frequency response 4 for damped system

3.2.1 Maximum Amplitude obtained for damped system:-

Table 4 Maximum Amplitude obtained for damped system

Type	Normal Stress	Normal Elastic Strain	Total deformation	Total velocity	Total acceleration
Maximum Amplitude	0.27513 MPa	9.3619e-006 mm/mm	2. mm	62.832 mm/s	1973.9 mm/s ²

3.2.2 Frequency and Maximum Amplitude obtained for damped System:-

table 5 Frequency and Maximum Amplitude obtained for Damped System

Type	Normal Stress	Normal Elastic Strain	Directional deformation	Directional velocity	Directional acceleration
Maximum Amplitude	4.3571e-005 MPa	1.3824e-009 mm/mm	2.2087 mm	47.048 mm/s	1478. mm/s ²
Frequency	5. Hz		1.4118 Hz	5. Hz	

4. CONCLUSIONS

Natural frequencies and mode shapes obtained by Ansys.

The Harmonic response of undamped and damped system of G+2 building has been performed as a result maximum and minimum amplitude of normal stress, normal elastic strain, total deformation, total velocity, and total acceleration. Also frequency vs. amplitude graph obtained which shows the peak value at a particular frequency the point on undamped condition after applied damping the frequency vs. amplitude the graph shows how the damping decreases the amplitude of the frequency curve.

REFERENCES

- [1] S.R. Damodarasamy, S. Kavitha (2009), "Basics of Structural Dynamics and Aseismic Design" PHE Learning Private Limited, New Delhi.
- [2] Biswal K. C., Bhattacharya S. K. and Sinha P. K., "Free vibration analysis of liquid filled tank with baffles", Journal of Sound and vibration, 259 (1), (2003).
- [3] Agarwal, Pankaj and Shrikhande, Manish, "Earthquake resistance design of structures", New Delhi, PHI Learning, 2008
- [4] Pankaj Agrwal & Manish Shrikhande., "Earthquake Resistant Design of Structures" Prentice Hall of India, New Delhi.
- [5] Anil K. Chopra, "Dynamics of Structures" Pearson Education India.Delhi,(2003)
- [6] Dinesh sen & Anosh kujur (2018),"Study the effect of transient vibration on damped & undamped multi-storey building with equivalent mass-spring system performed by ANSYS" International journal of research and analytical reviews, Volume 6 Issue 1, pp. (595-653).
- [7] ANSYS User's Manual (2017) Swanson Analysis System Inc.
- [8] Salman s. baig & Mamta mogali (2014),"Harmonic response analysis of multistory building" International journal of current engineering and technology, Volume 4.
- [9] Keyavan Ramin & Mitra Fereidoonfar(2015),"Finite element method of modeling and nonlinear analysis for seismic assessment of off-diagonal steel breced RC frame" International journal of concrete structure and material, Volume 9.PP.(89-118)
- [10] Mohammad al bukhari & Mohammad hadi abd hallim (2015),"Determination of natural frequencies through modal and harmonic analysis of space frame race car chassis based on ANSYS" American journal of engineering and applied sciences.

- [11] Yong chang Yu & Shuaijun Zhang(2017), "Modal and harmonic response analysis of key components of Ditch device based on ANSYS" ELSEVIER-Procedia engineering. Volume no. 174,PP.(956-964)