

# Automatic Energy Consumption Controlled in EB Sector using PLCC

Vaishnavi M. Salwan<sup>1</sup>, Shubham B. Wankhade<sup>2</sup>, P. V. Raut<sup>3</sup>, P. V. Kale<sup>4</sup>

<sup>1</sup>Student, Dept. of Electrical Engineering, DES'S COET, Dhamangaon Rly

<sup>2</sup>Student, Dept. of Electrical Engineering, DES'S COET, Dhamangaon Rly

<sup>3</sup>Professor, Dept. of Electrical Engineering, DES'S COET, Dhamangaon Rly

<sup>4</sup>Professor, Dept. of Electrical Engineering, DES'S COET, Dhamangaon Rly

\*\*\*

**Abstract** – With the different progresses in stack estimating strategies, presently a day it is conceivable to perform stack planning successfully. Advanced day remote communication procedures are supplanting the more seasoned wire based frameworks. In this framework it is proposed to execute an robotized framework utilizing microcontroller & PLCC for the smooth operation of control era & control. The class proposes the microcontroller based communication framework for Vitality dealing with and Vitality Administration at the customer conclusion. The most objective of the class is centered on the application of PLCC (Control Line Carrier Communication). The framework employments the existing organize of control line to carry the control information with the help of DTMF (Double Tone Multi-Frequency) in arrange to control the stack conjointly to insinuate the same to the customer. In case the shopper does not pay the charge at that point a elegance period of 24 hours will be given.

**Key Words:** Band Pass Filter, Encoder, Decoder, Dual Tone Multi-Frequency, Power Line Carrier Communication Voltage Control Oscillator.

## 1. INTRODUCTION

In show age of data innovation show center is on both creation as well as scattering of data. In arrange to able to reach the conclusion clients for arrangement of data, the prevalent implies are incorporate phone wires, Ethernet cables, and fiber optics, remote and partisan innovations. Each of these has confinement of taken a toll zand accessibility to reach most extreme number of clients. PLCC is control line carrier communication framework in which utilize all sort of control carrying lines for illustration tall pressure, moo control for telephonic communication in method. This innovation for the control controlling and administration advantage of utilize of control lines as a information transmission medium is that each domestic and building as of now prepared with control lines. There's a few advances as of now in advertise say SCADA (supervision control and information procurement), but these innovations are exceptionally costly as regard to the technology. This contains a combination of microcontroller with sensors and utilize control line as a medium to require information and communication. The presentation centered on control line carrier communication framework (PLCC) i.e. transmission of discourse and information tweaked with tall recurrence flag (50 to 500 KHz) over the power line

conductors. The essential PLCC circuits, its component, their working standards are presented. There are a few strategies can be executed like GSM (Worldwide Framework for Versatile communication), PLCC etc. The impeding of GSM is its taken a toll, tower development, reestablishment SIM framework, recreation of supply line and another downside is that the signals are not come to appropriately. But in PLCC strategy, the development is comparatively simple. The utilization of the transmission line to inform the client that has not paid the charge however. So, partitioned laying of communication line isn't essential.

Hence, utilizing PLCC the control of association and detachment of the stack can be done from the substation itself. In the event that buyer comes up short to pay the power charge an insinuation will be passed with respect to disengagement of supply together with elegance period of 24 hour. The PLCC framework is time efficient. The working taken a toll of this framework is exceptionally less additionally quick activities can be taken utilizing this class within the EB division.

## 2. BLOCK DIAGRAM

The transmitting equipment's are utilized to send the un-incorrupt carrier wave flag to the right put or to the goal. And these signals are to be transmitted with the assistance of the display supply lines in that put. The accepting portion is basically a shopper premises. It comprises of band pass channel, FM demodulator, tone decoder, separation transformer, etc. The transmitted flag is collected and its checks the transmitted flag with the client id. The association and detachment flag are to be transmitted in these ranges through the supplies. With the assistance of microcontrollers, electronic switch, tone generator, VCO, isolation transformer and band pass capacitors. These electronic things are arranged or display within the transmitting segment. These equipment's are utilized to send the un-incorrupt carrier wave signal to the proper put or to the goal. And these signals are to be transmitted with the assistance of the show supply lines in that place.

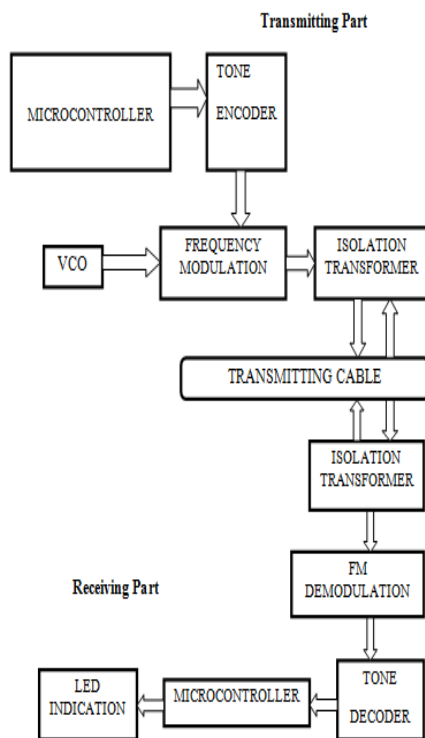

2.1 Connection of Transmitting and Receiving Part with Power Line

The transmitting part is mostly start from the sub stations situated nearer to the residential areas. The substation may consist of larger size equipment and step down transformers. The step-down transformers may have a range of 33kv/11kv. The primary side receives the 33kv supply and it step-downs the supply into 11kv in the secondary of the transformer. The 11kv supply is given to the primary side of the distribution transformers on the road side. It is also a step-down transformer the secondary of the transformer produce 440v supply with 4 wire system. The primary of the transformer is connecting in delta structure and the secondary of the transformer is connected in star structure. The transmitting side had consisted of the following equipment's such as to send the signal to the receiving side to connect or disconnect the supply to the consumer terminals.

Following component are used to generate carrier signal wave

- a) 4\*4 matrix keypad
- b) Microcontroller
- c) Tone generator
- d) Frequency modulator
- e) Operational amplifier
- f) 16 character 1 line LCD display
- g) VCO

With the help of the above combined equipment's only the un-interrupted carrier signal wave is generated. And it allows sending it to the supply line to the consumer terminals. The carrier wave is send with the frequency of

150KHZ. With the supply line then only the carrier wave travels the long distance covered around the substation.

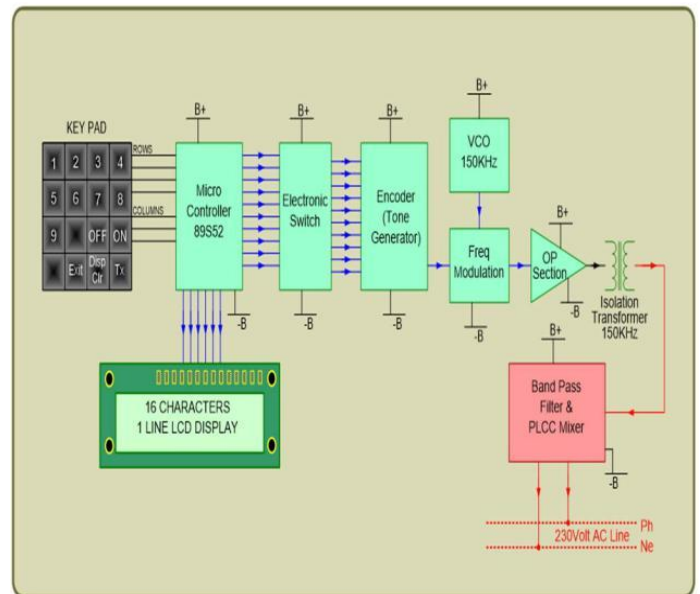

2.2 Transmitting Part

### 3. METHODOLOGY

The framework is centered on the application of PLCC for farther gadget control at shopper premises. The demonstrate works at a run of 150 KHz carrier recurrence infused and extricated in 230V low-tension control line of the same stage to actuate the inaccessible gadget at the shopper conclusion to switch ON/OFF the approaching control supply. The MT8870D/MT8870D-1 could be a total DTMF collector joining both the band part channel and computerized decoder capacities. Exchanged capacitors are utilized as moo and tall gather channels. The decoder employments computerized tallying strategies to identify and translate all 16 DTMF tone sets into a 4-bit code. Tone encoder avoid distortions like consonant and other exterior sounds within the carrier flag. It produces diverse sound recurrence waves with agreeing to the keys squeezed and the frequencies are presently isolated and the transmitted information is permitted to pass through the tone decoder. Here the tone is send in conjunction with the information is isolated and the transmitted information is gotten to the Microcontroller.

#### 3.3: ADVANTAGES

- i) Construction is easy.
- ii) PLCC system is time efficient.
- iii) Operation cost of this concept is very low.
- iv) Immediate action can be done.
- v) Separate lying of communication line is not necessary.

#### 3.4: DISADVANTAGES

- i) Fault causes due to transmission line.
- ii) Distortion in power line due to wind.

### 3.5: APPLICATION

- i) It is microcontroller based communication system used for energy handing and energy management at the consumer end.
- ii) It is used to control a load and gives the intimation to consumer.

### 4. CONCLUSION

PLCC is control line carrier communication framework in which utilize all sort of control carrying lines for case tall pressure, moo control for telephonic communication in procedure. In this way, utilizing PLCC the control of association and detachment of the stack can be done from the substation itself. In case customer comes up short to pay the power charge an hint will be passed with respect to disengagement of supply at the side elegance period of 24 hour. The PLCC framework is time efficient. The working fetched of framework is exceptionally less additionally quick activities can be taken utilizing this framework within the EB segment.

### REFERENCES

- [1] A. A. Abou, A.Zein El-Din, S. R. Spea, S.R , "Optimal load shedding in power systems,"Eleventh International Middle East Power Systems Conference, Volume 2, 2006, pp. 568 – 575.
- [2] A. Saffarian, M. Sanaye-pasand, H. Asadi," Performance Investigation of New Combinational Load Shedding Schemes,"Joint International Conference on Power System Technology and IEEE Power India Conference, 2008. pp 1 – 8.
- [3] Dhiraj S. Bhojane, Saurabh R. Chaudhari,Eshant G. Rajgure, Prakash D. More "International Journal of Engineering Research and Applications (IJERA),"Vol. 2, Issue 1, Jan-Feb 2012, pp.747-753.
- [4] F. Capitanescu, B. Otomega, H. Lefebvre, V. Sermanson, T. Van Cutsem, "Decentralized tap changer blocking and load shedding against voltage instability Prospective tests on the RTE system, Electrical Power and Energy Systems,"Vol. 31, Issue 9, 2009, pp 570– 576.
- [5] Irfan quazi, Sachin Kumar gupta and Rajendra Prasad, "Prepaid Energy Meter based on AVR Microcontroller,"International Journal Of Engineering Research And Applications(IJERA) Volume1 1, Issue 4, pp.1879-1884.
- [6] J.J. Ford, H. Bevrani, G. Ledwich, "Adaptive load shedding and regional protection,"International Journal of Electrical Power & Energy Systems, Volume 31, Issue 10, November-December 2009, Pages 611618.
- [7] M. Gowsalya,M. BarathiSelvaraj, S. E. Murthy, K. Yadhiri, "Design and Analysis of a PLCC Based Home Automation System,"International Journal of Science Technology and Society Volume3 Issue2.
- [8] M.Sathishbabo, R.Chandru, K.Vanitha, "Microcontroller based consumer end energy consumption control from substation using plcc,"Third International Conference on Science Technology Engineering & Management (ICONSTEM) 2017.
- [9] Nitesh Kumar Jangir," PLCC with Sensors and Microcontroller Networking for Power Management,"International Journal of Computer and Electrical Engineering vol. 4, no. 2, pp. 223-226, 2012.
- [10] S. J. Huang, and C. C. Huang, "An adaptive load shedding method with time-based design for isolated power systems," International Journal of Electrical Power & Energy Systems, vol. 22, no. 1, January 2000, pp. 51-58.
- [11] T. Leibfried, "Online monitor keeps transformer in service," in IEEE Computer Applications in Power, vol. 11, July 1998, pp.36-42.