

Solar Powered Automatic Grass Cutter & Pesticide Spreading Robot

Prashant M. Chavan¹, Dhiraj V. Khurde², Sushant N. Adepwar³, Shubham S. Kute⁴, Dipannita R. Kundu⁵

¹Assistant Professor, Dept. of Electrical Engg., D.Y. Patil Institute of Engineering & Technology, Pune, India

^{2,3,4,5}PG Student, Dept. of Electrical Engg., D.Y. Patil Institute of Engineering & Technology, Pune, India

Abstract – Agriculture is demographically the broadest economic sector and plays a significant role in the overall economy of India. For the growth of Indian economy, mechanization is necessary. The main purpose of mechanization in agriculture is to improve the overall productivity and production.

The system control is done by the Arduino UNO R3. Automation is achieved by using sensors and Arduino UNO R3. Wheels and cutting operations are done using dc motors. DC battery is utilized for powering and standby mode operation of the system. The whole supply is provided through the battery and to charge the battery charger circuit is used to provide the charging for the battery.

Also the second application is that the spreading of pesticide here we used the water pump with spreading nozzle.

Key Words: Solar Panel, Sprayer, Grass Cutter, Wheel Control

1. INTRODUCTION

Agricultural sector is changing the socio-economic environment of the population due to liberalization and globalization. About 75% people are living in the rural area and are still dependent on agriculture. Agriculture has been the backbone of the Indian economy. Spraying of pesticides is an important task in agriculture for protecting the crops from insects. Farmers mainly use hand operated or fuel operated spray pump for this task. This conventional sprayer causes user fatigue due to excessive bulky and heavy construction. This motivated us to design and fabricate a model that is basically trolley based solar powered Grass Cutter, Pesticide Sprayer & Lighting System in a single unit. Due to use of Solar energy for operating pump & grass cutter, there will be elimination of engine of fuel operated spray pump & cutter by which there will be reduction in vibrations and noise.

The elimination of fuel will make our spraying system eco-friendly. Solar powered system can give less tariff or price in effective spraying, grass cutting & Lighting operation. Solar energy is absorbed by the solar panel which contains photovoltaic cells. The conversion of the solar energy into electrical energy is done by these cells. This converted energy utilizes to store the voltage in the DC battery which used to functions whole unit.

In this project we are using wireless technology for home automation. A home automation system is a means that allow users to control electric appliances of varying kind. The main aim of the project is to develop a system that will control of home appliances.

The basic requirement or need is android app because of we are overall home appliances through android app. Home automation systems develop to automatically achieve some activities performed frequently in daily life to obtain more comfortable and easier life environment. In home automation that can detect and identify you, automatically adjust the lighting to your predefined taste, open doors automatically, at night and switch them off in the morning, stream to you anywhere in the world via the internet. It is meant to save the electric power and human energy. IoT coverage is very wide and includes variety of objects like smart phones, tablets. Once all these devices are connected to each other, they enable more and more smart processes and services that support our basic needs.

2. LITERATURE SURVEY

Solar powered automatic lawn mower lawn buddy. This design contains a microcontroller, multiple sensors, and a solar charging system. Adding these elements together, they get their robotic lawn mower. Automatic grass cutting machine by using photovoltaic source and motor speed control. It is an automated system for the purpose of grass cutting. The Source is drive from the solar energy by using photovoltaic panels from the photovoltaic panel and store the dc voltage in a battery. Autonomous Pesticide Spraying Robot for use in a Greenhouse.

This paper presents an engineering solution to the current human health hazards involved in spraying potentially toxic chemicals in the contained space of a hot and steamy glasshouse. ARM- Based Pesticide Spraying Robot. The main use of robots in agriculture is for harvesting, Fruit picking, driverless tractor or sprayer are design to supersede human labor. Main aim is to avoid manual spraying of pesticides at actual farm. It will achieve by replacing human by a robot, through transmission of video of crop to central station. Development and Automation of Robot with Spraying Mechanism for Agricultural Applications. This is achieved by the design and construction of an autonomous mobile

robot for use in pest control and disease prevention applications in commercial Farm.

The effectiveness of this platform is shown by the ability to successfully navigate itself down rows of a Farm, spray the pesticides effectively while the farmer controls it from a far distance. And this pesticide spraying system efficiently covers the plants evenly with spray in the set dosages.

3. LITERATURE S NECESSITY FOR AN AUTOMATIC GRASS CUTTER, SPRAYER & LIGHTING UNIT

In order to spray the pesticides in farms, the people have to carry the pumps on their backs and pump it with their hands to pressurize it and they have bend down and cut the plants one after the other which puts a lot of strain and wears them out quickly. So, to reduce the human effort in rural areas we have developed a machine. The following challenges are overcome by this:

- There is a lack of mechanization in farming.
- Processes like spraying and grass cutting requires excess effort.
- More man power is required in agriculture field.
- More time consumption also leads to less productivity.
- To provide sufficient illumination in farm area.

4. METHODOLOGY

The methodology for this project is similar to the prototype analysis process. In this project we are fabricating a prototype of the solar powered grass cutter, Pesticides Sprayer & Lighting unit.

4.1 Proposed system block diagram

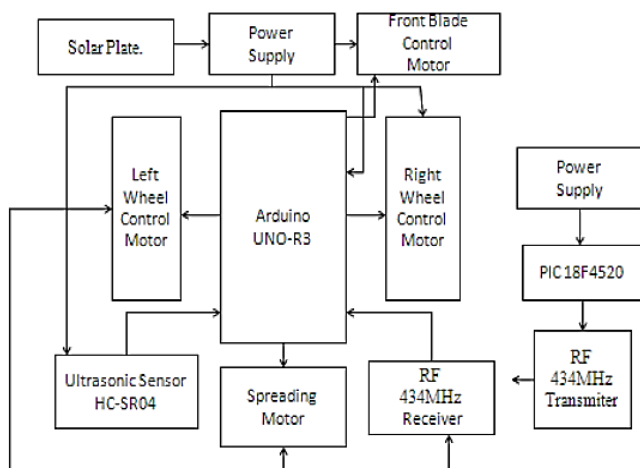

Fig -1: Proposed System Block Diagram

4.2 Working

In this project the main part is the Arduino UNO R3 which control the all assembly of project. The user is with the RF control remote , the user has to select that in which mode the system has to operate either it is in manual mode and the auto mode in manual mode the user has to decide that where to move robot but in auto mode the robot will decide that where it wants to go . By using ultrasonic sensor the robot will move. The blade of the robot is hand made design the motor used for the cutter is the brush less dc motor and it has the rpm of 35000 it operates on 12v dc supply.

The battery is source part for the project the battery is supplying the 12v dc for the motor and pump. The Charged on the solar plate once the battery is fully charged the robot will move properly. Also the second application is the pesticide spreading here we use the 12v dc operated pump with the 1.5m length pipe and the spreading nozzle is connected at the one end of the pipe. For supplying water to the and storing pesticide we use the water tank of 2 liter. RF control remote used here has the range of 300ft(100m). In this range the use has to give instruction to the robot. The RF uses the frequency of 434MHz and we use the encoder and decoder ic at the transmitter and receiver respectively. The ic are HT12E and HT12D. Also at transmitter the with encoder ic we use the another ic PIC181f4520 because the encoder ic is the 4 bit encoder but we require the greater than 4 bit control for that we use the PIC18f4520.

4.3 Solar Panels

A solar panel works by allowing photons, or particles of light, to knock electrons free from atoms, generating a flow of electricity. Solar panels actually comprise many, smaller units called photovoltaic cells. (Photovoltaic simply means they convert sunlight into electricity.) Many cells linked together make up a solar panel. Each photovoltaic cell is basically a sandwich made up of two slices of semi-conducting material, usually silicon — the same stuff used in microelectronics.



Fig -2: Solar Panel

To work, photovoltaic cells need to establish an electric field. Much like a magnetic field, which occurs due to

opposite poles, an electric field occurs when opposite charges are separated. To get this field, manufacturers "dope" silicon with other materials, giving each slice of the sandwich a positive or negative electrical charge.

4.4 Arduino Controller

The Arduino Uno R3 is a microcontroller board based on a removable, dual-inline-package (DIP) ATmega328 AVR microcontroller. It has 20 digital input/output pins (of which 6 can be used as PWM outputs and 6 can be used as analog inputs). Programs can be loaded on to it from the easy-to-use Arduino computer program. The Arduino has an extensive support community, which makes it a very easy way to get started working with embedded electronics. The R3 is the third, and latest, revision of the Arduino Uno.



Fig -3: Arduino Controller

The Arduino Uno is a microcontroller board based on the ATmega328. It has 20 digital input/output pins (of which 6 can be used as PWM outputs and 6 can be used as analog inputs), a 16 MHz resonator, a USB connection, a power jack, an in-circuit system programming (ICSP) header, and a reset button. It contains everything needed to support the microcontroller; simply connect it to a computer with a USB cable or power it with an AC-to-DC adapter or battery to get started.

4.5 DC Motor

An electric motor is an electrical machine which converts electrical energy into mechanical energy. The basic working principle of a DC motor: "whenever a current carrying conductor is placed in a magnetic field, it experiences a mechanical force". The direction of this force is given by Fleming's left-hand rule and its magnitude is given by $F = BIL$. Where, B = magnetic flux density, I = current and L = length of the conductor within the magnetic field.



Fig -4: DC Motor

Fleming's left hand rule: If we stretch the first finger, second finger and thumb of our left hand to be perpendicular to each other, and the direction of magnetic field is represented by the first finger, direction of the current is represented by the second finger, then the thumb represents direction of the force experienced by the current carrying conductor.

4.6 Ultrasonic Sensor

An ultrasonic sensor is an instrument that measures the distance to an object using ultrasonic sound waves. An ultrasonic sensor uses a transducer to send and receive ultrasonic pulses that relay back information about an object's proximity. High-frequency sound waves reflect from boundaries to produce distinct echo patterns.



Fig -5: Ultrasonic Sensor

Ultrasonic sensors work by sending out a sound wave at a frequency above the range of human hearing. The transducer of the sensor acts as a microphone to receive and send the ultrasonic sound. Our ultrasonic sensors, like many others, use a single transducer to send a pulse and to receive the echo. The sensor determines the distance to a target by measuring time lapses between the sending and receiving of the ultrasonic pulse.

4.7 RF 434MHz Trance-receiver

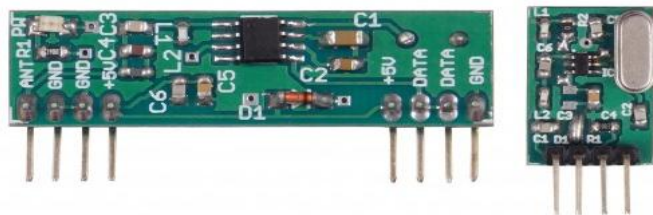

Fig -6: RF 434MHz Trance-receiver

Features of RF module :-

Operating Frequency -434MHz

Operating Range-100m(300ft)

Operating Voltage-5V

4.8 Water Pump



Fig -7: Water Pump

Operating voltage 12v

Current-0.1A-0.5A

Lift-130cm

Flow Rte-300L/H

4.9 Flow Chart

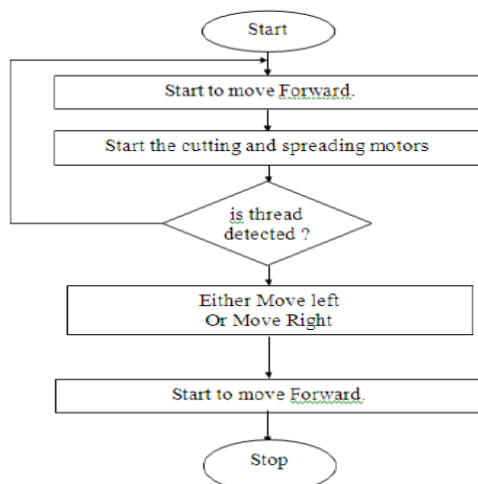

Fig -8: Flow Chart

5. CONCLUSIONS

By doing this project we conclude that ,we can reduce the human efforts and this will be helpful for farmer . As it is operated on solar energy so the it is best application that dose not affects on environment.

This project work has presented progress towards achieving a future precision autonomous farming system. This system is designed to help farmers in reducing their time and energy spent for pesticide spraying and weed cutting. This system can be operated on +12V rechargeable battery. This system will reduce labor problem in future. So, this system will be the best replacement for currently used systems like hand sprayers and tiller mounted sprayers.

REFERENCES

- [1] Laukik P. Raut, Smit B. Jaiswal, Nitin Y. Mohite. (2013, Nov.) "Design, development and fabrication of agricultural pesticides sprayer with weeder", International Journal of Applied Research and studies, pp. 1-8.
- [2] Prashant M. Chavan, Gayatri P. Chavan, "Interfacing of Wind Energy to Grid using Static Compensator and Load Reactive Power Compensation", Information Communication Engineering and Technology (ICICET) 2018 International Conference on, pp. 1-4, 2018.
- [3] P. M. Chavan, Girish R. Walake, "Interfacing of Renewable Energy Source to Grid Using STATCOM to Improve the Power Quality", international Journal of Engineering Technology Management and Applied Sciences, vol. 3, no. 3, pp. 2349-4476, March 2015.
- [4] Prashant M. Chavan, Girish R. Walke, "Using STATCOM interfacing of renewable energy source to grid and power quality improvement", 2015 International Conference on Energy Systems and Applications, 30 Oct.-1 Nov. 2015, Pune, India.
- [5] Prashant M. Chavan, Gayatri P. Chavan, "Interfacing of hybrid power system to grid using STATCOM & power quality improvement", Information, Communication, Instrumentation and Control (ICICIC), 2017 International Conference, 17-19 Aug. 2017, Indore, India.
- [6] Rohit Kumar Single, Abhishek Kumar, Vikrant Kumar, Abhishek Kumar, Prashant M. Chavan, "Single Stage Single Phase Reconfigurable Inverter Topology", International Research Journal of Engineering and Technology, Volume 6 Issue 5, May 2019.
- [7] Safalta G. Pimpale, Ajay B. Patil, Mahesh P. Rane, Parshant M. Chavan, "Fingerprint Sensor based Controlling and Operation of Power Supply", International Journal of Research in Engineering,

Science and Management, Volume 1, Issue 12, December 2018.

- [8] Prashant M. Chavan, Girish R. Walke, "Power Quality Improvement and Interfacing of Wind Energy Source", International Journal of Engineering Sciences & Research Technology, vol. 4, no. 6, 2015.
- [9] Prashant M Chavan, Dhiraj V Khurde, Sushant N Adepwar, Shubham S Kute, Dipannita R Kundu, "Solar Powered Electric Grass Cutter, Pesticides Sprayer and Lighting Unit", International Journal of Research in Engineering, Science and Management, Volume 2, Issue 11, November-2019.
- [10] Mr Prashant M Chavan, Mr Girish R Walke, "Power Quality Improvement And Interfacing of Wind Energy Source", International Journal of Engineering Sciences & Research Technology, Volume 4, Issue 6, June 2015.